

CS61C : Machine Structures

Lecture #26: Disks & Networks



2005-08-04

Andy Carle



Outline

- Buses
- Networks
- Disks



Buses in a PC: connect a few devices (2002)

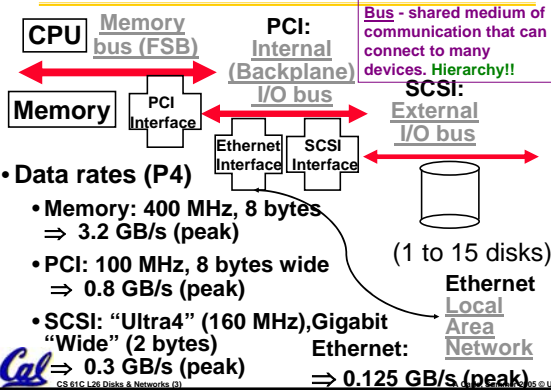

Main components of Intel Chipset: Pentium II/III

- Northbridge:
 - Handles memory
 - Graphics
- Southbridge: I/O
 - PCI bus
 - Disk controllers
 - USB controllers
 - Audio
 - Serial I/O
 - Interrupt controller
 - Timers

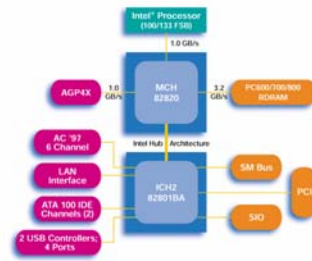

A Three-Bus System (+ backside cache)

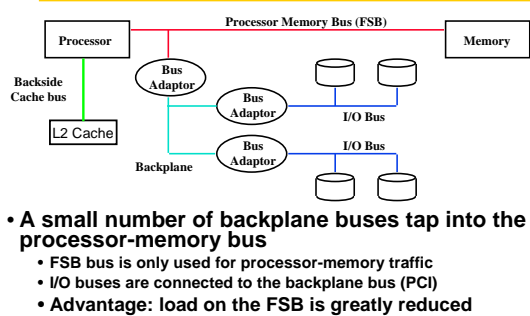

What is DMA (Direct Memory Access)?

- Typical I/O devices must transfer large amounts of data to memory of processor:
 - Disk must transfer complete block
 - Large packets from network
 - Regions of frame buffer

- DMA gives external device ability to access memory directly:
 - much lower overhead than having processor request one word at a time.

- Issue: Cache coherence:

- What if I/O devices write data that is currently in processor Cache?
 - The processor may never see new data!
- Solutions:
 - Flush cache on every I/O operation (expensive)
 - Have hardware invalidate cache lines ("Coherence" cache misses?)



Outline

- Buses
- Networks
- Disks



CS 61C L26 Disks & Networks (7)

A Carls, Summer 2005 © UCB

Why Networks?

- Originally sharing I/O devices between computers
(e.g., printers)
- Then Communicating between computers
(e.g, file transfer protocol)
- Then Communicating between people
(e.g., email)
- Then Communicating between networks of computers
⇒ p2p File sharing, WWW, ...



CS 61C L26 Disks & Networks (8)

A Carls, Summer 2005 © UCB

How Big is the Network (1999)?

- ~30 Computers in 271 Soda
- ~400 in inst.cs.berkeley.edu
- ~4,000 in eecs&cs .berkeley.edu
- ~50,000 in berkeley.edu
- ~5,000,000 in .edu
- ~46,000,000 in US
(.com .net .edu .mil .us .org)
- ~56,000,000 in the world



Source: Internet Software Consortium

CS 61C L26 Disks & Networks (9)

A Carls, Summer 2005 © UCB

Growth Rates

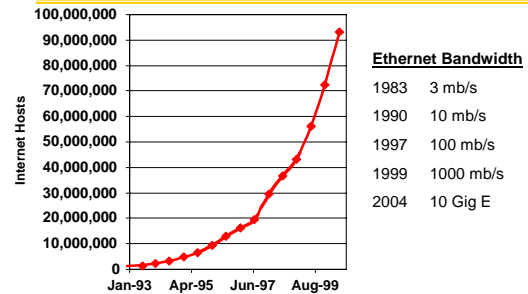

"Source: Internet Software Consortium (<http://www.isc.org/>)".



CS 61C L26 Disks & Networks (10)

A Carls, Summer 2005 © UCB

What makes networks work?

- links connecting switches to each other and to computers or devices

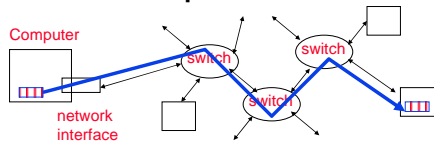

- ability to **name** the components and to **route** packets of information - messages - from a source to a destination
- Layering, protocols, and encapsulation as means of **abstraction** (61C big idea)



CS 61C L26 Disks & Networks (11)

A Carls, Summer 2005 © UCB

Typical Types of Networks

- **Local Area Network (Ethernet)**
 - Inside a building: Up to 1 km
 - (peak) Data Rate: 10 Mbits/sec, 100 Mbits/sec, 10Gbits/sec (1.25, 12.5, 1250 MBytes/s)
 - Run, installed by network administrators
- **Wide Area Network**
 - Across a continent (10km to 10000 km)
 - (peak) Data Rate: 1.5 Mb/s to >10000 Mb/s
 - Run, installed by telecommunications companies (Sprint, UUNet[MCI], AT&T)



CS 61C L26 Disks & Networks (12)

A Carls, Summer 2005 © UCB

Wireless Networks

ABCs of Networks: 2 Computers

- **Starting Point:** Send bits between 2 computers

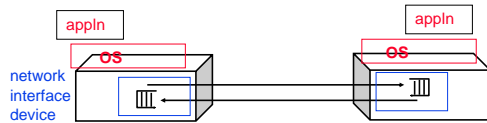

- Queue (First In First Out) on each end
- Can send both ways (“**Full Duplex**”)
- Information sent called a “**message**”
 - Note: Messages also called **packets**



CS 61C L26 Disks & Networks (13)

A Carls, Summer 2005 © UCB

A Simple Example: 2 Computers

- **What is Message Format?**

- Similar idea to Instruction Format
- Fixed size? Number bits?

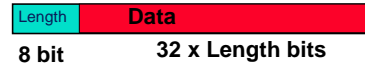

- **Header(Trailer):** information to deliver message
- **Payload:** data in message
- What can be in the data?
 - anything that you can represent as bits
 - values, chars, commands, addresses...



CS 61C L26 Disks & Networks (14)

A Carls, Summer 2005 © UCB

Questions About Simple Example

- What if more than 2 computers want to communicate?
 - Need computer “**address field**” in packet to know which computer it (destination), and to which computer it came from for reply (source) [just like envelopes!]

Dest. Source Len

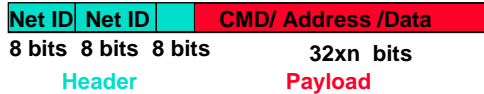

CS 61C L26 Disks & Networks (15)

A Carls, Summer 2005 © UCB

ABCs: many computers

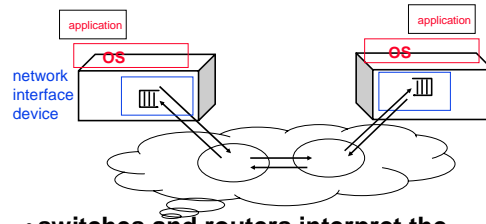

- switches and routers interpret the header in order to deliver the packet
- source encodes and destination decodes content of the payload



CS 61C L26 Disks & Networks (16)

A Carls, Summer 2005 © UCB

Questions About Simple Example

- What if message is garbled in transit?
- Add redundant information that is checked when message arrives to be sure it is OK
- 8-bit sum of other bytes: called “**Check sum**”; upon arrival compare check sum to sum of rest of information in message

Checksum



Math 55 talks about what a Check sum is...

CS 61C L26 Disks & Networks (17)

A Carls, Summer 2005 © UCB

Questions About Simple Example

- What if message never arrives?
- Receiver tells sender when it arrives (ack) [ala registered mail], sender retries if waits too long
- Don't discard message until get “**ACK**” (for **ACK**nowledgment); Also, if check sum fails, don't send **ACK**

Checksum



CS 61C L26 Disks & Networks (18)

A Carls, Summer 2005 © UCB

Observations About Simple Example

- Simple questions such as those above lead to more complex procedures to send/receive message and more complex message formats
- **Protocol**: algorithm for properly sending and receiving messages (packets)



Software Protocol to Send and Receive

- **SW Send steps**
 - 1: Application copies data to OS buffer
 - 2: OS calculates checksum, starts timer
 - 3: OS sends data to network interface HW and says start
- **SW Receive steps**
 - 3: OS copies data from network interface HW to OS buffer
 - 2: OS calculates checksum, if OK, send ACK; if not, **delete message** (sender resends when timer expires)
 - 1: If OK, OS copies data to user address space, & signals application to continue



Protocol for Networks of Networks?

- **Internetworking**: allows computers on independent and incompatible networks to communicate reliably and efficiently;
 - Enabling technologies: SW standards that allow reliable communications without reliable networks
 - Hierarchy of SW layers, giving each layer responsibility for portion of overall communications task, called **protocol families** or **protocol suites**
- **Abstraction** to cope with **complexity of communication** vs. Abstraction for complexity of **computation**



Protocol Family Concept

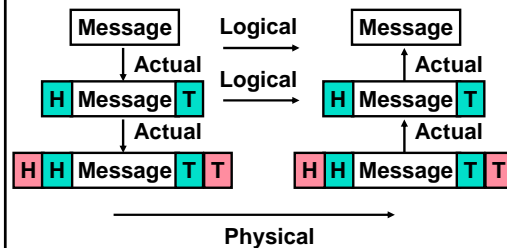

Protocol Family Concept

- Key to **protocol families** is that communication occurs **logically** at the same level of the protocol, called **peer-to-peer**...
- ...but is **implemented via services at the next lower level**
- **Encapsulation**: carry higher level information within lower level "envelope"
- **Fragmentation**: break packet into multiple smaller packets and reassemble



Protocol for Network of Networks

- **Transmission Control Protocol/Internet Protocol (TCP/IP)**
 - This protocol family is the **basis of the Internet**, a WAN protocol
 - IP makes best effort to deliver
 - TCP guarantees delivery
 - TCP/IP so popular it is used even when communicating locally: even across homogeneous LAN



TCP/IP packet, Ethernet packet, protocols

- Application sends message
- TCP breaks into 64KB segments, adds 20B header
- IP adds 20B header, sends to network
- If Ethernet, broken into 1500B packets with headers, trailers (24B)
- All Headers, trailers have length field, destination,

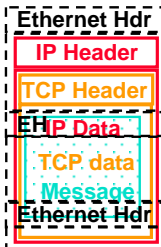

Overhead vs. Bandwidth

- Networks are typically advertised using peak bandwidth of network link: e.g., 100 Mbits/sec Ethernet (“100 base T”)
- Software overhead to put message into network or get message out of network often limits useful bandwidth
- Assume overhead to send and receive = 320 microseconds (μ s), want to send 1000 Bytes over “100 Mbit/s” Ethernet
 - Network transmission time: $1000B \times 8b/B / 100Mb/s = 8000b / (100b/\mu s) = 80 \mu s$
 - Effective bandwidth: $8000b / (320+80)\mu s = 20 Mb/s$



Shared vs. Switched Based Networks

- Shared Media vs. Switched: in switched, pairs (“point-to-point” connections) communicate at same time; shared 1 at a time
- Aggregate bandwidth (BW) in switched network is many times shared:
 - point-to-point faster since no arbitration, simpler interface

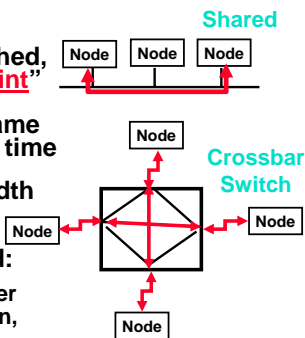

Network Summary

- Protocol suites allow heterogeneous networking
 - Another form of principle of abstraction
 - Protocols \Rightarrow operation in presence of failures
 - Standardization key for LAN, WAN
- Integrated circuit (“Moore’s Law”) revolutionizing network switches as well as processors
 - Switch just a specialized computer
- Trend from shared to switched networks to get faster links and scalable bandwidth



Outline

- Buses
- Networks
- Disks



Magnetic Disks

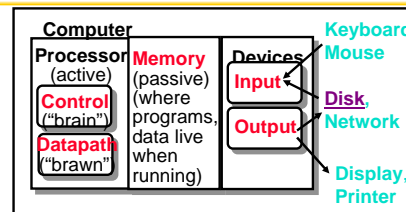

- Purpose:
 - Long-term, nonvolatile, inexpensive storage for files
 - Large, inexpensive, slow level in the memory hierarchy (discuss later)



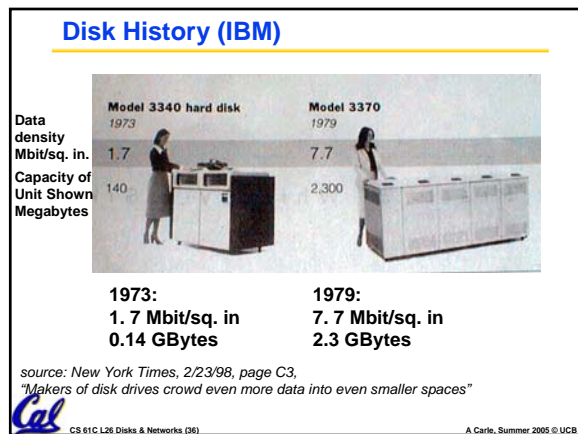
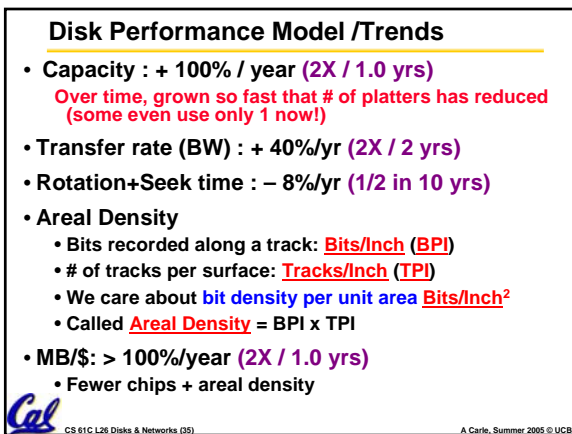
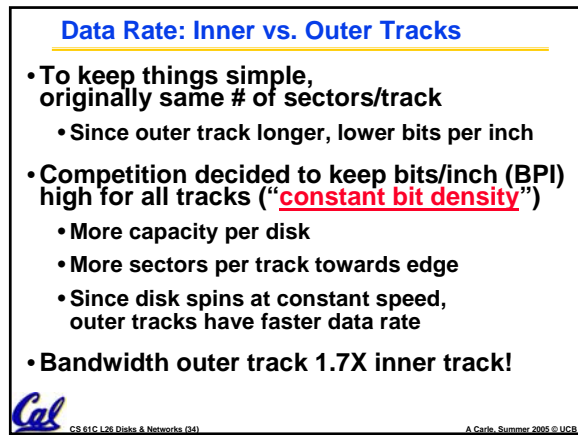
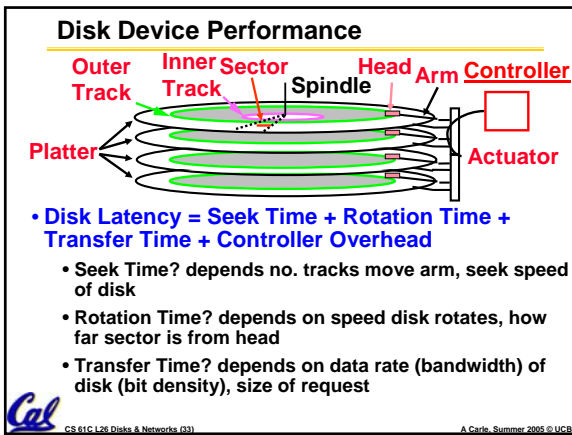
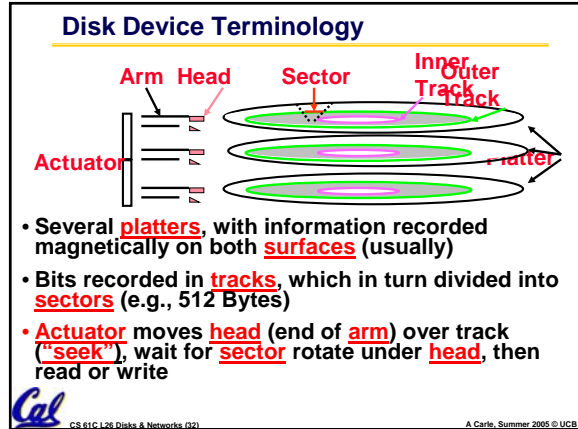
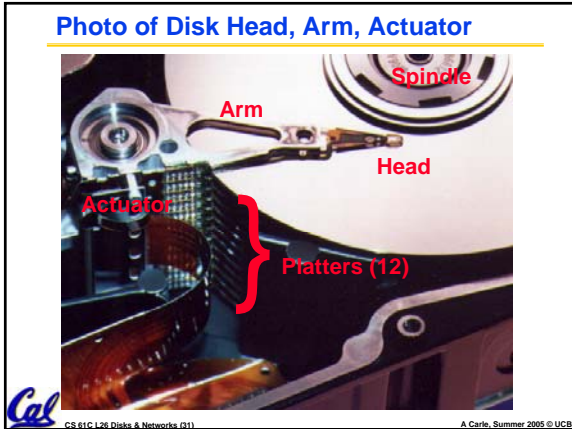

Disk History



1989: 63 Mbit/sq. in 60 GBytes
 1997: 1450 Mbit/sq. in 2.3 GBytes
 1997: 3090 Mbit/sq. in 8.1 GBytes

source: New York Times, 2/23/98, page C3,
 "Makers of disk drives crowd even more data into even smaller spaces"



CS 61C L26 Disks & Networks (37)

A Carlo, Summer 2005 © UCB

Modern Disks: Barracuda 7200.7 (2004)

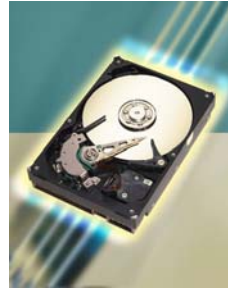

- 200 GB, 3.5-inch disk
- 7200 RPM; Serial ATA
- 2 platters, 4 surfaces
- 8 watts (idle)
- 8.5 ms avg. seek
- 32 to 58 MB/s Xfer rate
- \$125 = **\$0.625 / GB**

source: www.seagate.com;



CS 61C L26 Disks & Networks (38)

A Carlo, Summer 2005 © UCB

Modern Disks: Mini Disks

- 2004 Toshiba Minidrive:
 - 2.1" x 3.1" x 0.3"
 - 40 GB, 4200 RPM, 31 MB/s, 12 ms seek
 - 20GB/inch³ !!
 - Mp3 Players



CS 61C L26 Disks & Networks (39)

A Carlo, Summer 2005 © UCB

Modern Disks: 1 inch disk drive!

- 2004 Hitachi Microdrive:
 - 1.7" x 1.4" x 0.2"
 - 4 GB, 3600 RPM, 4-7 MB/s, 12 ms seek
 - 8.4 GB/inch³
 - Digital cameras, PalmPC
- 2006 MicroDrive?
 - 16 GB, 10 MB/s!
 - Assuming past trends continue



CS 61C L26 Disks & Networks (40)

A Carlo, Summer 2005 © UCB

Modern Disks: << 1 inch disk drive!

- Not magnetic but ...
- 1gig Secure digital
 - Solid State NAND Flash
 - 1.2" x 0.9" x 0.08" (!!)
 - 11.6 GB/inch³



CS 61C L26 Disks & Networks (41)

A Carlo, Summer 2005 © UCB

Magnetic Disk Summary

- Magnetic Disks continue rapid advance: 60%/yr capacity, 40%/yr bandwidth, slow on seek, rotation improvements, MB/\$ improving 100%/yr?
 - Designs to fit high volume form factor
- RAID
 - Higher performance with more disk arms per \$
 - Adds option for small # of extra disks
 - Today RAID is > \$27 billion dollar industry, 80% nonPC disks sold in RAIDs; **started at Cal**



CS 61C L26 Disks & Networks (42)

A Carlo, Summer 2005 © UCB