

1. Fundamental Quantities in Electronics

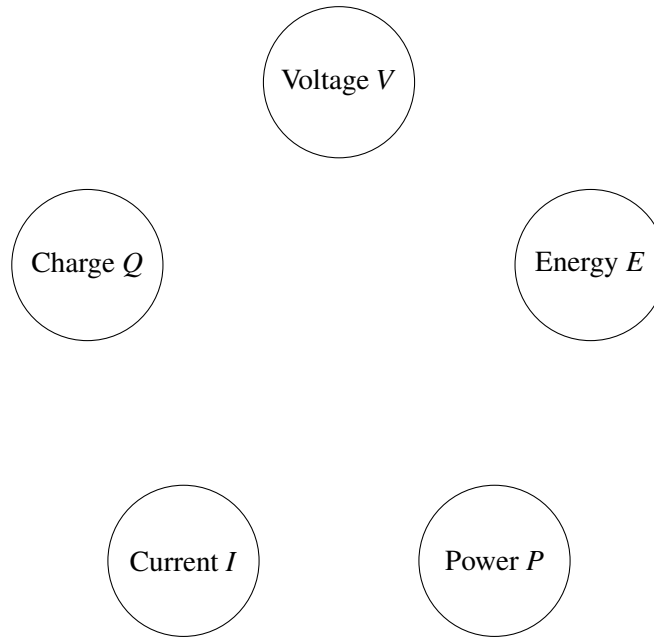

- (a) Write down three things that you associate with each bubble.
- (b) Draw lines between intrinsically connected quantities.
- (c) For each line that you drew, write an equation describing the relationship.

2. Current Divider

In lecture, we showed that for the circuit shown to the left, we can find the voltage across the resistor  $R_2$  using a simple formula:

$$V_{R_2} = \frac{R_2}{R_1 + R_2} V_s$$

Try to derive a similar formula for the circuit shown below to the right, relating the current  $I_{R_2}$  through  $R_2$  to the current through the current source  $I_s$ .

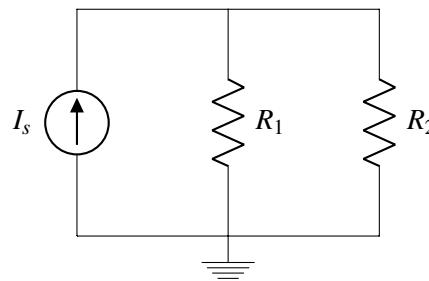
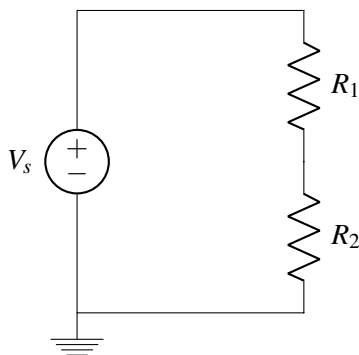

### 3. Bio-Molecule Detector

One application for electronics that has gained a lot of attention over the past several years is in so-called “bio-molecule” detection. The idea is to build a system that detects the presence of specific molecules and/or cells (e.g. specific viruses, proteins, etc.) in a biological sample; if this detection can be performed automatically and using relatively low-cost components, it can have a dramatic impact on a number of areas such as medical diagnosis, drug development, DNA sequencing, etc.

In this problem, we’ll look at how some of the techniques we learned about in the touchscreen module can be applied to realize a hypothetical bio-molecule detector. (Real bio-molecule detection systems involve quite a bit more complexity than what we’ll include here, but in many designs the same basic principles apply.)

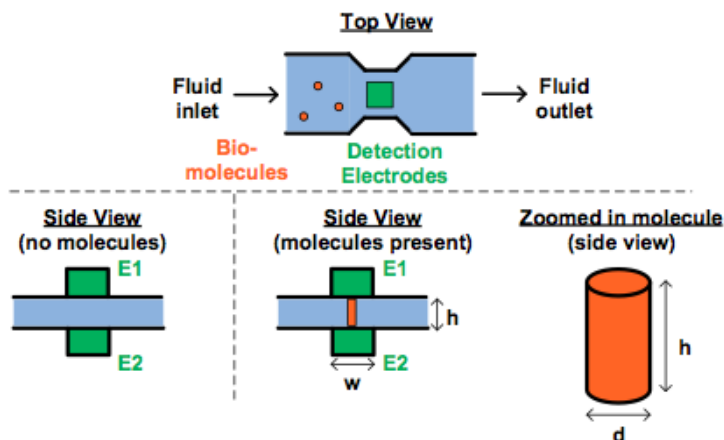

Figure 1: Bio-molecule detector.

As shown in Figure 1, the detector works by flowing a liquid that may or may not contain the biomolecules through a region in the device that has electrodes on the top and bottom of the liquid channel. The electrodes (E1/E2 in Figure 1) are chemically “functionalized” (using e.g. some appropriately designed antibodies), so that if the specific bio-molecule of interest is present in the fluid sample, one or more of the molecules will get physically trapped between the two electrodes (bottom right of Figure 1). After all of the fluid has been cleared out of the device (i.e., so that if there are bio-molecules present, there is only air in between the two electrodes E1/E2), we can then figure out whether or not one or more bio-molecules were trapped by measuring the resistance between the two electrodes.

- Let’s first assume that we want to detect the presence of a bio-molecule by measuring resistance. If no bio-molecule is present, what should be the resistance between E1/E2? As shown in Figure 1, if each bio-molecule is a cylinder with diameter  $d = 10\text{nm}$ , height  $h = 100\text{nm}$ , and has a resistivity  $\rho = 100\mu\Omega\text{m}$ , what would be the resistance between E1 and E2 if only a single bio-molecule has been trapped? Note that you can assume that the trapped molecule is exactly vertically oriented when it is trapped – i.e., the top and bottom faces of the molecule are both aligned with surfaces of the electrodes.
- Using the same numbers for  $d$ ,  $h$ , and  $\rho$  as part (a), as a function of the number of trapped bio-molecules  $N_{\text{molecules}}$ , what is the resistance between E1 and E2? (Note that you can assume that  $N_{\text{molecules}}$  is small enough that all of the molecules fit within the electrode area and that all of the molecules are still trapped in an exactly vertical orientation.)
- Given your answers to parts (a) and (b), design a circuit that will output a voltage greater than  $2.5\text{V}$  if more than 5 molecules are trapped.