

15.1 Voltage Divider Circuit Review

Before modeling the 2D touchscreen, let's review the most important concept that has enabled 1D touch-screen modeling: voltage divider circuit.

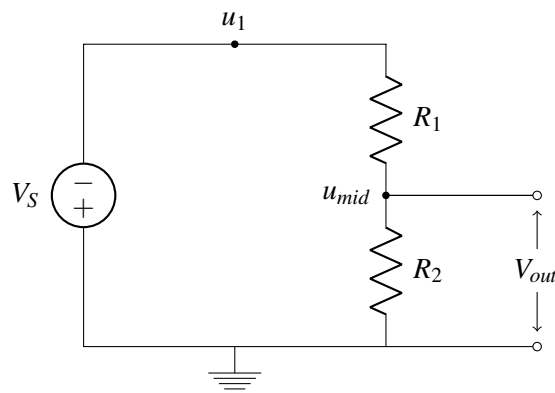

$$V_{out} = \frac{R_2}{R_1 + R_2} \times V_s. \quad (1)$$

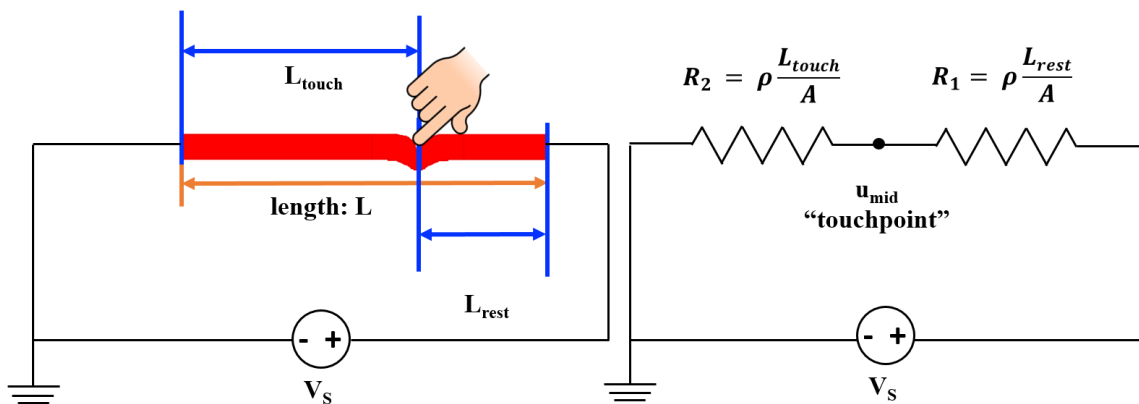

By using a voltage divider circuit, we can map u_{mid} to L_{touch} . A relationship between u_{mid} and L_{touch} exists such that:

$$u_{mid} = \frac{R_2}{R_1 + R_2} \times V_s = \frac{L_{touch}}{L} \times V_s. \quad (2)$$

15.2 EE16A Physics Revisited

Before we dive into the modeling of 2D resistive touchscreen, let's review the I-V characteristics for some basic circuit elements.

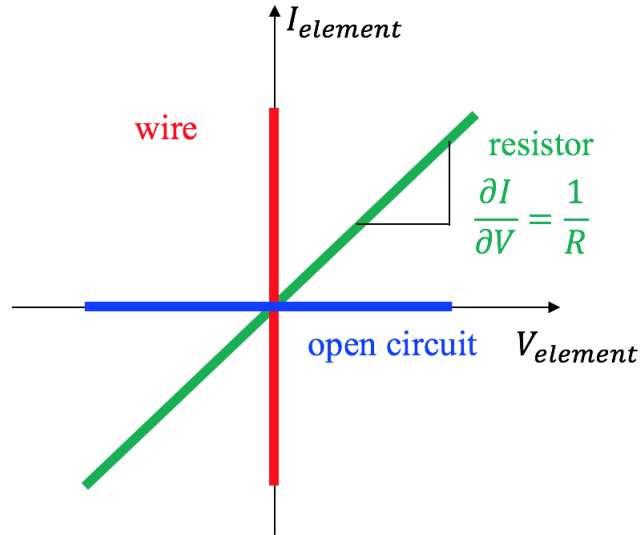

From the I-V plots, although a resistor, a wire and an open circuit can behave quite differently, their behaviors are exactly the same at $(0, 0)$. This means that at $(0, 0)$, these three circuit elements can be replaced by one another and the same behavior ($I = 0, V = 0$) is still expected.

15.3 An Interesting Circuit

Now, out of intellectual curiosity, let's draw an interesting circuit and soon you will soon see the relationship between this circuit and the voltage divider circuit.

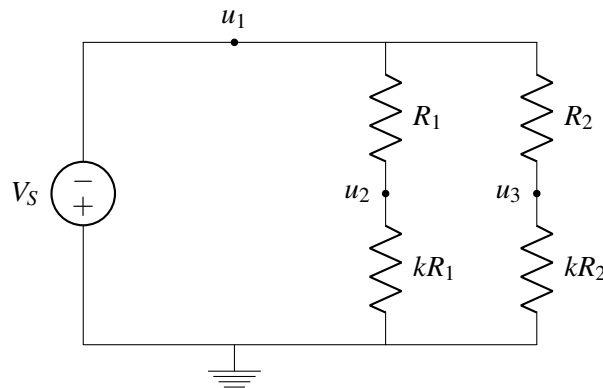

Given the knowledge we have for the voltage divider circuit, we actually do not have to apply the circuit analysis algorithm to this interesting circuit to derive u_1, u_2, u_3 .

Because $u_1 = V_s$, the resistors R_1, kR_1 see exactly the same voltage drop $(u_1 - 0) = V_s$ as what R_1, R_2 see in the voltage divider circuit. So R_1, kR_1 are connected just like the two resistors in the voltage divider circuit. Therefore, we have

$$u_2 = \frac{kR_1}{R_1 + kR_1} V_s = \frac{k}{1+k} V_s. \quad (3)$$

Similarly, R_2, kR_2 are also connected just like R_1, R_2 in the voltage divider circuit, we can write down:

$$u_3 = \frac{kR_2}{R_2 + kR_2} V_s = \frac{k}{1+k} V_s. \quad (4)$$

So now we have: $u_2 = u_3 = \frac{k}{1+k} V_s$.

Now, let's add another resistor R_3 to the circuit.

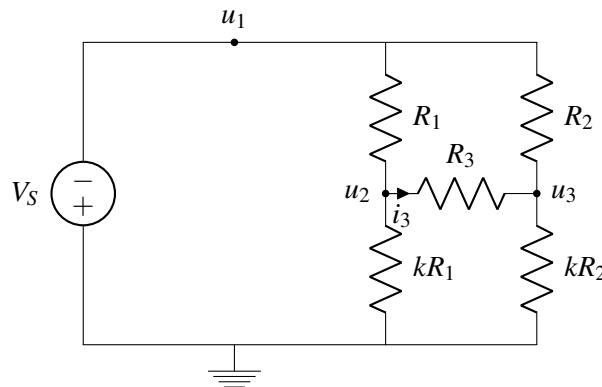

Despite that we have added R_3 to our circuit. We actually already know what u_2, u_3 should be. Let's now make a bold assumption that adding R_3 will not affect circuit operation, therefore u_2 and u_3 will remain the same.

After making this bold guess, let's analyze this new circuit to see if we can validate this guess.

Let's first analyze the current flow through R_3 .

$$R_3 \times i_3 = u_2 - u_3 \quad (5)$$

Under the assumption that $u_2 = u_3$, i_3 and the voltage drop across R_3 are both zero. So R_3 is at the special $(0, 0)$ point on the I-V plot, we can then replace R_3 with an open circuit or a wire without affecting circuit operation. We choose to replace R_3 with an open circuit:

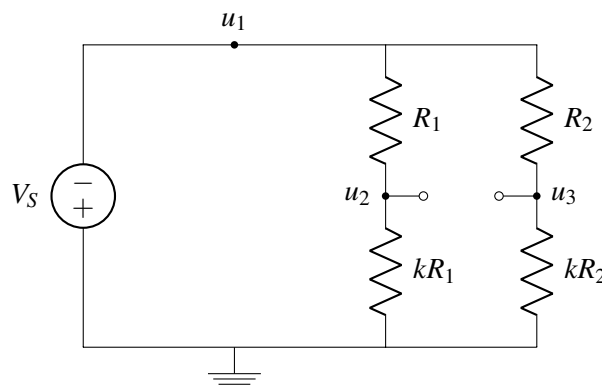

Now, the interesting circuit becomes the same as before the addition of R_3 . Our bold assumption that R_3 will not affect circuit operation is indeed correct. By replacing R_3 with an open circuit after figuring out R_3 is at $(0, 0)$ on the I-V plot, we can write down u_2, u_3 directly:

$$u_2 = u_3 = \frac{k}{1+k} V_S. \quad (6)$$

Let's contemplate why we can replace R_3 with an open circuit. If we replace R_1, kR_1, R_2, kR_2 in the interesting circuit with some arbitrary resistors, can we still replace R_3 with an open circuit? No, it is because we have set up R_1, kR_1, R_2, kR_2 in a way so that $u_2 = u_3$, which has made the voltage drop and current flow for R_3 both be zero, we can make such simplification. We can make such replacements only if the resistor is at $(0, 0)$ on the I-V plot without affecting circuit operation.

15.4 2D Resistive Touchscreen

Now, let's analyze the physical structure of a 2D touchscreen, it consists of a top red plate and a bottom black plate. When a finger touches the screen, the top red plate get in contact with the bottom black plate at the touch point.

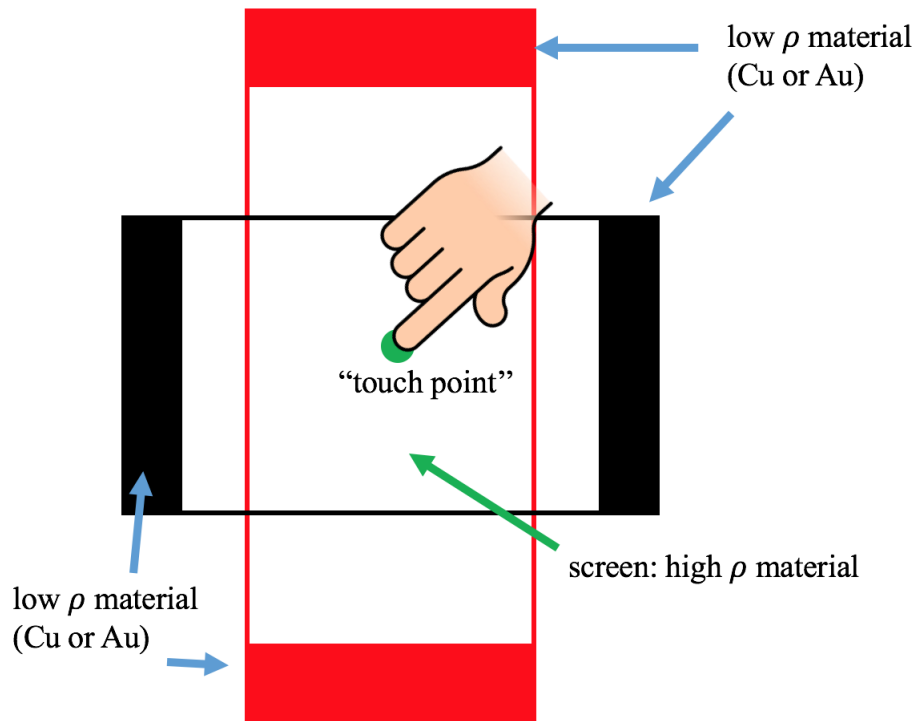

The left and right ends of the top red plate as well as the left and right ends of the bottom black plate are made of materials that have very low resistivities ρ , we can treat them as ideal wires ($\rho = 0$). The materials of the transparent screen that we touch in the middle have much higher resistivity.

In a 2D touchscreen, we want to figure out the vertical position and the horizontal position of the touch point: $L_{\text{touch, vertical}}, L_{\text{touch, horizontal}}$.

Let's first analyze the physical structure of the top red plate. We can divide the top red plate into three

segments (of equal width) represented by resistors, which are connected in between by horizontal resistors R_{h1} , R_{h2} .

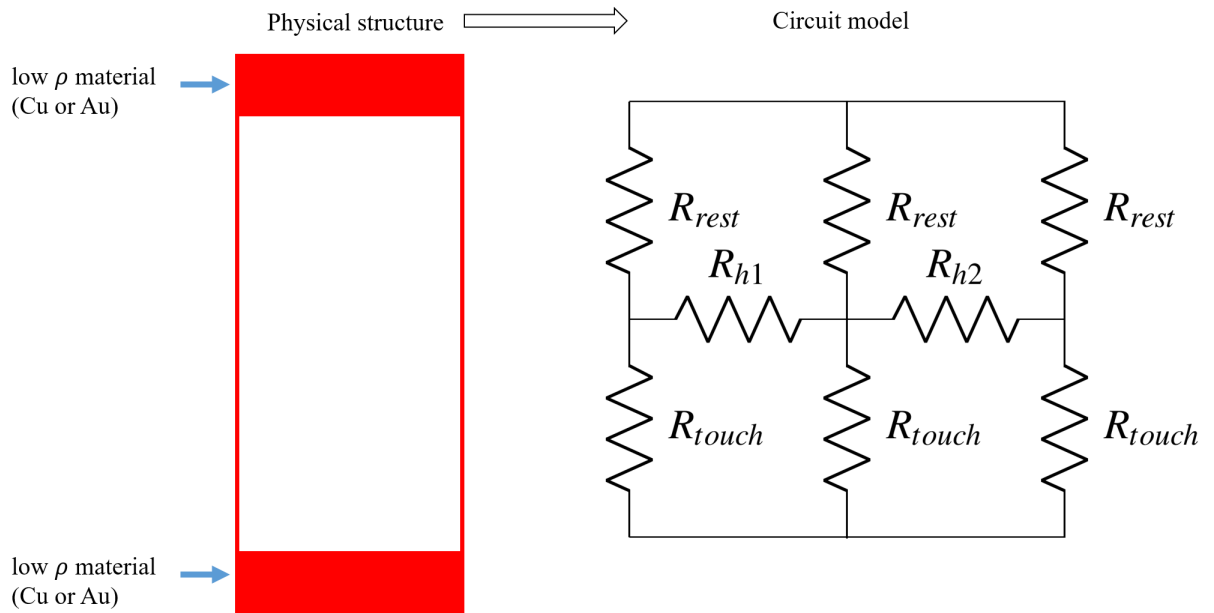

Now, let's connect a voltage supply V_s to the top and bottom ends of the top red plate:

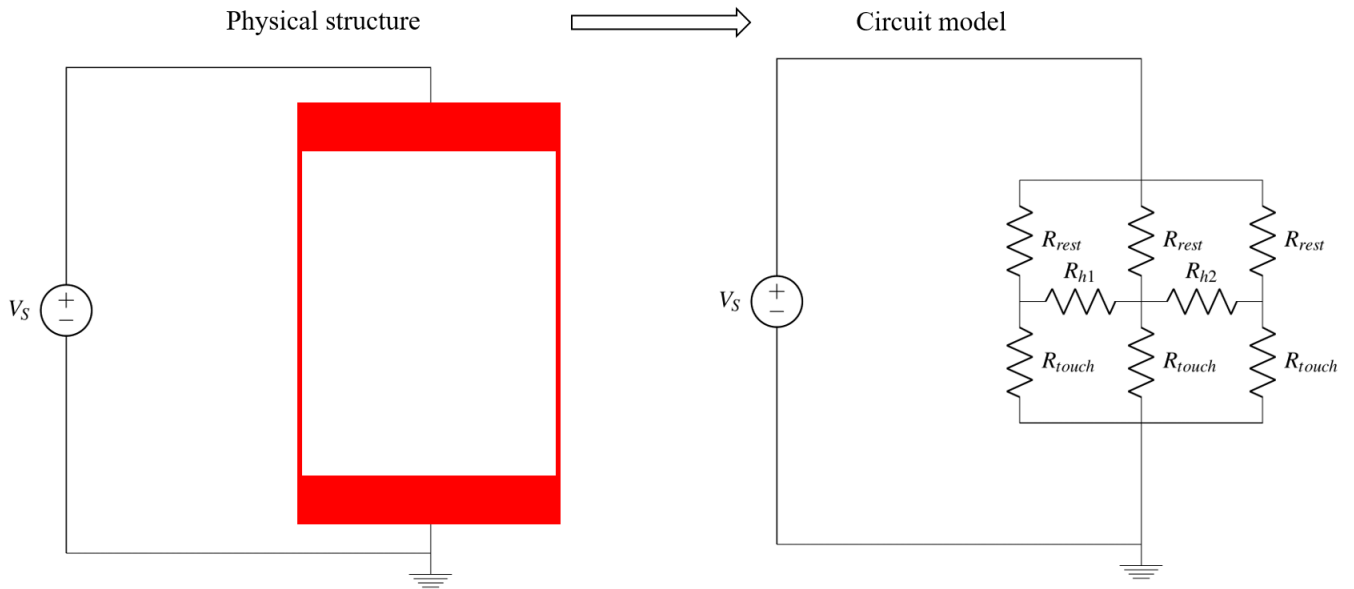

Let's analyze the circuit we just built with the top red plate and a voltage supply V_s :

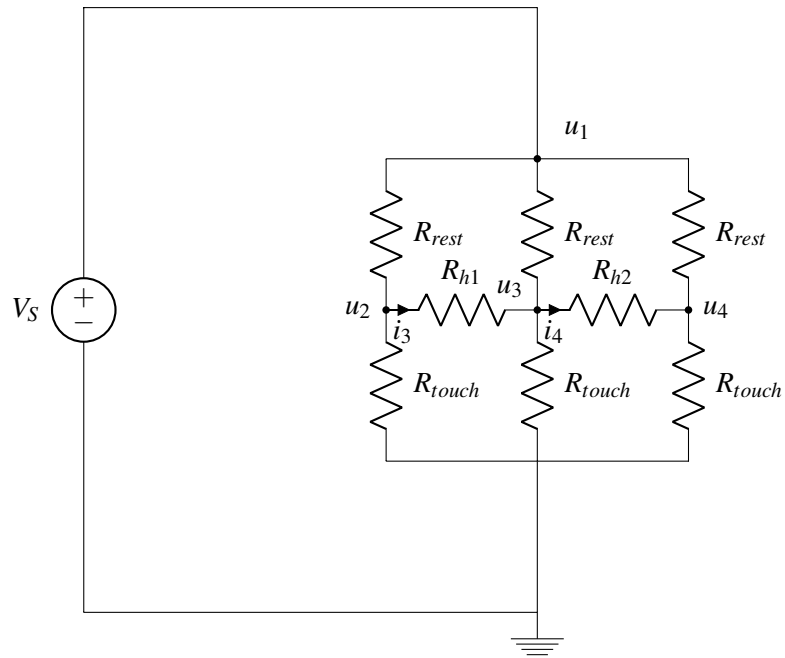

Since R_{rest} and R_{touch} are the same for each segment, we can replace horizontal resistors R_{h1}, R_{h2} like we did when analyzing the interesting circuit because $u_2 = u_3, u_3 = u_4$.

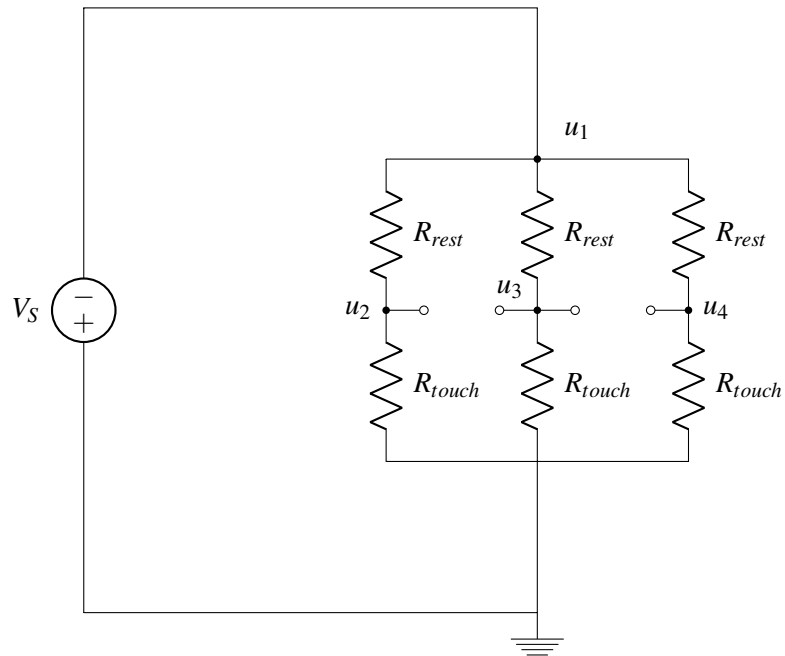

After replacing horizontal resistors with open circuit, we can use a voltmeter and measure u_3 , which is:

$$u_3 = \frac{R_{touch}}{R_{rest} + R_{touch}} \times V_S. \quad (7)$$

Given $R_{touch} = \rho \frac{L_{touch}}{A}$, $R_{rest} = \rho \frac{L_{rest}}{A}$, u_3 can be further simplified:

$$u_3 = \frac{L_{touch}}{L} \times V_s, L_{touch} = L_{touch, vertical} \quad (8)$$

u_3 is mapped to the vertical position touched in the same way as the 1D touchscreen. When measuring the vertical position touched ($L_{touch, vertical}$), the bottom black plate connects to a voltmeter and measures u_3 . Although we have represented the top red plate by three segments of equal width in the circuit model we built, the value of u_3 will remain the same if we choose to represent the top red plate by infinite number of segments.

Recall that to solve the 2-D touchscreen problem, we need to figure out not only $L_{touch, vertical}$ but also $L_{touch, horizontal}$. If we supply voltage source V_s to the bottom black plate, and connect the top red plate to a voltmeter, we can measure the horizontal position touched.

Similarly, we choose to represent the bottom black plate by three segments of equal width which are connected in between by vertical resistors R_{v1}, R_{v2} , and connect a voltage supply V_s to the left and right ends of the bottom black plate.

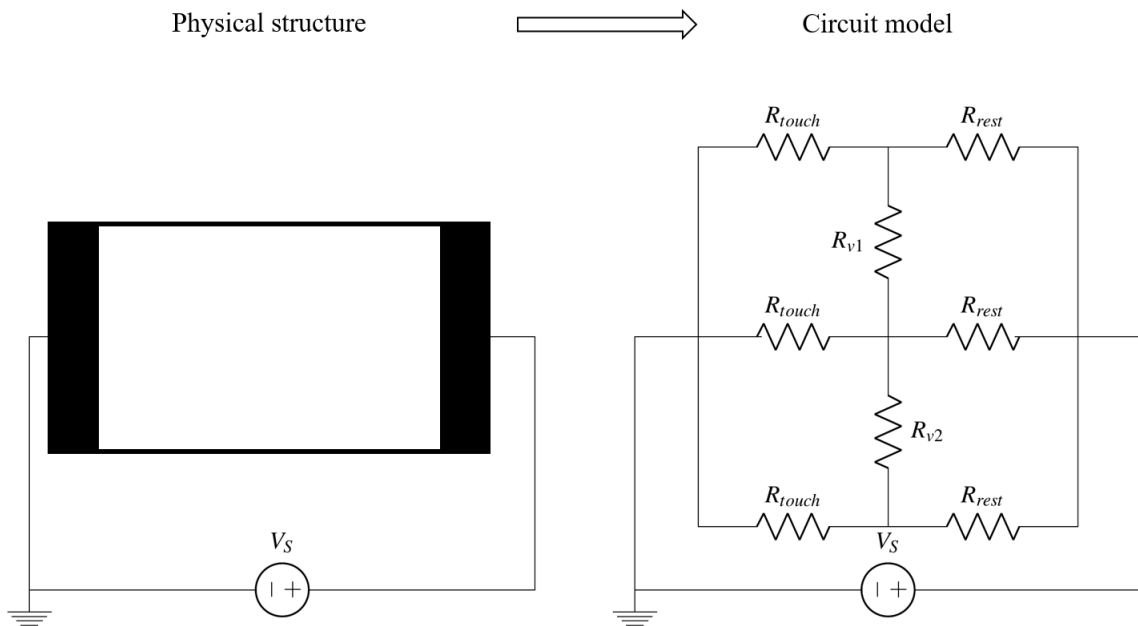

Let's analyze the circuit model for the bottom black plate:

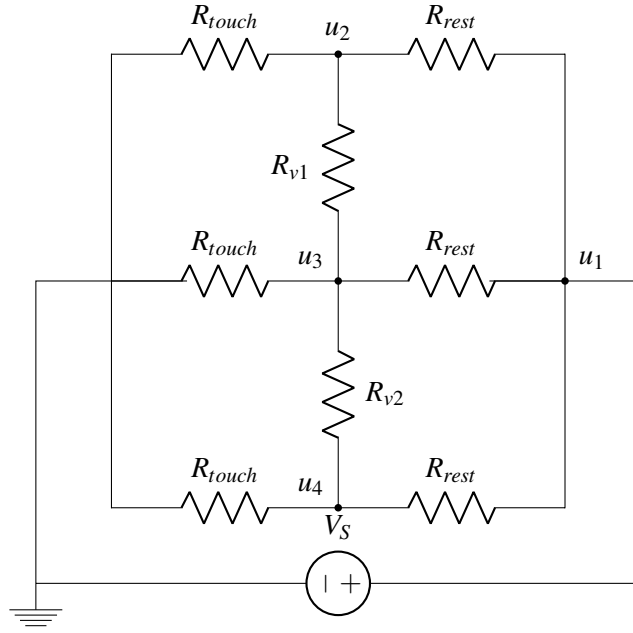

Similar to the analysis performed for the top red plate, we can derive u_3 , which is:

$$u_3 = \frac{R_{touch}}{R_{touch} + R_{rest}} \times V_s \quad (9)$$

Here, $R_{touch} = \rho \frac{L_{touch, horizontal}}{A}$ in which $L_{touch, horizontal}$ is the horizontal position touched.

The measurement of vertical and horizontal positions ($L_{touch, vertical}$, $L_{touch, horizontal}$) for a 2D touchscreen can be summarized as follows:

- **Vertical Position Measurement**

We connect a voltage source V_s to the top red plate and connect a voltmeter to the bottom black plate. We can map the voltage measured to the vertical position touched.

$$V_{out} = \frac{L_{touch, vertical}}{L} \times V_s. \quad (10)$$

- **Horizontal Position Measurement**

We connect a voltage source V_s to the bottom black plate and connect a voltmeter to the top red plate. We can map the voltage measured to the horizontal position touched.

$$V_{out} = \frac{L_{touch, horizontal}}{L} \times V_s. \quad (11)$$

The important simplification used is replacing R_{h1}, R_{h2} with open circuits for $L_{touch, horizontal}$ measurement, and replacing R_{v1}, R_{v2} for $L_{touch, vertical}$ measurement. However, this kind of simplification is valid only if the resistor is at (0, 0) on the I-V plot, which means the resistor has zero current flow and therefore zero voltage drop ($I \times R = V$).