EECS 16A Designing Information Devices and Systems I

Fall 2017 Official Lecture Notes Note 16(Draft)

Not only can circuit analysis be cumbersome to do by hand, but it can be difficult to even understand the high-level behavior of complicated circuits given a schematic. We need tools we can use to both lessen the burden of analysis and, more importantly, to help us think about circuits and understand how they behave. Ultimately our goal is to **design** more efficiently, and we will now start building up additional tools to do so.

16.1 Superposition

If we want to take a voltage source V and output a voltage within that range (αV where $0 \leq \alpha \leq 1$), what can we do? We can use a voltage divider! Now what if we want to take two voltage sources and add them together? In this section, we are going to look at circuits with multiple voltage or current sources. In particular, we would like to introduce a very useful idea in working circuits of this type – superposition.

Remember from basic mathematics that a linear function $f(x+y)$ can be decomposed into $f(x) + f(y)$. We know that everything we've learned so far in circuits is linear (think Ohm's Law). Because of the linearity property of circuits consisting of only resistors and voltage/current sources, we can add the response of each source to get the actual response. The idea is that we can compute the response of each source one at a time, ignoring the response of the rest of the sources. We then add together the solved circuit values from each individual source; the sum of all the individual sources is the “final result”, which will be equivalent to having solved the circuit with all the sources enabled at the same time.

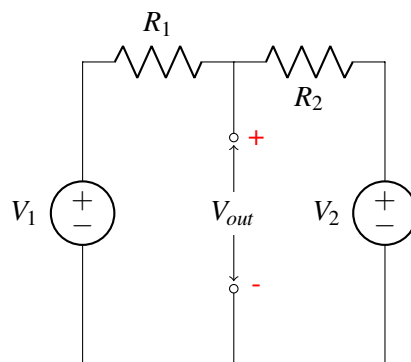

The procedure to do this (which is known as superposition) is as follows:

For each source k (either voltage source or current source)

Set all other *independent* sources to 0

- **Voltage source: replace with a wire**
- **Current source: replace with an open circuit**

Compute the circuit voltages and currents due to this source k

Compute V_{out} by summing the $V_{out,k}$ s for all k .

Now we ask the question: why does it make sense to replace voltage sources with wires? If we look at the I-V plot of a voltage source V_S , where I is the current going through the voltage source, then the plot would be a vertical line:

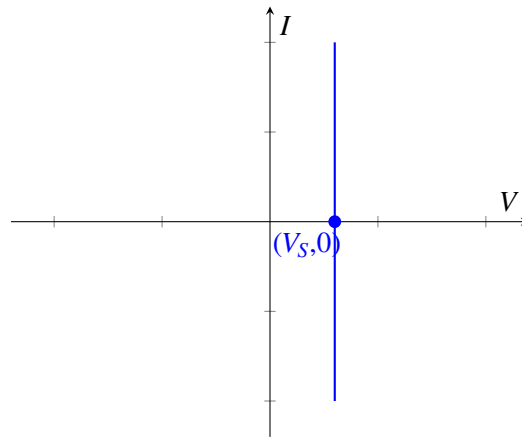

Now if we want to zero out this voltage source, we are setting $V_S = 0$. Then the I-V plot is exactly the y-axis.

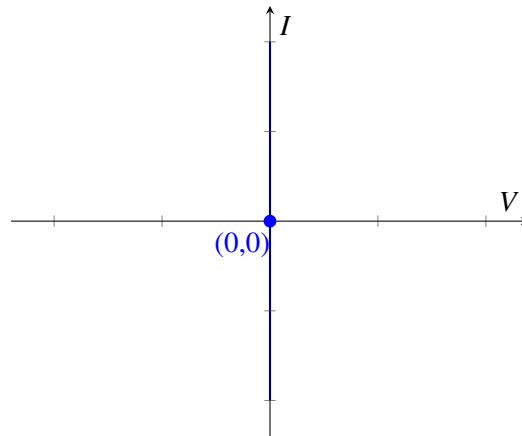

What does this mean? This means that it allows any current to go through, however the voltage drop always remains zero. This is exactly what a short circuit does.

Now let's look at why we replace current sources with open circuits. If we plot the I-V graph of a current source I_S , we get the following:

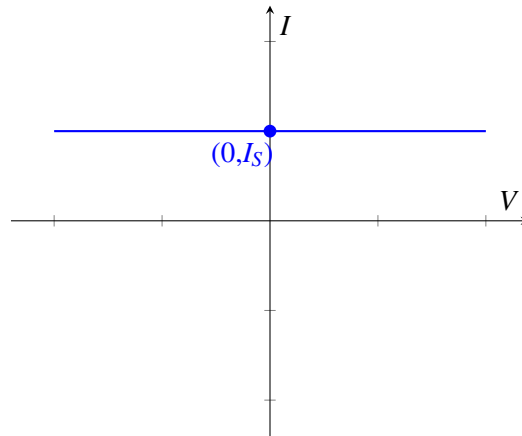

What if we turn off the current source? Then the I-V graph becomes the x-axis, i.e., the line $I = 0$.

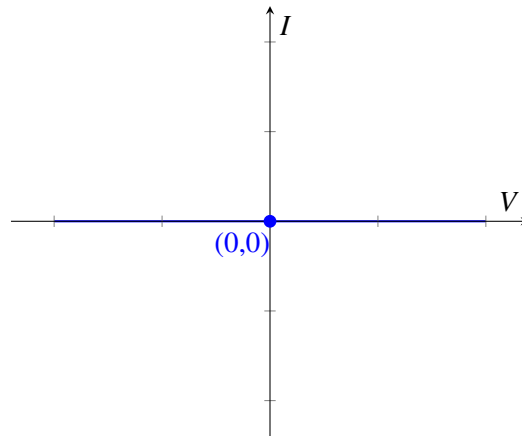

What does this mean? This means no matter what voltage you apply, there will be no current. This is equivalent to an open circuit.

We will illustrate this idea on the circuit above: We would like to figure out V_{out} . We first compute the output voltage due to V_1 and hence source V_2 will be replaced with a wire:

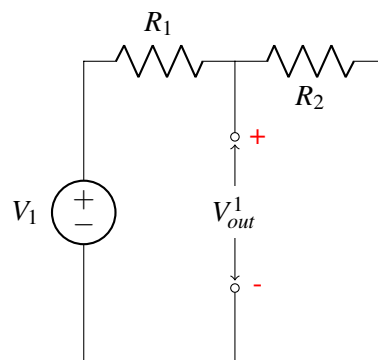

We can recognize this as just a voltage divider circuit, and therefore we know that $V_{out}^1 = \frac{R_2}{R_1+R_2}V_1$. Next we compute the output voltage due to V_2 and hence source V_1 will be replaced with a wire.

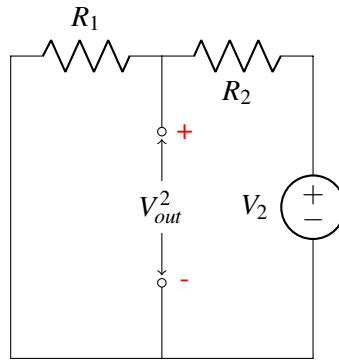

We again recognize that this is just a voltage divider circuit and therefore we can see that $V_{out}^2 = \frac{R_1}{R_1+R_2}V_2$. Finally, to get the output voltage V_{out} of the original circuit, we add the two output voltages based on the response of each voltage source together $V_{out} = V_{out}^1 + V_{out}^2 = \frac{R_2}{R_1+R_2}V_1 + \frac{R_1}{R_1+R_2}V_2$.

As a side note, we can apply the idea of replacing elements with equivalent elements (e.g. zero out voltage sources with wires) to resistors as well. We will try and demonstrate this graphically. Recall that by Ohm's law, the I-V graph across a resistor looks like

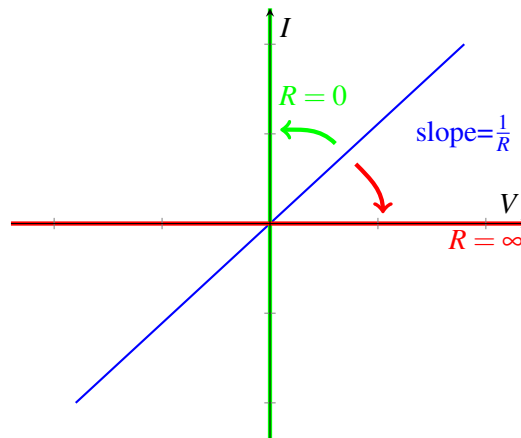

We know that the slope of the line is equal to $\frac{1}{R}$. What happens in the limit where R trends towards infinity? Then the line becomes the x-axis, which corresponds to an open circuit as we've seen earlier. Now what happens in the limit where R trends towards zero? The line becomes the y-axis, which corresponds to a wire.

To summarize, **zero voltage source and zero resistance are equivalent to short circuits; zero current source and infinite resistance are equivalent to open circuits.**

16.2 Equivalence

One aspect of circuit design that is distinctly different than most software engineering is that when we assemble a large circuit out of a component blocks, each of the blocks can potentially influence the behavior

of the others. Does this mean that every addition or change to a circuit means that we need to completely re-analyze the entire system? No, because luckily, the ways they interact are limited in a very specific way that we will discuss. It turns out they actually interact through only 2 parameters, current I and voltage V . This leads to a new tool we will develop to help us when describing more complicated/complete circuit models; the concept of equivalence.

Equivalent circuits are used to simplify interactions between circuits. Let's take the simplest case where interactions are only through one pair of nodes. In that case, we just have two possible quantities: the voltage across the nodes and the current flowing through the connections (by KCL these must be the same as long as arrows are drawn correctly). The relationship between this current and this voltage would then fully define the interactions between the circuits. This is where the idea of equivalence comes in. If we have a circuit that exhibits the same $I - V$ relationship from the standpoint of a pair of nodes, the other circuit (the one you are interacting with) can't tell the difference. The idea of equivalence is to be able to replace one (or both) of the interacting circuits with a simpler circuit that will give us the same overall behavior.

Before we move on, let's clarify what we mean by "equivalent"? **Two circuits are equivalent if the $I - V$ relationship of one is exactly identical to that of the other circuit. (As a reminder, the simplest $I - V$ relationship we've seen so far is for a resistor, i.e., $V = IR$ or $I = \frac{V}{R}$.** This is *exactly* what we mean by equivalence; be careful not to overextend this definition or apply others. For example, equivalence tells us nothing about the *power* in a circuit and one should be careful not to assume it does.

Now why is this possible intuitively? Since voltage and current are governed by a linear relationship for all of the circuit elements we've learned about, and a line can be uniquely determined by exactly two points, we can capture the original circuit with a simplified circuit that has exactly two components: a voltage (current) source and a resistor.

Definition 16.1 (equivalent circuit): If we pick two terminals within a circuit, we say that another circuit is **equivalent** to the original circuit if it exhibits the same $I - V$ relationship at those two terminals.

Note: From the standpoint of any other nodes in the circuit (i.e. any pairs of nodes), the circuit may or may not be equivalent. Furthermore, looking at the same circuit but examining a different pair of terminals may not produce equivalent $I - V$ relationship.

At a high level, what does it take (at a minimum) to construct a line? We can either use two points along the line, or one point and the slope of the line. Remember, the equivalent circuit of a circuit will have an identical IV curve, which is a line. In this class, we will construct these equivalent curves using a point and the slope. The two easiest points to collect along a line are the x-intercept (point with 0 current) and the y-intercept (point with 0 voltage). T

here are two types of equivalent circuits we will construct: the *Thevenin* and the *Norton*. For the Thevenin equivalent we look at the intersection with the x-axis (zero current); for the Norton, we look at the intersection with the y-axis (zero voltage).

Next we figure out the slope of the line; remember, for an $I \times V$ curve, the slope is equal to the resistance.

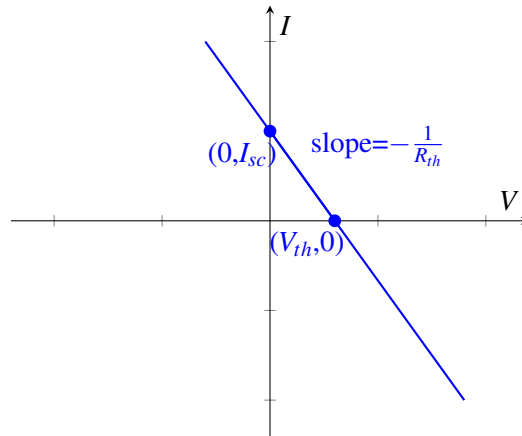

We call the first circuit below, containing a voltage source and a resistor the **Thevenin equivalent circuit**; we call the second circuit, containing a current source and a resistor, the **Norton equivalent circuit**. Once we simplify the original circuit to one of the above, we can easily figure out V_{out} no matter what resistor it is connected to on the right. In fact, we can convert **any** circuit into any one of the equivalent forms above.

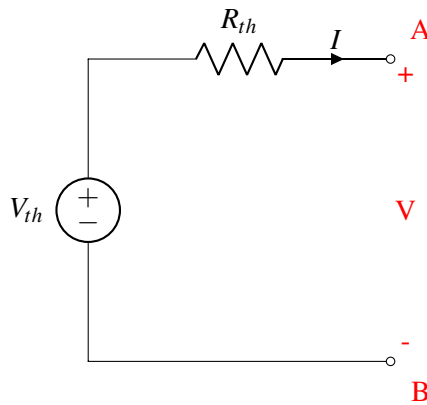

or

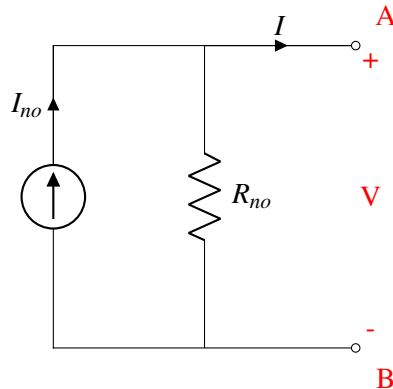

16.3 Thevenin Equivalent Circuit

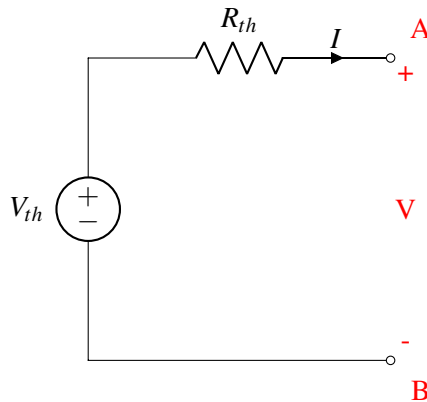

Now how would you figure out V_{th} and R_{th} for the Thevenin equivalent circuit?

Concretely, the procedure to solve for the Thevenin equivalent is as follows:

Step 1, find V_{Th} : Connect an open circuit across the two output terminals and measure the voltage across them. This measured V_{OC} equals V_{Th} .

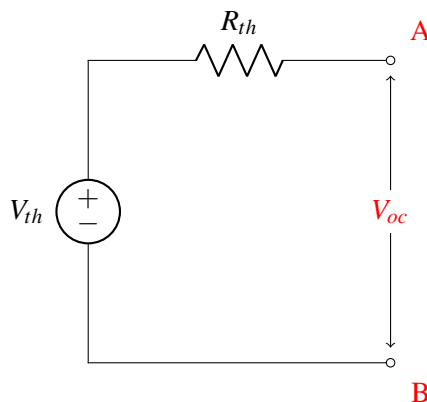

Step 2, find R_{Th} : Zero out any independent sources. Remember, this means voltage sources turn into a wire and current sources turn into an open circuit. Then apply either a test current into the terminal and measure the resultant voltage, or apply a test voltage and measure the resultant current. $R_{Th} = \frac{V_{test}}{I_{test}}$

16.4 Norton Equivalent Circuit

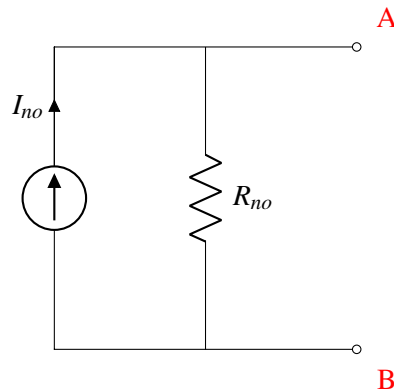

What about solving for the Norton equivalent circuit? It is important to note that R_N is equal to R_{Th} , meaning the slope of the IV curve is the same. Now, instead of looking at the V axis intercept, we find the intersection with the I -axis: At this point, the voltage across A and B is equal to zero, which is equivalent to shorting A and B . We denote the current at this point be I_{SC} .

To put it in terms of our standard procedure:

Step 1, find I_N : Connect a short circuit across the two output terminals and measure the current through it. This measured I_{SC} equals I_N .

Step 2, find R_N : Zero out any independent sources. Remember, this means voltage sources turn into a short circuit and current sources turn into an open circuit. Then apply either a test current into the terminal and measure the resultant voltage, or apply a test voltage and measure the resultant current. $R_{Th} = \frac{V_{test}}{I_{test}}$

Note that the second step doesn't change because R_N is equal to R_{Th} !

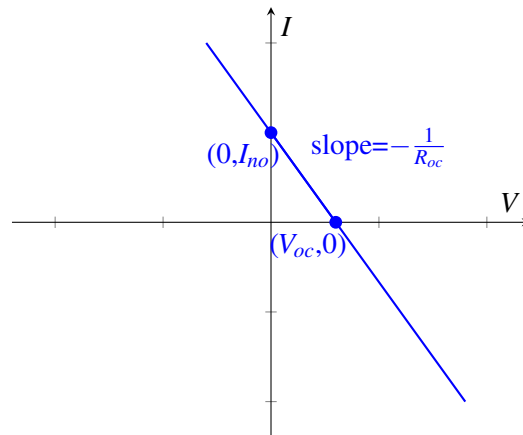

An interesting note is that we can move back and forth between Thevenin and Norton equivalent representations using their relationship through Ohm's Law. Because V_{Th} and I_N represent two points on the same line, we know that $I_{sc} = \frac{V_{Th}}{R_{th}}$ by Ohm's law. Hence, we can find both equivalent circuits by solving for just one. Conversely, we can solve for both V_{Th} and I_N and then find R_{Th} by computing $R_{Th} = \frac{V_{Th}}{I_N}$.

16.5 Equivalence Examples

Here will we find the Thevenin equivalents for a set of simple circuits.

16.5.1 Series Resistors

Consider the schematic:

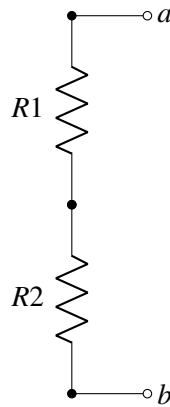

Let's follow the procedure given above.

Step 1: Note that there is already an open circuit is already connected between terminals a and b . In this case there is no voltage or current source in the circuit. Therefore, the voltage at every node is the same, and therefore, $V_{OC} = 0$. Remember, $V_{OC} = V_{Th}$, so $V_{Th} = 0$.

Step 2: There is no source to zero out in this case. Since it will turn out to be the easier choice, we will apply a test current and measure the resulting voltage, as shown:

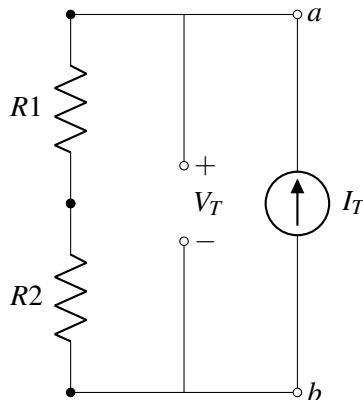

There is only one loop, and therefore all the currents in this circuit are the same.

$$V_{R1} = I_T R1 \quad (1)$$

$$V_{R2} = I_T R2 \quad (2)$$

$$V_T = V_{R1} + V_{R2} = I_T R1 + I_T R2 \quad (3)$$

$$V_T = (R1 + R2) I_T \quad (4)$$

$$R_{Th} = \frac{V_T}{I_T} = R1 + R2 \quad (5)$$

We see that equivalent resistance of these two resistors is simply their sum. We call these resistors in **series**. Note that in order to be in series, the resistors have to have the exact same current through them.

16.5.2 Parallel Resistors

Another way to arrange a circuit with two resistors and no voltage source is as follows:

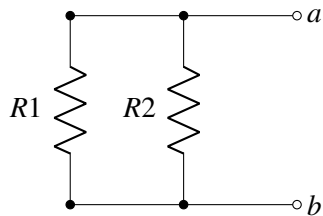

Let's again follow the procedure given above to find our equivalent circuit.

Step 1: Note that there is already an open circuit is already connected between terminals a and b . For the same reason as the prior example, $V_{OC} = 0$ in this case. Therefore, $V_{Th} = 0$.

Step 2: There is no source to zero out in this case. Since it will turn out to be the easier choice, apply a test voltage and measure the resulting current, as shown:

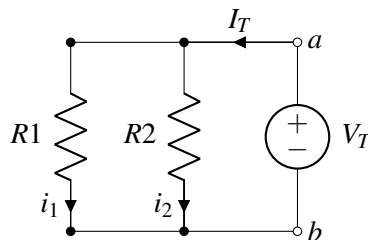

$$V_T = i_1 R_1 \quad (6)$$

$$i_1 = \frac{V_T}{R_1} \quad (7)$$

$$V_T = i_2 R_2 \quad (8)$$

$$i_2 = \frac{V_T}{R_2} \quad (9)$$

$$I_T = i_1 + i_2 = \frac{V_T}{R_1} + \frac{V_T}{R_2} \quad (10)$$

$$\frac{I_T}{V_T} = \frac{1}{R_{Th}} = \frac{1}{R_1} + \frac{1}{R_2} \quad (11)$$

Then, using simple algebra, for the case of just two resistors:

$$R_{Th} = \frac{R_1 \times R_2}{R_1 + R_2} \quad (12)$$

We call these resistors in **parallel**. Note that in order to be in parallel, the voltage across them has to be the same.

This mathematical relationship comes up often enough that it actually has a name: the “parallel operator“, \parallel . When we say $x \parallel y$, it means $\frac{x \times y}{x + y}$. Note that this is a mathematical operator and does not say anything about the actual configuration. In the case of resistors the parallel operator is used for parallel resistors, but for other components (like capacitors) this is *not* the case.

From these analyses, we now have a simple rule to tell if elements are in series or parallel. Series elements will have the exact same current through them due to KCL. Parallel elements will have the exact same voltage across them due to KVL. Another way to think about this is that series elements share exactly one node, while parallel elements will share two.

16.5.3 Voltage Divider

Now let's apply our analysis above to a voltage divider circuit shown below (which is very similar to the touchscreen). To figure out V_{th} , we solve for V_{oc} in the following circuit

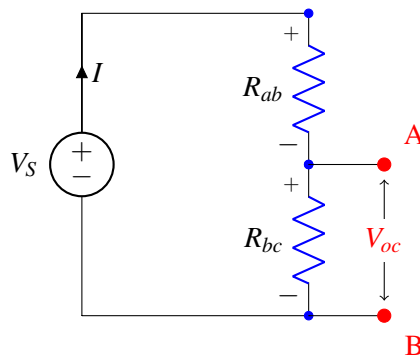

Note that the same current flows through the two resistors and that $V_{Rab} = V_s - V_{oc}$. Therefore, using Ohm's Law:

$$\frac{V_{Rab}}{R_{ab}} = \frac{V_{oc}}{R_{bc}} \quad (13)$$

$$\frac{V_s - V_{oc}}{R_{ab}} = \frac{V_{oc}}{R_{bc}} \quad (14)$$

$$\frac{V_s}{R_{ab}} - \frac{V_{oc}}{R_{ab}} = \frac{V_{oc}}{R_{bc}} \quad (15)$$

$$V_{oc} = \frac{R_{bc}}{R_{ab}R_{bc}} V_s \quad (16)$$

To figure out R_{th} , we zero out the independent source and apply a test voltage, measuring the resultant current.

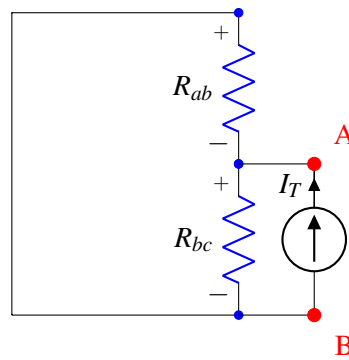

We can see that this is the same as the parallel resistor case we examined above: therefore, $R_{Th} = \frac{V_T}{I_T} = R_{ab} \parallel R_{bc}$.

This gives us a resulting Thevenin equivalent circuit of:

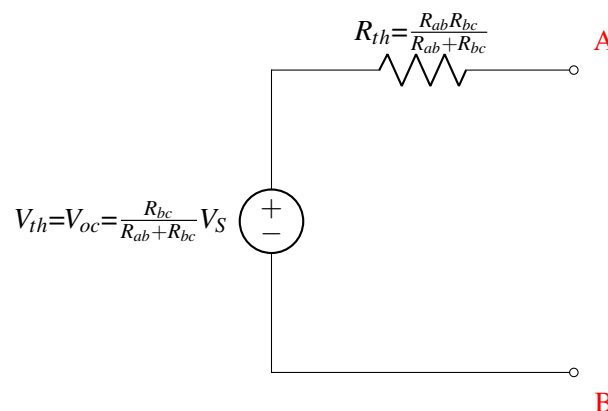

If we instead chose the upper two nodes (instead of the lower two nodes) as the two terminals (nodes A and B) as follows for the same exact circuit and find an equivalent Thevenin circuit from the standpoint of these two nodes,

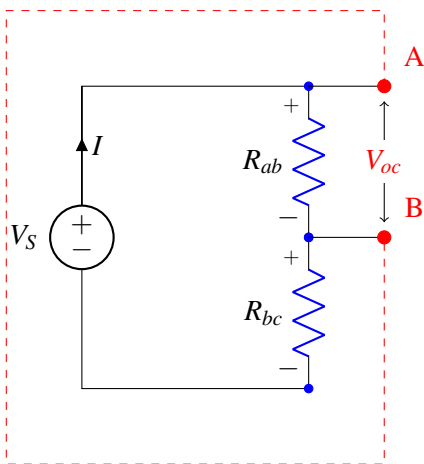

it can be easily seen by following the same procedure that

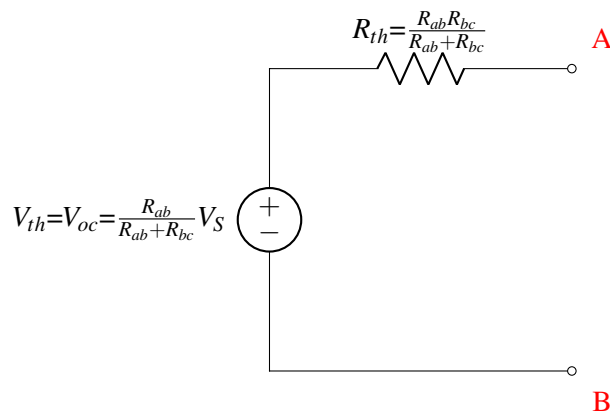

This is not the same result! This simple example shows how picking two different nodes in the same circuit and finding equivalent circuits will produce a different results. (And more generally, all circuits may or may not behave in the same from the standpoint of any two nodes) This is an important distinction to be made when looking at equivalent circuits. We are simply finding an equivalent circuit from the standpoint of a pair of terminals.