

EECS 42 Introduction to Electronics for Computer Science

**Andrew R. Neureuther
MW 3-4, 10 Evans
Plus Discussion Section**

<http://inst.EECS.Berkeley.EDU/~ee42/>

EECS 42 Course Overview

Some questions will this course may answer:

- **How do electronic circuits work (e.g. how do they amplify, how do they represent 1's and 0's, how do they perform logic) ?**
- **What determines performance (e.g. why is the Intel P4 so slow and a power hog, and how will they fix it) ?**
- **Why is CMOS dominant and why will it continue it's dominance (e.g. versus bipolar or new technologies)?**
- **What does CMOS look like (under the microscope) ?**
- **What is the future prognosis for performance of computers ?**
- **Why are analog circuits so important in this digital world ?**

Goals of EECS 42

- **Provide an overview of electronics**
 - Terminology
 - Organization of the field
- **Provide career foundation cornerstones**
 - Skills – circuit analysis
 - Performance estimates – what sets fundamental limits
 - Examples of modern and changing technology

Course Overview

EECS 42 – Electronics for Computer Science

- Introduces “hardware” side of EECS

Course content : (Not precisely in this order)

- Basic Device and Circuit Ideas
- Digital Circuits and Logic Delays
- Physical realization/CMOS
- Performance limits of CMOS digital circuits

PULSE: Output is Rising exponential then Falling exponential

Lecture 7

Example: Switch rises at $t = 0$, falls at $t = 0.1, 1$ or $10 \mu\text{sec}$ (Do $1 \mu\text{sec}$ case)

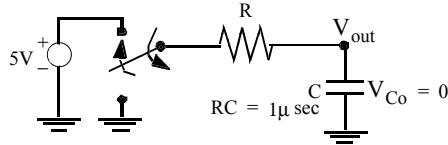

Now starting at $1 \mu\text{sec}$ we are discharging the capacitor so the form is a falling exponential with initial value 3.16 V :

Solution: for $RC = 1 \mu\text{sec}$: during the first rise V obeys:

$$V = 5 \left[1 - e^{-\frac{t}{10^{-6}}} \right]$$

Thus at $t = 1 \mu\text{sec}$, rising voltage reaches

$$5 \left[1 - e^{-1} \right] = 3.16 \text{ V}$$

What is equation?

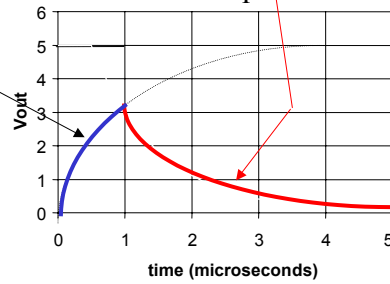

EXAMPLE WITH BOTH SPECIAL CASES

Lecture 8

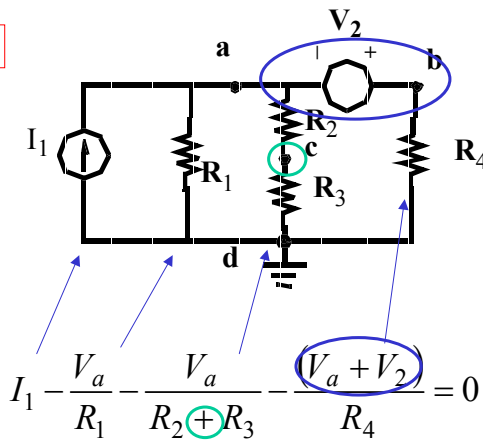

Lecture 11

TIMING DIAGRAMS

Version Date 01/21/03

Show transitions of variables vs time

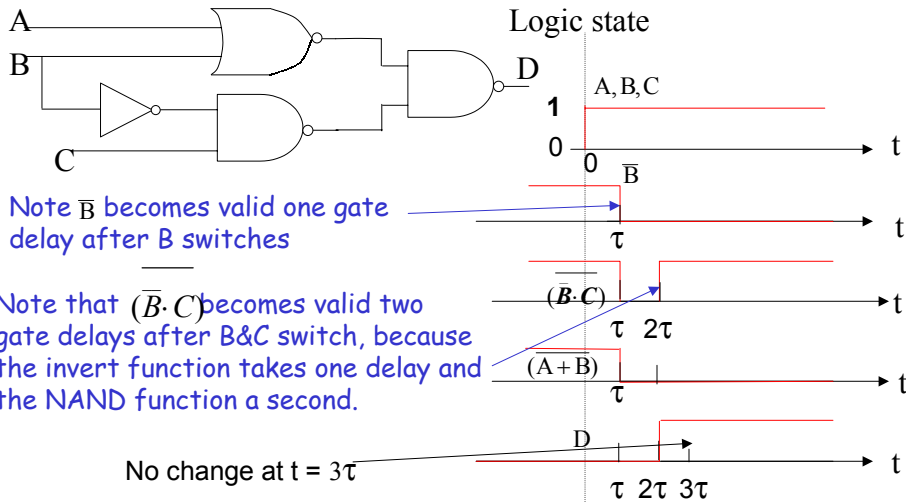

Copyright 2001, Regents of University of California

Lecture 14

CASCADE OP-AMP CIRCUITS

Version Date 01/21/03

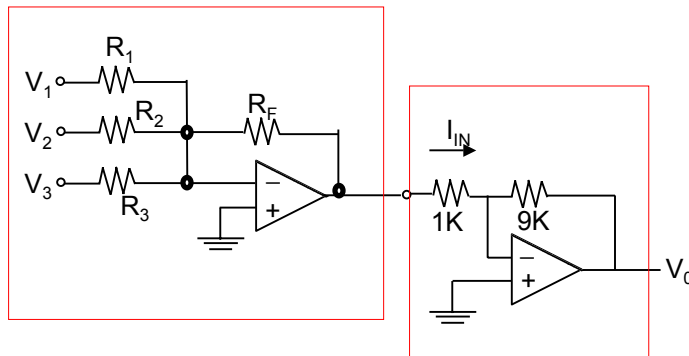

How do you get started on finding V_0 ?

Hint: Identify Stages

Hint: I_{IN} does not affect V_{O1}

See the further examples of op-amp circuits in the reader

Copyright 2001, Regents of University of California

Composite Current Plot for the 42PD Circuit with 200kΩ Load to Ground

Lecture 15

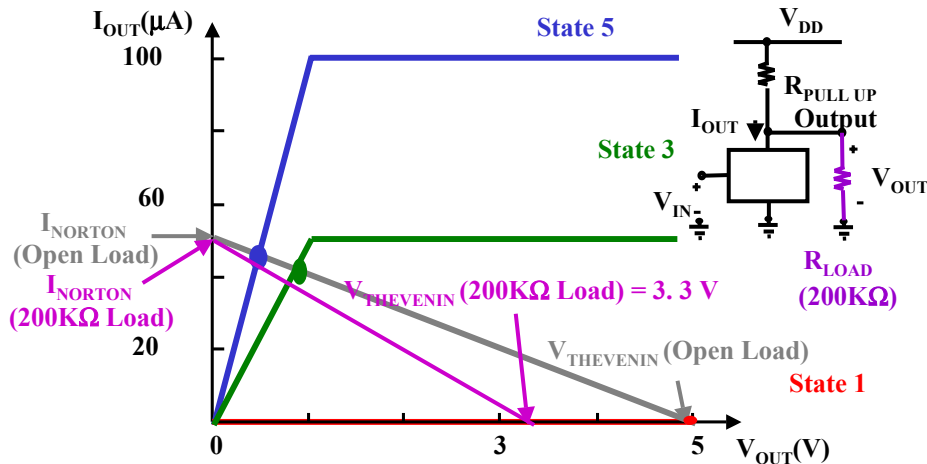

Copyright 2001, Regents of University of California

Logic Gate Propagation Delay (Cont.)

Lecture 17

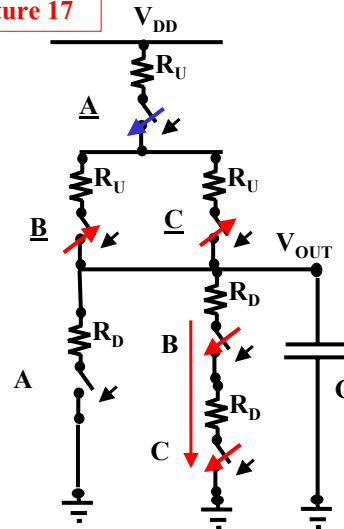

At $t=0$, B and C switch to high = V_{DD} and A remains low.

C_{OUT} discharges through the pull-down resistance of gates B and C in series.

$$\Delta t = 0.69(R_{DB} + R_{DC})C_{OUT} = 0.69(20k\Omega)(50fF) = 690 \text{ ps}$$

The propagation delay is **two times longer** than that for the inverter!

Copyright 2001, Regents of University of California

Combinatorial Logic and Clocked Latches: Signal Flow

HW 13
Lecture 25

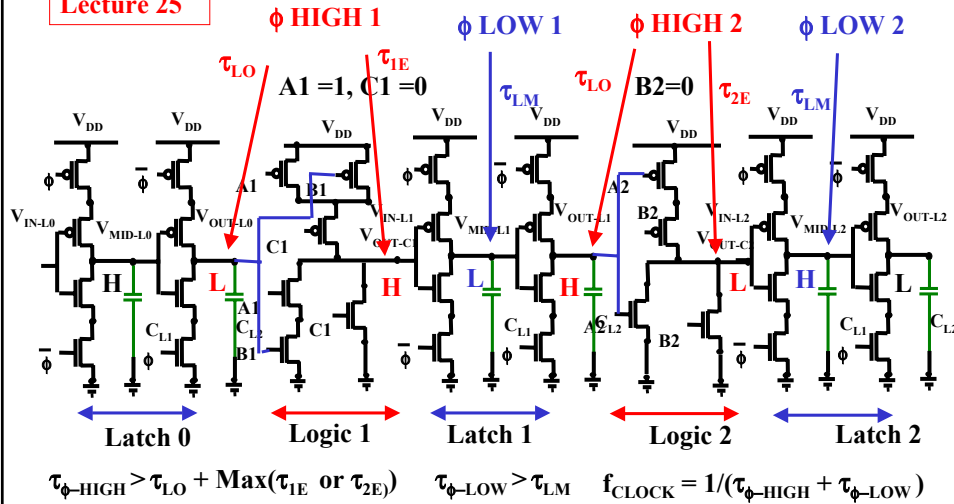

Copyright 2001, Regents of University of California

The Parallel Lab for EECS 42

Why Take EECS 43 (The first lab)

- Its fun (actually!)
- You will do better in EE42.
- If you take any later labs (like CS150, EE142) you will be much better prepared.
- You will learn a few skills and make a robot

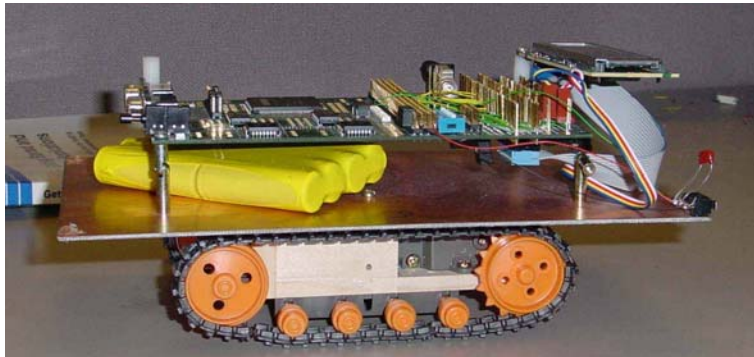

Copyright 2001, Regents of University of California

Instructional Team

- **Professor Andrew R. Neureuther, 510 Cory**
Office hours 11 M, Tu, W, (Th), F
<http://divine.eecs.berkeley.edu/~neureuth/>
neureuth@eecs.berkeley.edu, 642-4590
Background: IC Technology and Process Simulation
- **Teaching Assistants: Great Person in CAD!**
Farinaz Koushanfar
Sections and office hours 179M Cory: TBA

Go to section Monday Jan 27th!

EECS 42 - Mechanics

- Text Book – Schwarz and Oldham, 2nd ed., 1993
- Lectures - on web but **you must print your copies**
- Discussion Sections: M 9 247 Cory; W 10 293 Cory; **Th 3 likely dropped** (decision 1/24/03)
- Homework – Out Monday. Due 2:30 Wed week in box in hall near 275 Cory (**not accepted in class**). Returned in Section. **You must do your own work.**
- Exams – Mar 5; April 16; May 20 5-8 7; in class, closed book, formula sheet provided.
- Grading – 5% HW, 23% M1 and M2, 49% Final
- Web gives more details including lecture plan.

Game Plan 01/22/03

Today:

- ☐ **Signals, Analog and Digital**
Schwarz and Oldham : 1.1-1.2

Monday 01/27/03

- ☐ **Electrical Quantities**
Schwarz and Oldham: 1.3-1.4

Wednesday 01/29/03

- ☐ **Kirchhoff Laws**
Schwarz and Oldham: 2.1-2.2

Problem Set #1 - Out 1/22/03 - Due 1/27/03 2:30 in box near 275 Cory

Practice Skills needed for Electronics without Electronics

1.1 Flow; 1.2 Potential; 1.3 Truth Table; 1.4 Graphs

Analog versus Digital Electronics

- Most (but not all) observables are analog
think of analog versus digital watches
- But the most convenient way to represent and transmit information electronically is digital
think of audio recordings
- Analog/Digital and Digital/Analog conversion is essential (and nothing new)
think of a piano keyboard

Analog Example:

Version Date 01/21/03

Analog signal (microphone voltage) representing piano key A (440 Hz)..

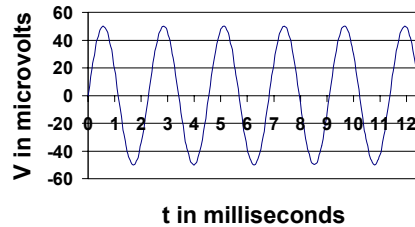
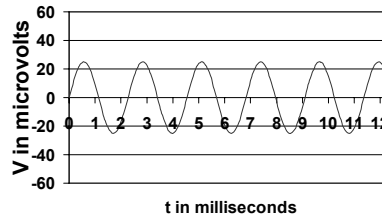
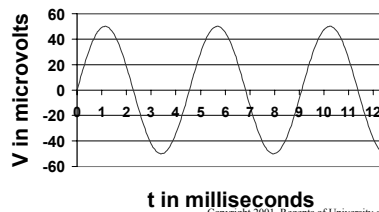
50 microvolt 440 Hz signal**25 microvolt 440 Hz signal****Microphone voltage with normal key stroke****50 microvolt 220 Hz signal****Microphone voltage with soft pedal**

Analog signal representing piano A, but one octave below middle A (220 Hz)

Copyright 2001, Regents of University of California

Version Date 01/21/03

Analog Signals

- May have very physical relationship to information presented
- In the simplest, are direct waveforms of information vs time
- In more complex cases, may have information modulated on a carrier as in AM or FM radio

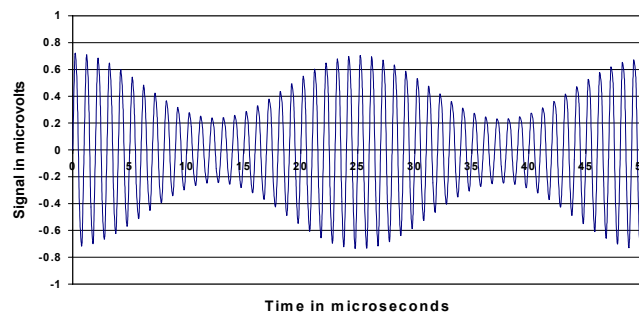
Amplitude Modulated Signal

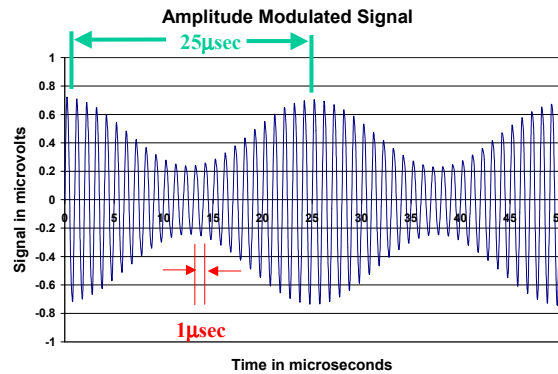

Parameters of sin waves:
 Period (time to repeat)
 Frequency (1/period)
 Phase
 Amplitude

Note: The period of the carrier is $1\mu\text{sec}$ * (that is, the frequency is 1MHz)
 The period of the modulation is $25\mu\text{sec}$ (that is, the frequency is 40kHz)
 The amplitude of the modulation is about 50% of the maximum possible
 What is the equation of this waveform (just for fun)??

Answer: V (in microvolts) = $[.5 + .25 \cos (2\pi \times 40 \times 10^3 t)] \times \sin (2\pi \times 10^6 t)$

Digital Signal Representations

(Analog to Digital Conversion)

By using binary numbers we can represent any quantity. For example a binary two (**10**) could represent a 2 Volt signal. But we generally have to agree on some sort of "code" and the dynamic range of the signal in order to know the form and the minimum number of bits.

Example: We want to encode to an accuracy of one part in 64 (i.e. 1.5% precision). It takes 6 binary digits (or "bits") to represent any number 0 to 63.

Example: Possible digital representation for a pure sine wave of known frequency. We must choose maximum value and "resolution" or "error," then we can encode the numbers. Suppose we want $1\mu\text{V}$ accuracy of amplitude with maximum amplitude of $50\mu\text{V}$, We could use a simple pure binary code with 6 bits of information. (Why 6 bits.... What if we only use 5?)

Answer: with 5 binary digits we can represent only 32 values

Digital Signal Representations

Example: Possible digital representation for the sine wave signals, and highlighting our maximum possible 50 μ V sine wave

Amplitude in μ V	Binary representation
1	000001
2	000010
3	000011
4	000100
5	000101
etc.	
8	001000
16	010000
32	100000
50 (= 32+16+2)	110010
63	111111

Copyright 2001, Regents of University of California

Digital Representations of Logical Functions

Digital signals also offer an effective way to execute logic. The formalism for performing logic with binary variables is called **Switching Algebra or Boolean Algebra**.

In switching algebra we have only “**true**” and “**false**” conditions, usually represented by binary 1 and 0, respectively. Thus stating that “A is true” and “B is false” is equivalent to stating **A=1** and **B=0**.

The utility of switching algebra is that we can perform elaborate logical operations with simple Boolean arithmetic. All modern control systems are digital, utilizing this approach.

Thus digital electronics combines two important properties: 1) The ability to represent real functions by coding the information in digital form, and 2) The ability to control a system by a process of manipulation and evaluation of digital variables using switching algebra.

Copyright 2001, Regents of University of California

So Why Digital?

(For example, why CDROM audio vs vinyl recordings?)

- Digital signals can be transmitted, received, amplified, and re-transmitted with **no degradation**.
- Binary numbers are a natural method of expressing logical variables.
- Complex logical functions are easily expressed as binary functions (e.g., in control applications).
- Digital signals are easy to manipulate (as we shall see).
- With digital representation, we can achieve arbitrary levels of “dynamic range,” that is, the ratio of the largest possible signal to the smallest than can be distinguished above the background noise
- Digital information is easily and **inexpensively stored** (in Disk, CDROM, DVD, RAM, ROM, EPROM, etc.), again with arbitrary accuracy.

Are Voltages in a Digital Circuit “0’s” and “1’s” ?³

(For example, in a RAM or Microprocessor)

- Well, on a static basis we represent “0” by some voltage range (say 0 to 0.1V). And on a static basis we represent “1” by another voltage range (say 1.5 to 2.0V).
- So if nothing is changing, most of the nodes are at logical zero or one.
- But we are in a hurry to get the answer, so when the circuit is active we actually **evaluate the logical state before it reaches the static value** (just like the press evaluates the outcome of the election before all the votes are in). We are really dealing with analog information.
- Moreover in lots of circuits (such as RAMs) there are places where the signals are much smaller than the official logic assignments. These signals are **amplified** in linear (or nonlinear) fashion, a classical analog operation.
- If you use a modem connection to the internet, you are sending analog information to represent digital (to sneak by the bandwidth filters).

Are Voltages in a Digital Circuit “0’s” and “1’s” ? (continued)

Clever encoding methods (as opposed to simple digital representation) can lead to cost, size, and performance advantages:

Example: Telephone Dialing

- 1950: “Pulse dialing” Six pulses represented 6, etc.
- Improvement: “Tone dialing” Each number represented by a combination of tones (tones that are within the limited frequency bandwidth of telephones.
- Analog modem technology: Uses combination of amplitude and phase modulation to represent digital information. This is done because the telephone lines are filtered to stop all frequencies above 2kHz. Sending simple pulses would limit us to a few Kbits/sec maximum.

Copyright 2001, Regents of University of California

So need a computer scientist know about electronics ?

(Impossible to answer, but...)

- Knowing something about physical nature of information (voltages and currents) can be useful in understanding what goes in and out of a computer, memory, radio, etc
- Knowing something about the electronic devices (e.g. CMOS) can be useful in understanding the restrictions on size, weight and performance of working systems.
- Learning enough electronics to be able to carry out simple performance and power calculations can be useful understanding the limits of actual physical hardware.
- Folks who know both hardware and software are extremely valuable in product design. (\$\$\$\$\$)

Copyright 2001, Regents of University of California