

CSI62
Operating Systems and
Systems Programming
Lecture 14

Caching (Finished),
Demand Paging

October 11th, 2017
Neeraja J. Yadwadkar
<http://cs162.eecs.Berkeley.edu>

Recall: Caching Concept



- **Cache**: a repository for copies that can be accessed more quickly than the original
 - Make frequent case fast and infrequent case less dominant
- Caching underlies many techniques used today to make computers fast
 - Can cache: memory locations, address translations, pages, file blocks, file names, network routes, etc...

11/11/17

CS162 @UCB Fall 17

Lec 14.2

Recall: In Machine Structures (eg. 61C) ...

- Caching is the key to memory system performance

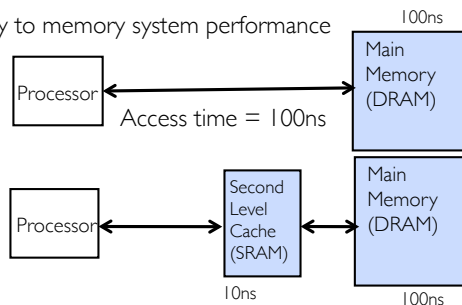

$$\text{Average Access time} = (\text{Hit Rate} \times \text{HitTime}) + (\text{Miss Rate} \times \text{MissTime})$$

$$\text{HitRate} + \text{MissRate} = 1$$

$$\text{HitRate} = 90\% \Rightarrow \text{Avg. Access Time} = (0.9 \times 10) + (0.1 \times 100) = 19\text{ns}$$

$$\text{HitRate} = 99\% \Rightarrow \text{Avg. Access Time} = (0.99 \times 10) + (0.01 \times 100) = 10.9\text{ ns}$$

11/11/17

CS162 @UCB Fall 17

Lec 14.3

Caching Applied to Address Translation

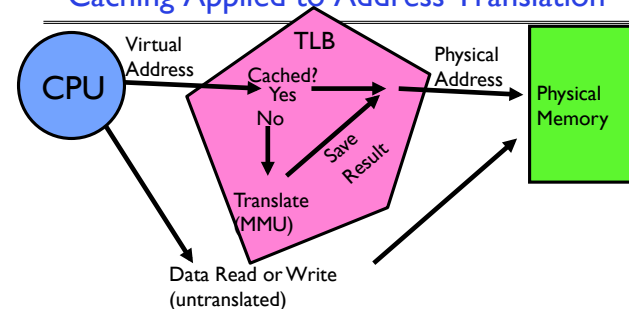

- Question is one of page locality: does it exist?
 - Instruction accesses spend a lot of time on the same page (since accesses sequential)
 - Stack accesses have definite locality of reference
 - Data accesses have less page locality, but still some...
- Can we have a TLB hierarchy?
 - Sure: multiple levels at different sizes/speeds

11/11/17

CS162 @UCB Fall 17

Lec 14.4

Recall: What Actually Happens on a TLB Miss?

- Software traversed Page tables (like MIPS)
 - On TLB miss, processor receives TLB fault
 - Kernel traverses page table to find PTE
 - » If PTE valid, fills TLB and returns from fault
 - » If PTE marked as invalid, internally calls Page Fault handler
- Hardware traversed page tables:
 - On TLB miss, hardware in MMU looks at current page table to fill TLB (may walk multiple levels)
 - » If PTE valid, hardware fills TLB and processor never knows
 - » If PTE marked as invalid, causes Page Fault, after which kernel decides what to do afterwards)
- Most chip sets provide hardware traversal
 - Modern operating systems tend to have more TLB faults since they use translation for many things
 - Examples:
 - » shared segments
 - » user-level portions of an operating system

11/11/17

CS162 @UCB Fall 17

Lec 14.5

Transparent Exceptions: TLB/Page fault (1/2)

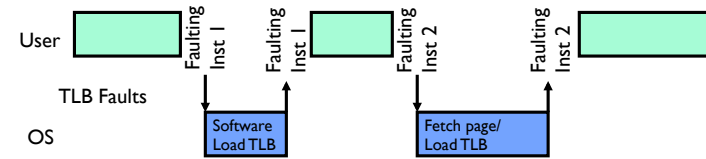

- How to transparently restart faulting instructions?
 - (Consider load or store that gets TLB or Page fault)
 - Could we just skip faulting instruction?
 - » No: need to perform load or store after reconnecting physical page

11/11/17

CS162 @UCB Fall 17

Lec 14.6

Transparent Exceptions: TLB/Page fault (2/2)

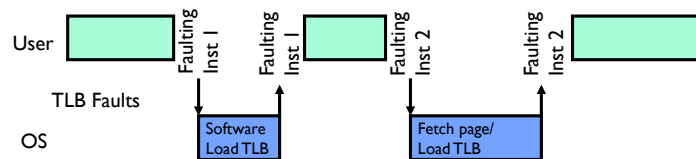

- Hardware must help out by saving:
 - Faulting instruction and partial state
 - » Need to know which instruction caused fault
 - » Is single PC sufficient to identify faulting position????
 - Processor State: sufficient to restart user thread
 - » Save/restore registers, stack, etc
- What if an instruction has side-effects?

11/11/17

CS162 @UCB Fall 17

Lec 14.7

Consider weird things that can happen

- What if an instruction has side effects?
 - Options:
 - » Unwind side-effects (easy to restart)
 - » Finish off side-effects (messy!)
 - Example 1: `mov (sp)+, 10`
 - » What if page fault occurs when write to stack pointer?
 - » Did `sp` get incremented before or after the page fault?
 - Example 2: `strcpy (r1), (r2)`
 - » Source and destination overlap: can't unwind in principle!
 - » IBM S/370 and VAX solution: execute twice – once read-only
- What about "RISC" processors?
 - For instance delayed branches?
 - » Example: `bne somewhere`
`ld r1, (sp)`
 - » Precise exception state consists of two PCs: PC and nPC (next PC)
 - Delayed exceptions:
 - » Example: `div r1, r2, r3`
`ld r1, (sp)`
 - » What if takes many cycles to discover divide by zero, but load has already caused page fault?

11/11/17

CS162 @UCB Fall 17

Lec 14.8

Precise Exceptions

- Precise \Rightarrow state of the machine is preserved as if program executed up to the offending instruction
 - All previous instructions **completed**
 - Offending instruction and all following instructions act **as if they have not even started**
 - Same system code will work on different implementations
 - Difficult in the presence of pipelining, out-of-order execution, ...
 - MIPS takes this position
- Imprecise \Rightarrow system software has to figure out what is where and put it all back together
- Performance goals often lead to forsaking precise interrupts
 - system software developers, user, markets etc. usually wish they had not done this
- Modern techniques for out-of-order execution and branch prediction help implement precise interrupts

11/11/17

CS162 @UCB Fall 17

Lec 14.9

Recall: TLB Organization

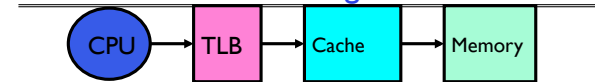

- Needs to be really fast
 - Critical path of memory access
 - » In simplest view: before the cache
 - » Thus, this adds to access time (reducing cache speed)
 - Seems to argue for Direct Mapped or Low Associativity
- However, needs to have very few conflicts!
 - With TLB, the Miss Time extremely high!
 - This argues that cost of Conflict (Miss Time) is much higher than slightly increased cost of access (Hit Time)
- Thrashing: continuous conflicts between accesses
 - What if use low order bits of page as index into TLB?
 - » First page of code, data, stack may map to same entry
 - » Need 3-way associativity at least?
 - What if use high order bits as index?
 - » TLB mostly unused for small programs

11/11/17

CS162 @UCB Fall 17

Lec 14.10

Reducing translation time further

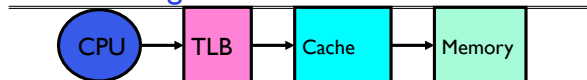

- As described, TLB lookup is in serial with cache lookup:

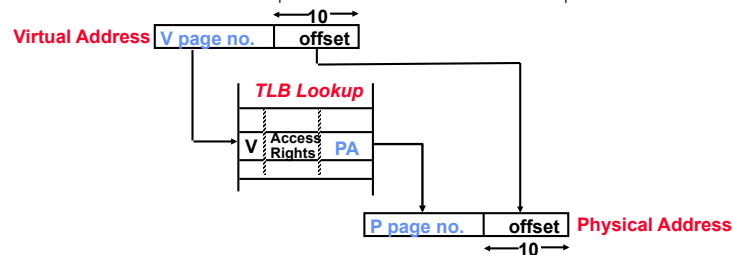

- Machines with TLBs go one step further: they overlap TLB lookup with cache access.
 - Works because offset available early

11/11/17

CS162 @UCB Fall 17

Lec 14.11

Overlapping TLB & Cache Access (1/2)

- Main idea:
 - Offset in virtual address exactly covers the “cache index” and “byte select”
 - Thus can select the cached byte(s) in parallel to perform address translation

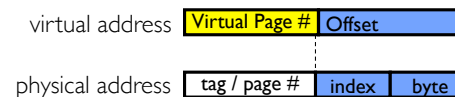

11/11/17

CS162 @UCB Fall 17

Lec 14.12

Overlapping TLB & Cache Access

- Here is how this might work with a 4K cache:

- What if cache size is increased to 8KB?
 - Overlap not complete
 - Need to do something else. See CS152/252
- Another option: Virtual Caches
 - Tags in cache are virtual addresses
 - Translation only happens on cache misses

1/1/17 CS162 @UCB Fall 17 Lec 14.13

Putting Everything Together: Address Translation

1/1/17 CS162 @UCB Fall 17 Lec 14.14

Putting Everything Together: TLB

1/1/17 CS162 @UCB Fall 17 Lec 14.15

Putting Everything Together: Cache

1/1/17 CS162 @UCB Lec 14.16

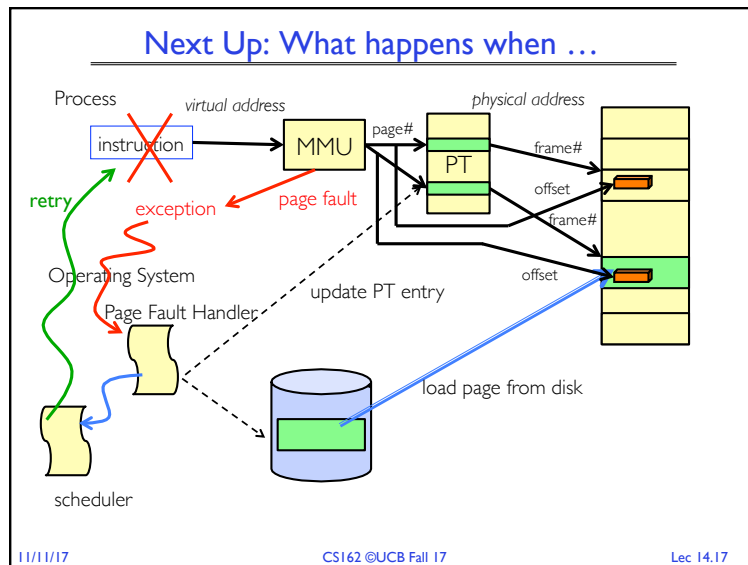

BREAK

11/11/17 CS162 @UCB Fall 17 Lec 14.18

- ### Where are all places that caching arises in OSes?
- Direct use of caching techniques
 - TLB (cache of PTEs)
 - Paged virtual memory (memory as cache for disk)
 - File systems (cache disk blocks in memory)
 - DNS (cache hostname => IP address translations)
 - Web proxies (cache recently accessed pages)
 - Which pages to keep in memory?
 - All-important "Policy" aspect of virtual memory
 - Will spend a bit more time on this in a moment
- 11/11/17 CS162 @UCB Fall 17 Lec 14.19

- ### Impact of caches on Operating Systems (1/2)
- Indirect - dealing with cache effects (e.g., sync state across levels)
 - Maintaining the correctness of various caches
 - E.g., TLB consistency:
 - » With PT across context switches ?
 - » Across updates to the PT ?
 - Process scheduling
 - Which and how many processes are active ? Priorities ?
 - Large memory footprints versus small ones ?
 - Shared pages mapped into VAS of multiple processes ?
- 11/11/17 CS162 @UCB Fall 17 Lec 14.20

Impact of caches on Operating Systems (2/2)

- Impact of thread scheduling on cache performance
 - Rapid interleaving of threads (small quantum) may degrade cache performance
 - » Increase average memory access time (AMAT) !!!
- Designing operating system data structures for cache performance

11/11/17

CS162 @UCB Fall 17

Lec 14.21

Working Set Model

- As a program executes it transitions through a sequence of “working sets” consisting of varying sized subsets of the address space

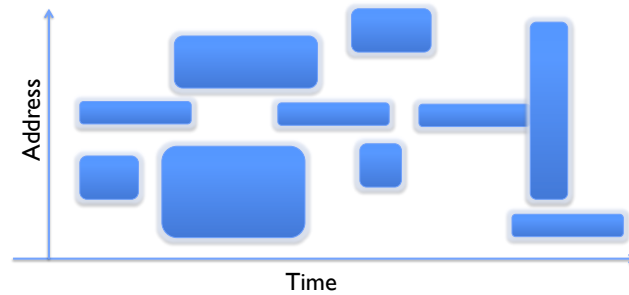

11/11/17

CS162 @UCB Fall 17

Lec 14.22

Cache Behavior under WS model

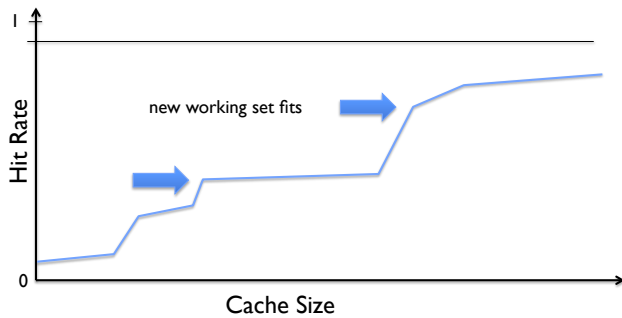

- Amortized by fraction of time the Working Set is active
- Transitions from one WS to the next
- Capacity, Conflict, Compulsory misses
- Applicable to memory caches and pages. Others ?

11/11/17

CS162 @UCB Fall 17

Lec 14.23

Another model of Locality: Zipf

$$P \text{ access}(\text{rank}) = 1/\text{rank}$$

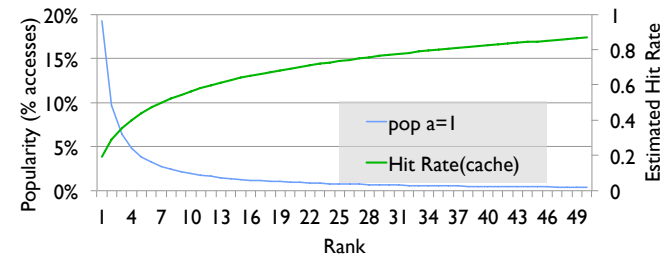

- Likelihood of accessing item of rank r is $\propto 1/r^a$
- Although rare to access items below the top few, there are so many that it yields a “heavy tailed” distribution
- Substantial value from even a tiny cache
- Substantial misses from even a very large cache

11/11/17

CS162 @UCB Fall 17

Lec 14.24

Demand Paging

- Modern programs require a lot of physical memory
 - Memory per system growing faster than 25%-30%/year
- But they don't use all their memory all of the time
 - 90-10 rule: programs spend 90% of their time in 10% of their code
 - Wasteful to require all of user's code to be in memory
- Solution: use main memory as cache for disk

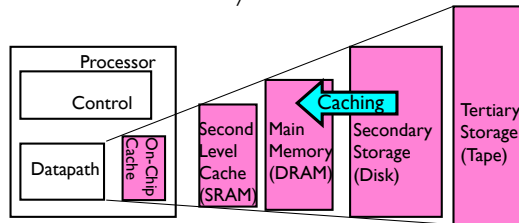

11/11/17

CS162 @UCB Fall 17

Lec 14.25

Illusion of Infinite Memory (1/2)

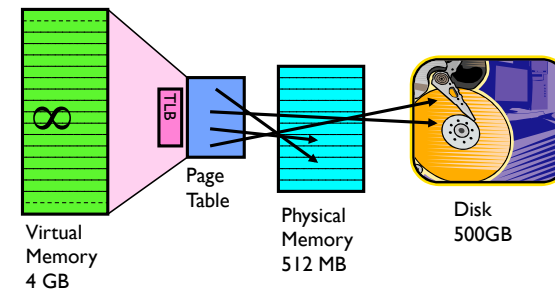

- Disk is larger than physical memory \Rightarrow
 - In-use virtual memory can be bigger than physical memory
 - Combined memory of running processes much larger than physical memory
 - » More programs fit into memory, allowing more concurrency

11/11/17

CS162 @UCB Fall 17

Lec 14.26

Illusion of Infinite Memory (2/2)

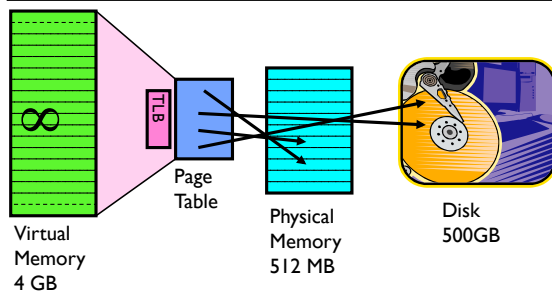

- Principle: **Transparent Level of Indirection** (page table)
 - Supports flexible placement of physical data
 - » Data could be on disk or somewhere across network
 - Variable location of data transparent to user program
 - » Performance issue, not correctness issue

11/11/17

CS162 @UCB Fall 17

Lec 14.27

Since Demand Paging is Caching, Must Ask...

- What is block size?
 - 1 page
- What is organization of this cache (i.e. direct-mapped, set-associative, fully-associative)?
 - Fully associative: arbitrary virtual \rightarrow physical mapping
- How do we find a page in the cache when look for it?
 - First check TLB, then page-table traversal
- What is page replacement policy? (i.e. LRU, Random...)
 - This requires more explanation... (kinda LRU)
- What happens on a miss?
 - Go to lower level to fill miss (i.e. disk)
- What happens on a write? (write-through, write back)
 - Definitely write-back – need dirty bit!

11/11/17

CS162 @UCB Fall 17

Lec 14.28

Recall: What is in a Page Table Entry

- What is in a Page Table Entry (or PTE)?
 - Pointer to next-level page table or to actual page
 - Permission bits: valid, read-only, read-write, write-only
- Example: Intel x86 architecture PTE:
 - Address same format previous slide (10, 10, 12-bit offset)
 - Intermediate page tables called “Directories”

Page Frame Number (Physical Page Number)	Free (OS)	0	L	D	A	PCD	PWT	U	W	P
31-12	11-9	8	7	6	5	4	3	2	1	0

- P: Present (same as “valid” bit in other architectures)
- W: Writeable
- U: User accessible
- PWT: Page write transparent: external cache write-through
- PCD: Page cache disabled (page cannot be cached)
- A: Accessed: page has been accessed recently
- D: Dirty (PTE only): page has been modified recently
- L: L=1 ⇒ 4MB page (directory only).
Bottom 22 bits of virtual address serve as offset

11/11/17

CS162 @UCB Fall 17

Lec 14.29

Demand Paging Mechanisms

- PTE helps us implement demand paging
 - Valid ⇒ Page in memory, PTE points at physical page
 - Not Valid ⇒ Page not in memory; use info in PTE to find it on disk when necessary
- Suppose user references page with invalid PTE?
 - Memory Management Unit (MMU) traps to OS
 - » Resulting trap is a “Page Fault”
 - What does OS do on a Page Fault?:
 - » Choose an old page to replace
 - » If old page modified (“D=1”), write contents back to disk
 - » Change its PTE and any cached TLB to be invalid
 - » Load new page into memory from disk
 - » Update page table entry, invalidate TLB for new entry
 - » Continue thread from original faulting location
 - TLB for new page will be loaded when thread continued!
 - While pulling pages off disk for one process, OS runs another process from ready queue
 - » Suspended process sits on wait queue



11/11/17

CS162 @UCB Fall 17

Lec 14.30

Summary: Steps in Handling a Page Fault

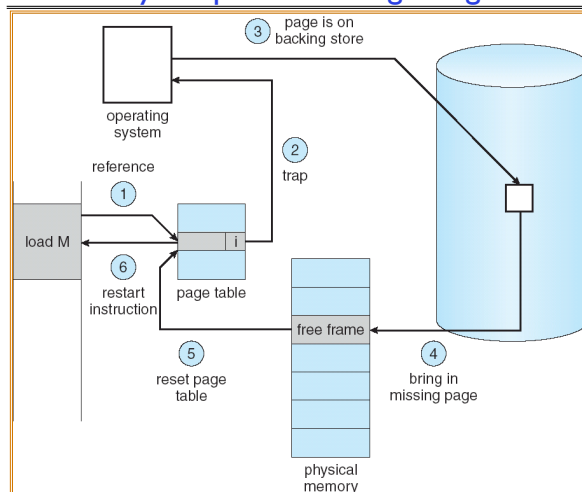

11/11/17

CS162 @UCB Fall 17

Lec 14.31

Summary

- A cache of translations called a “Translation Lookaside Buffer” (TLB)
 - Relatively small number of PTEs and optional process IDs (< 512)
 - Fully Associative (Since conflict misses expensive)
 - On TLB miss, page table must be traversed and if located PTE is invalid, cause Page Fault
 - On change in page table, TLB entries must be invalidated
 - TLB is logically in front of cache (need to overlap with cache access)
- Precise Exception specifies a single instruction for which:
 - All previous instructions have completed (committed state)
 - No following instructions nor actual instruction have started
- Can manage caches in hardware or software or both
 - Goal is highest hit rate, even if it means more complex cache management

11/11/17

CS162 @UCB Fall 17

Lec 14.32