

`inst.eecs.berkeley.edu/~cs61c`

## CS61C : Machine Structure

# Lecture 23 – Introduction to Synchronous Digital Systems (SDS) Switches, Transistors, Gates



Senior Lecturer SOE Dan Garcia

`www.cs.berkeley.edu/~ddgarcia`

**Password Ring? ⇒  
Google wants to  
“put an end to all  
passwords”; a small USB key (with  
code inside, not a password) that  
would provide credentials, also  
would work with mobile devices.**



[www.technologyreview.com/news/512051/google-wants-to-replace-all-your-passwords-with-a-ring](http://www.technologyreview.com/news/512051/google-wants-to-replace-all-your-passwords-with-a-ring)

# New-School Machine Structures (It's a bit more complicated!)

Software

Hardware

- **Parallel Requests**

Assigned to computer  
e.g., Search "Garcia"

- **Parallel Threads**

Assigned to core  
e.g., Lookup, Ads

- **Parallel Instructions**

>1 instruction @ one time  
e.g., 5 pipelined instructions

- **Parallel Data**

>1 data item @ one time  
e.g., Add of 4 pairs of words

- **Hardware descriptions**

All gates @ one time

*Harness  
Parallelism &  
Achieve High  
Performance*

Warehouse  
Scale  
Computer



Smart  
Phone

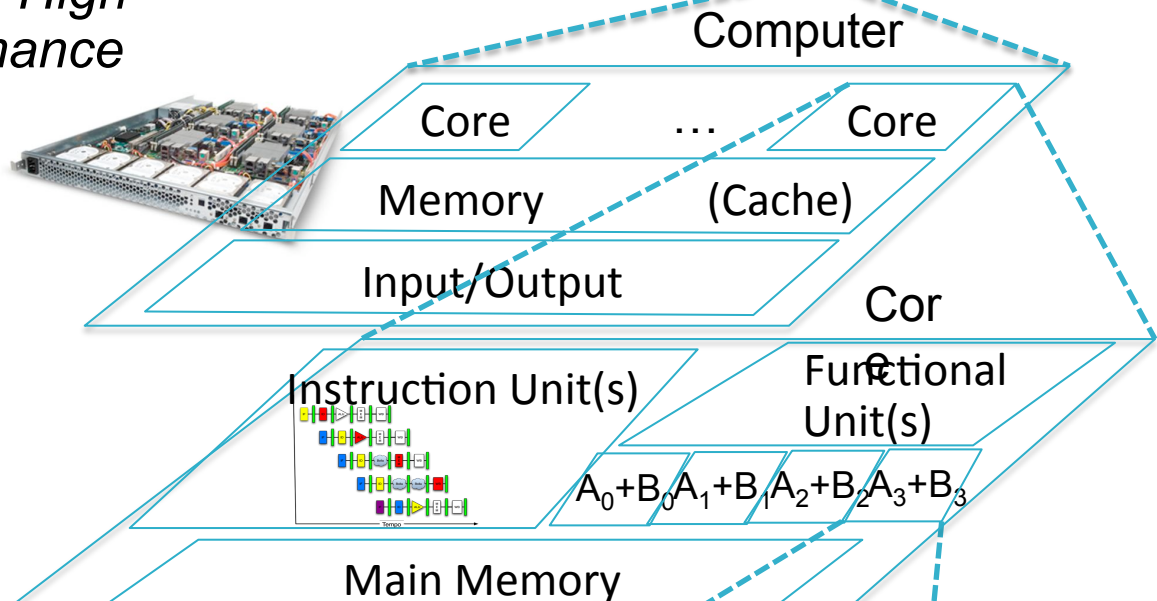

Today's Lecture

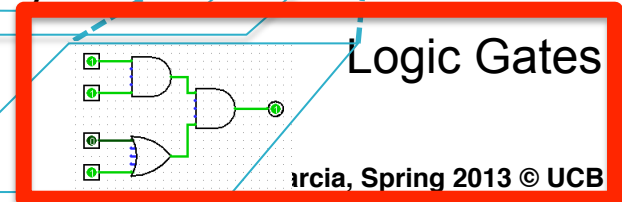

# What is Machine Structures?

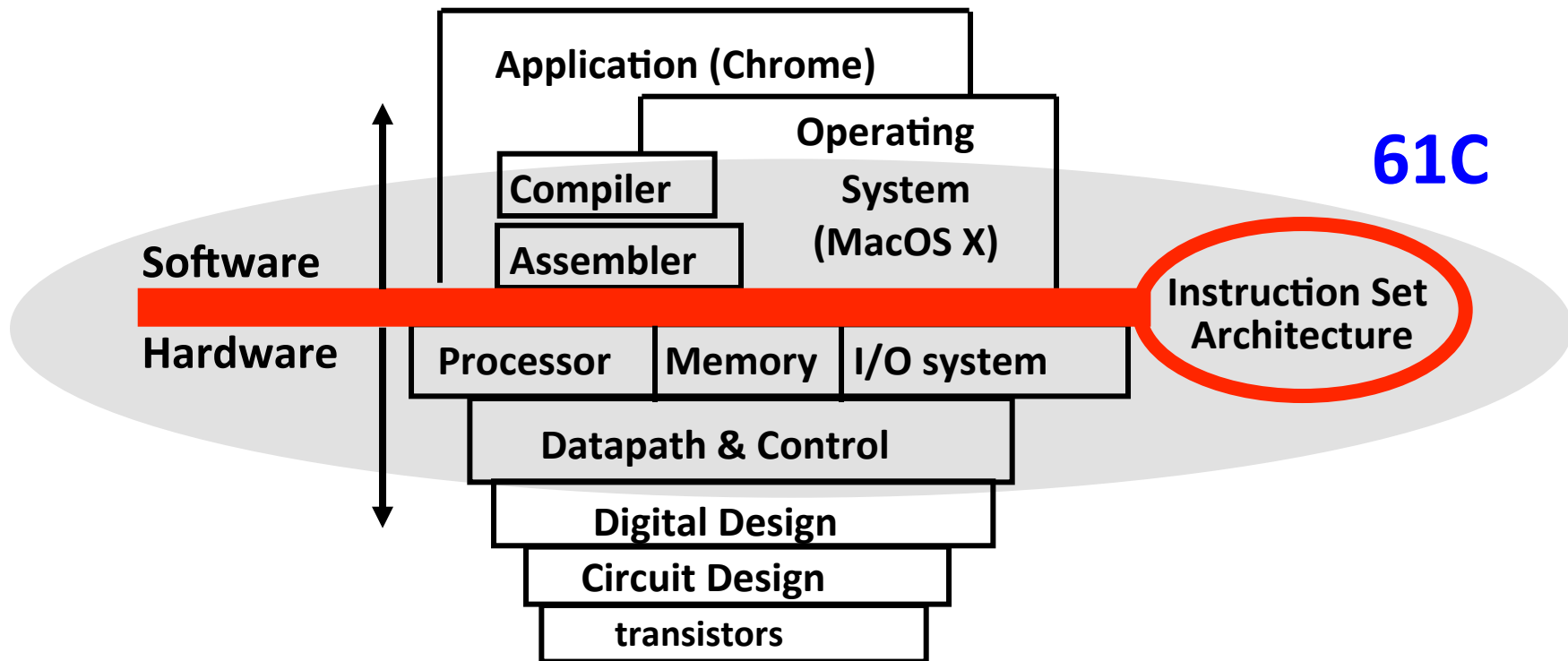

Coordination of many *levels of abstraction*  
ISA is an important abstraction level:  
contract between HW & SW



# Levels of Representation/ Interpretation

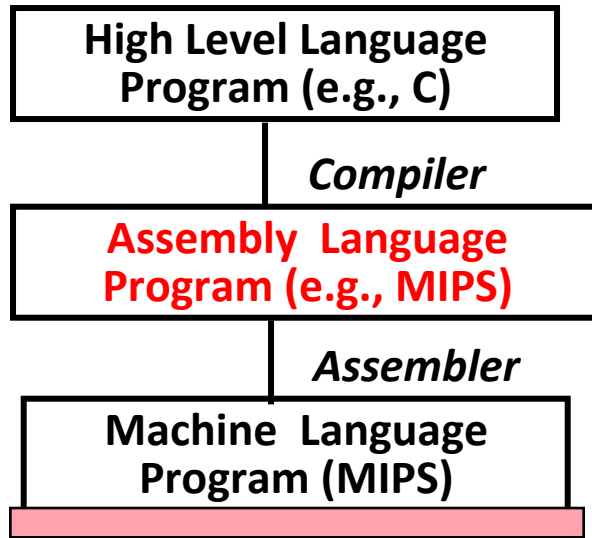

```
temp = v[k];
v[k] = v[k+1];
v[k+1] = temp;
```

```
lw    $t0, 0($2)
lw    $t1, 4($2)
sw    $t1, 0($2)
sw    $t0, 4($2)
```

Anything can be represented  
as a *number*,  
i.e., data or instructions

```
0000 1001 1100 0110 1010 1111 0101 1000
1010 1111 0101 1000 0000 1001 1100 0110
1100 0110 1010 1111 0101 1000 0000 1001
0101 1000 0000 1001 1100 0110 1010 1111
```

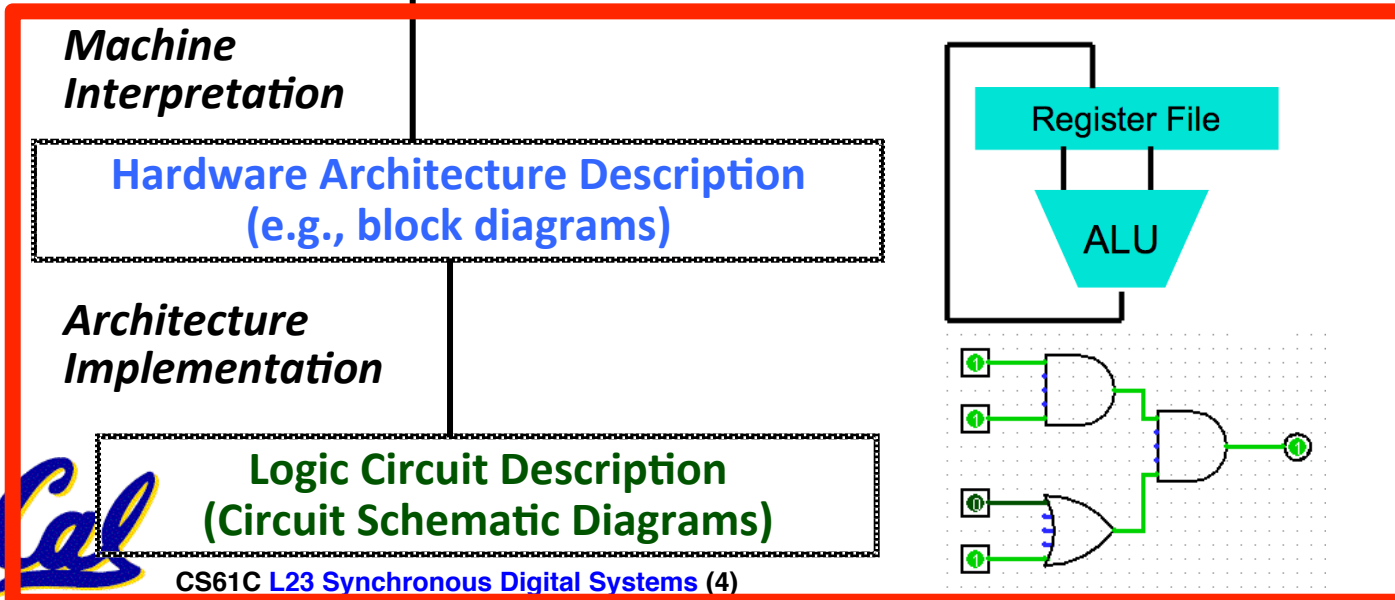

# Synchronous Digital Systems

*Hardware of a processor, such as the MIPS, is an example of a Synchronous Digital System*

## **Synchronous:**

- All operations coordinated by a central clock
  - “Heartbeat” of the system!

## **Digital:**

- All values represented by discrete values
- Electrical signals are treated as 1s and 0s; grouped together to form words



# Logic Design

- **Next several weeks: we'll study how a modern processor is built; starting with basic elements as building blocks**
- **Why study hardware design?**
  - Understand capabilities and limitations of hw in general and processors in particular
  - What processors can do fast and what they can't do fast (avoid slow things if you want your code to run fast!)
  - Background for more in depth hw courses (CS 150, CS 152)
  - There is just so much you can do with standard processors: you may need to design own custom hw for extra performance



# Switches: Basic Element of Physical Implementations

- Implementing a simple circuit (arrow shows action if wire changes to “1”):

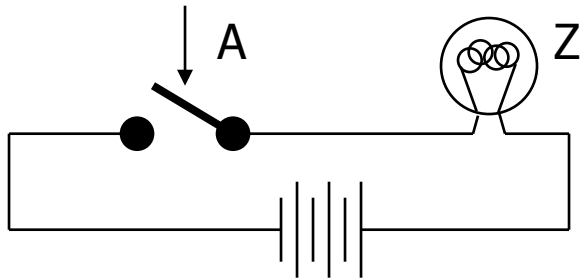

Close switch (if  $A$  is “1” or asserted) and turn on light bulb ( $Z$ )

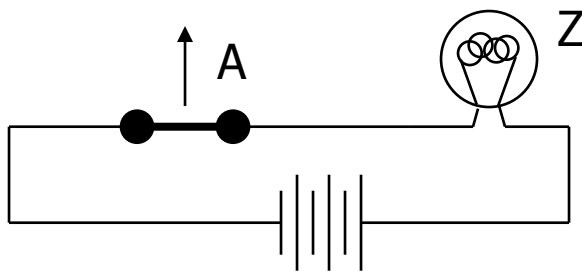

Open switch (if  $A$  is “0” or unasserted) and turn off light bulb ( $Z$ )

$$Z \equiv A$$

# Switches (cont' d)

- Compose switches into more complex ones (Boolean functions):

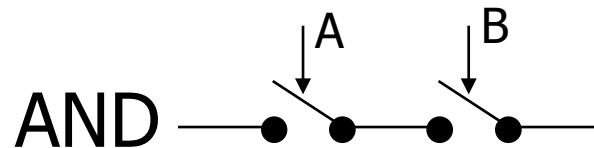

$$Z \equiv A \text{ and } B$$

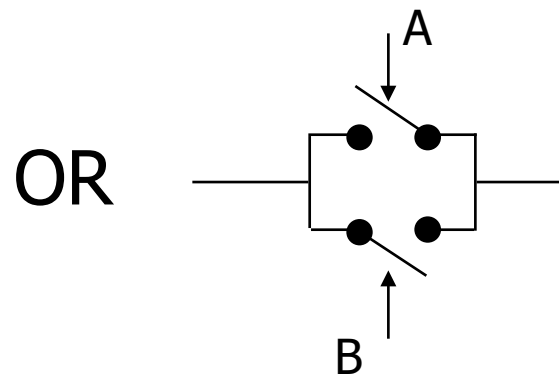

$$Z \equiv A \text{ or } B$$



# Transistor Networks

- **Modern digital systems designed in CMOS**
  - MOS: Metal-Oxide on Semiconductor
  - C for complementary: normally-open and normally-closed switches
- **MOS transistors act as voltage-controlled switches**



# <http://youtu.be/ZaBLiciesOU>

## MOS Transistors

- **Three terminals: drain, gate, and source**

- Switch action:

- if voltage on gate terminal is (some amount) higher/lower than source terminal then conducting path established between drain and source terminals

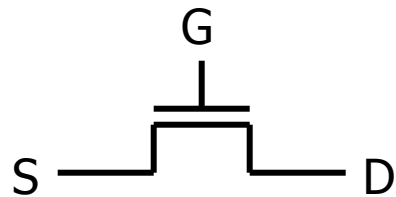

n-channel

open when voltage at G is low

closes when:

voltage(G) > voltage (S) +  $\epsilon$

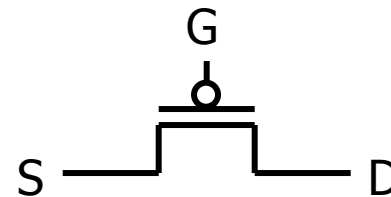

p-channel

closed when voltage at G is low

opens when:

voltage(G) < voltage (S) –  $\epsilon$



# MOS Networks

“1”  
(voltage source)

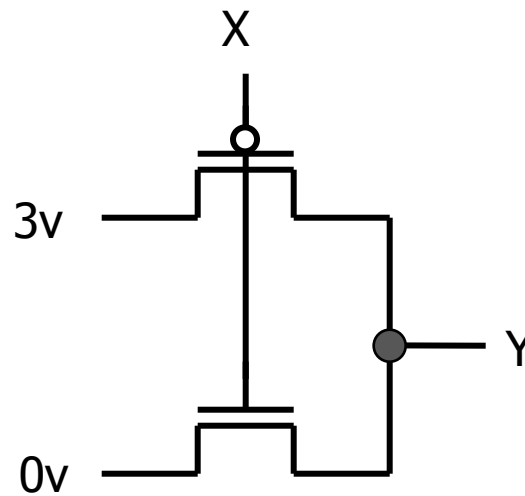

“0” (ground)

what is the relationship between x and y?

x	y
0 volts	
3 volts	



# Transistor Circuit Rep. vs. Block diagram

- Chips are composed of nothing but transistors and wires.
- Small groups of transistors form useful building blocks.

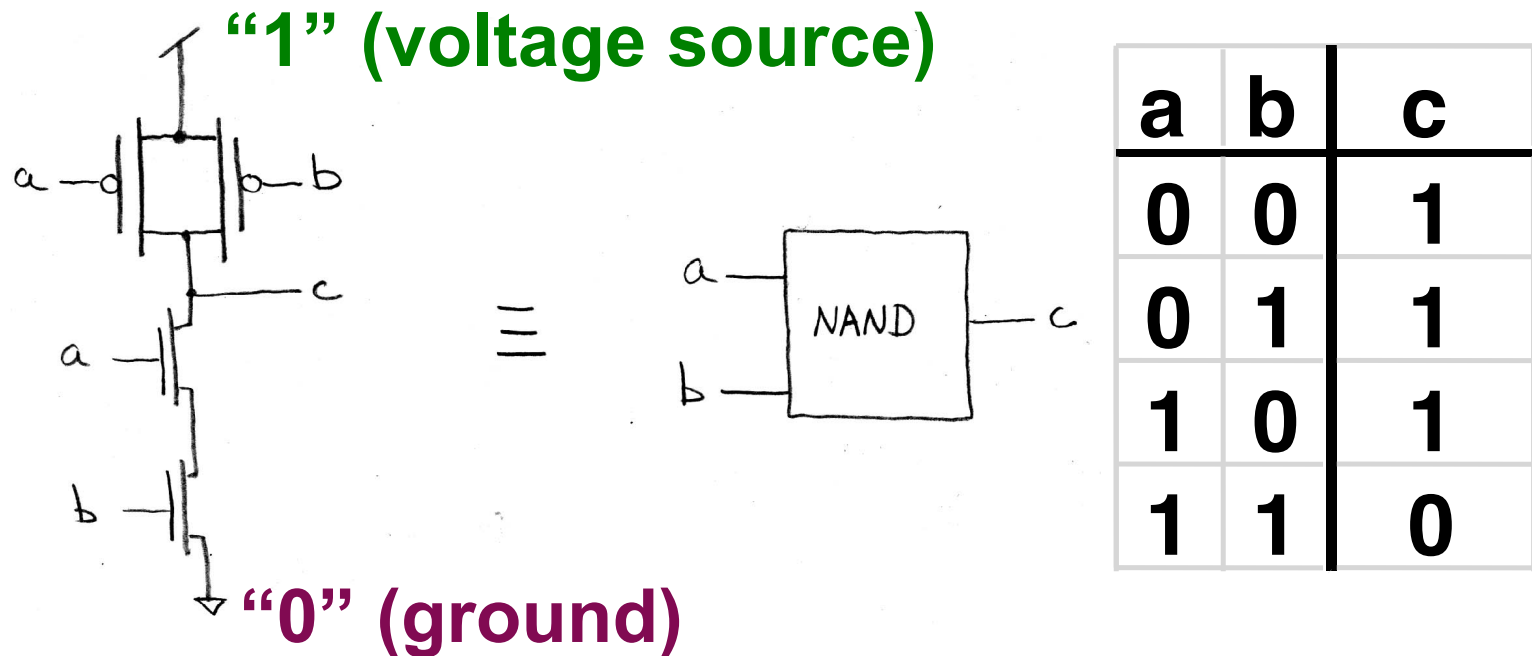

- Block are organized in a hierarchy to build higher-level blocks: ex: adders.

**(You can build AND, OR, NOT out of NAND!)**

# How many hours $h$ on Project 2a?

---



a)  $0 \leq h < 5$

b)  $5 \leq h < 10$

c)  $10 \leq h < 15$

d)  $15 \leq h < 20$

e)  $20 \leq h$

Other administrivia?



# Signals and Waveforms: Clocks

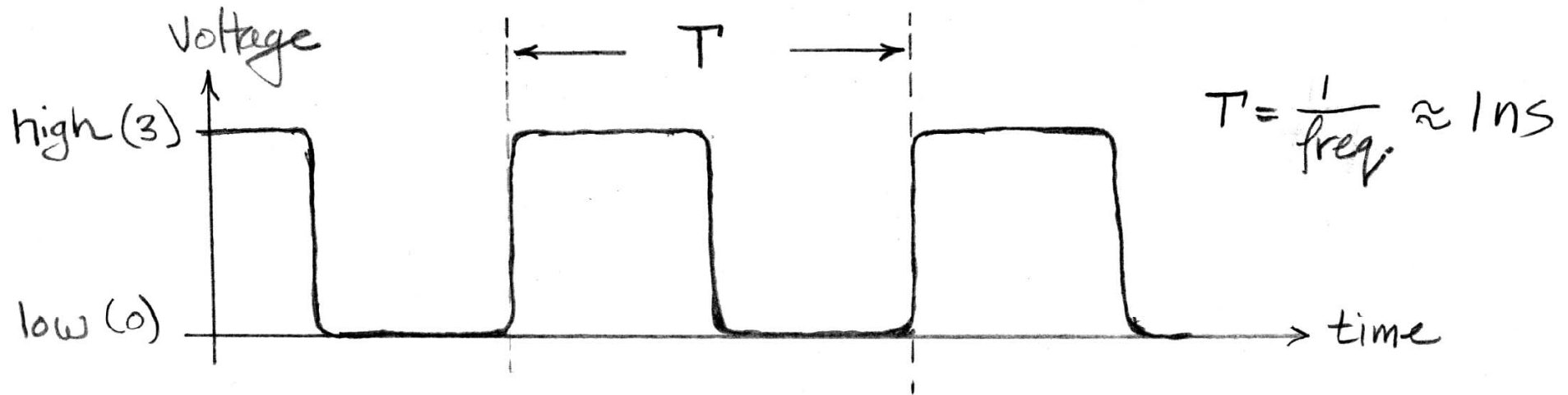

## • Signals

- When **digital** is only treated as 1 or 0
- Is transmitted over wires continuously
- Transmission is effectively instant
  - Implies that any wire only contains 1 value at a time

# Signals and Waveforms

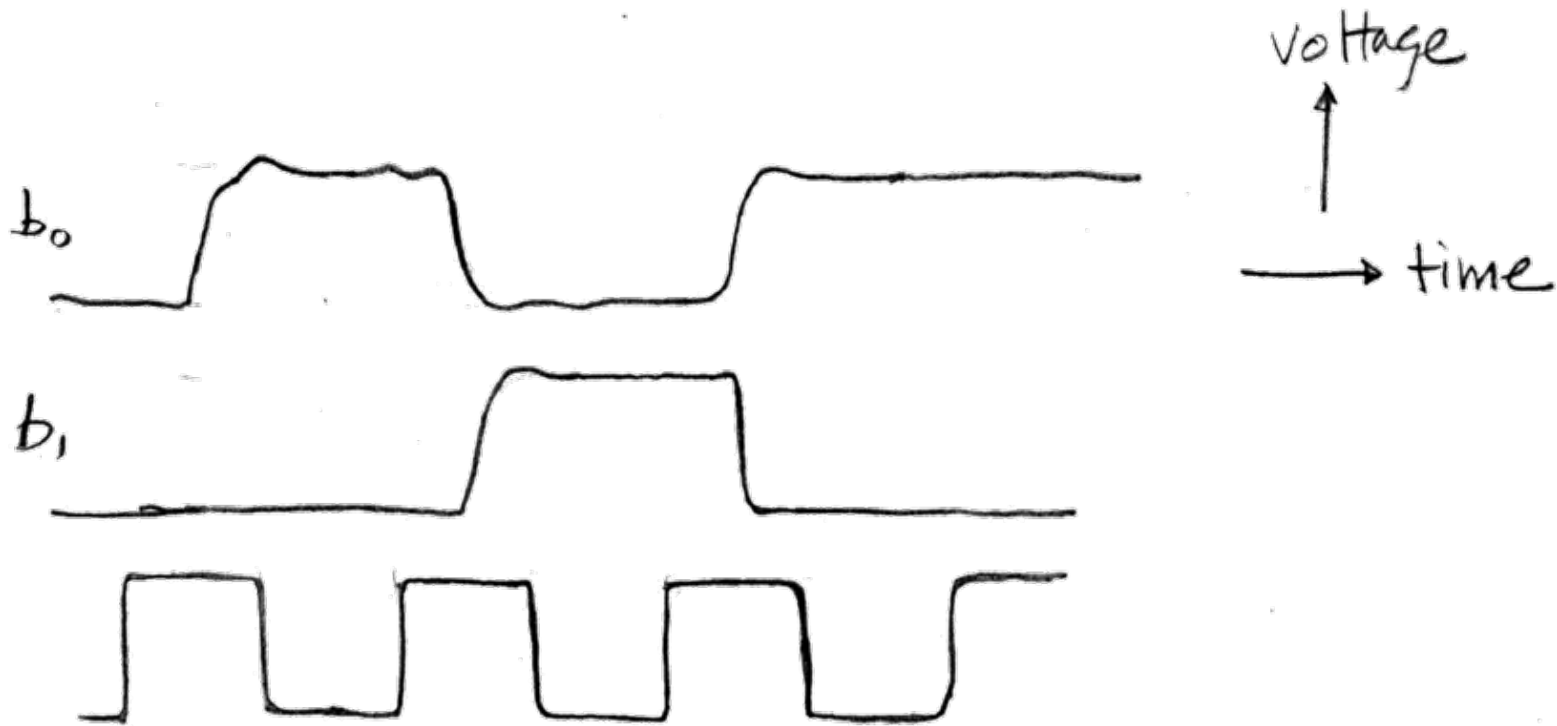
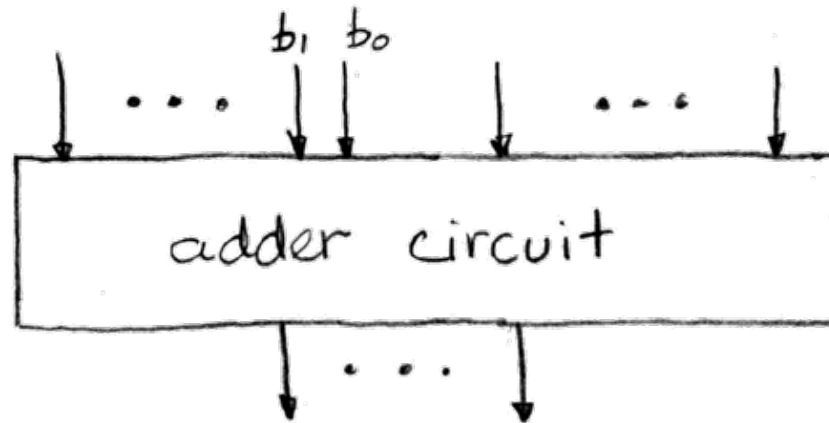

# Signals and Waveforms: Grouping

$x_3$   $x_2$   $x_1$   $x_0$   
↓ ↓ ↓ ↓

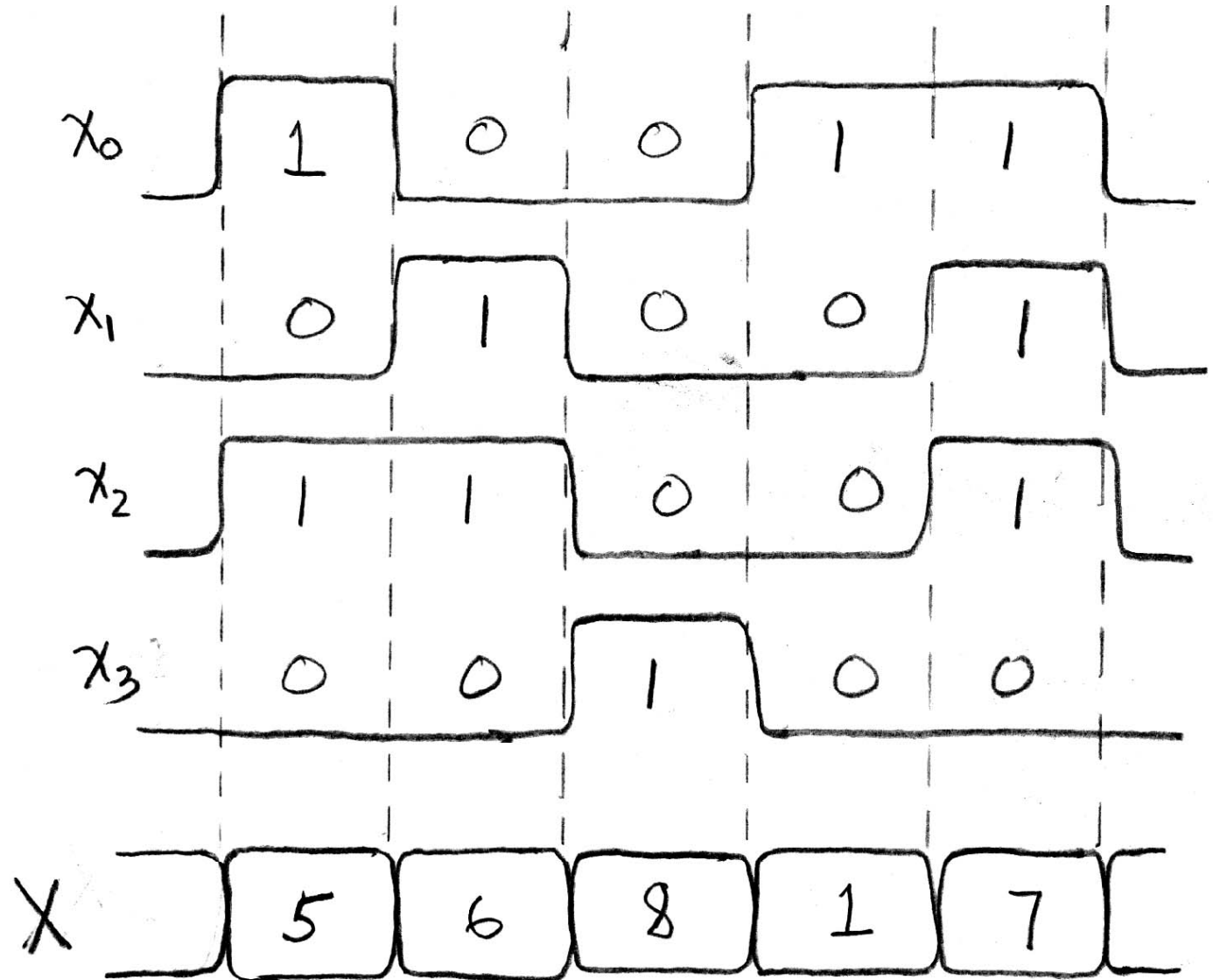



# Signals and Waveforms: Circuit Delay

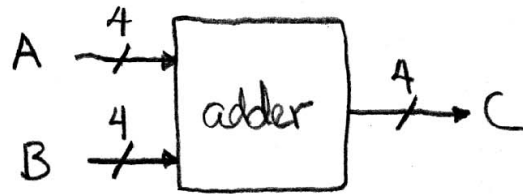

$$A = [a_3, a_2, a_1, a_0]$$

$$B = [b_3, b_2, b_1, b_0]$$

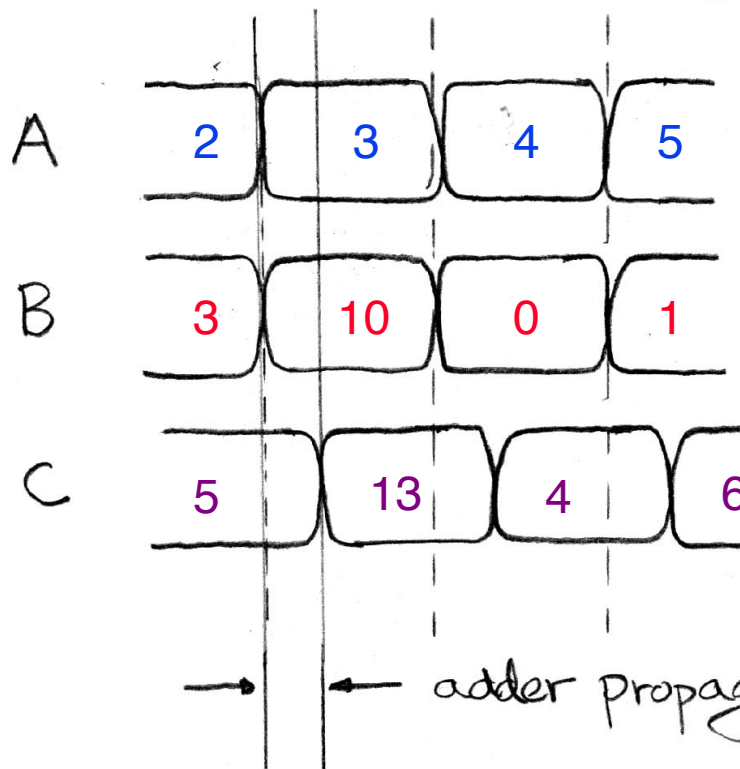
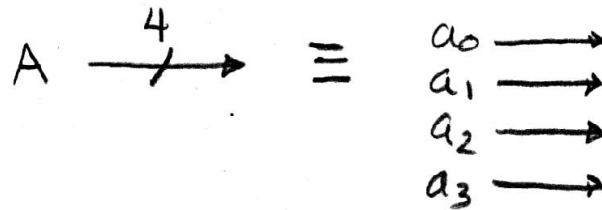

→ ← adder propagation delay



# Sample Debugging Waveform

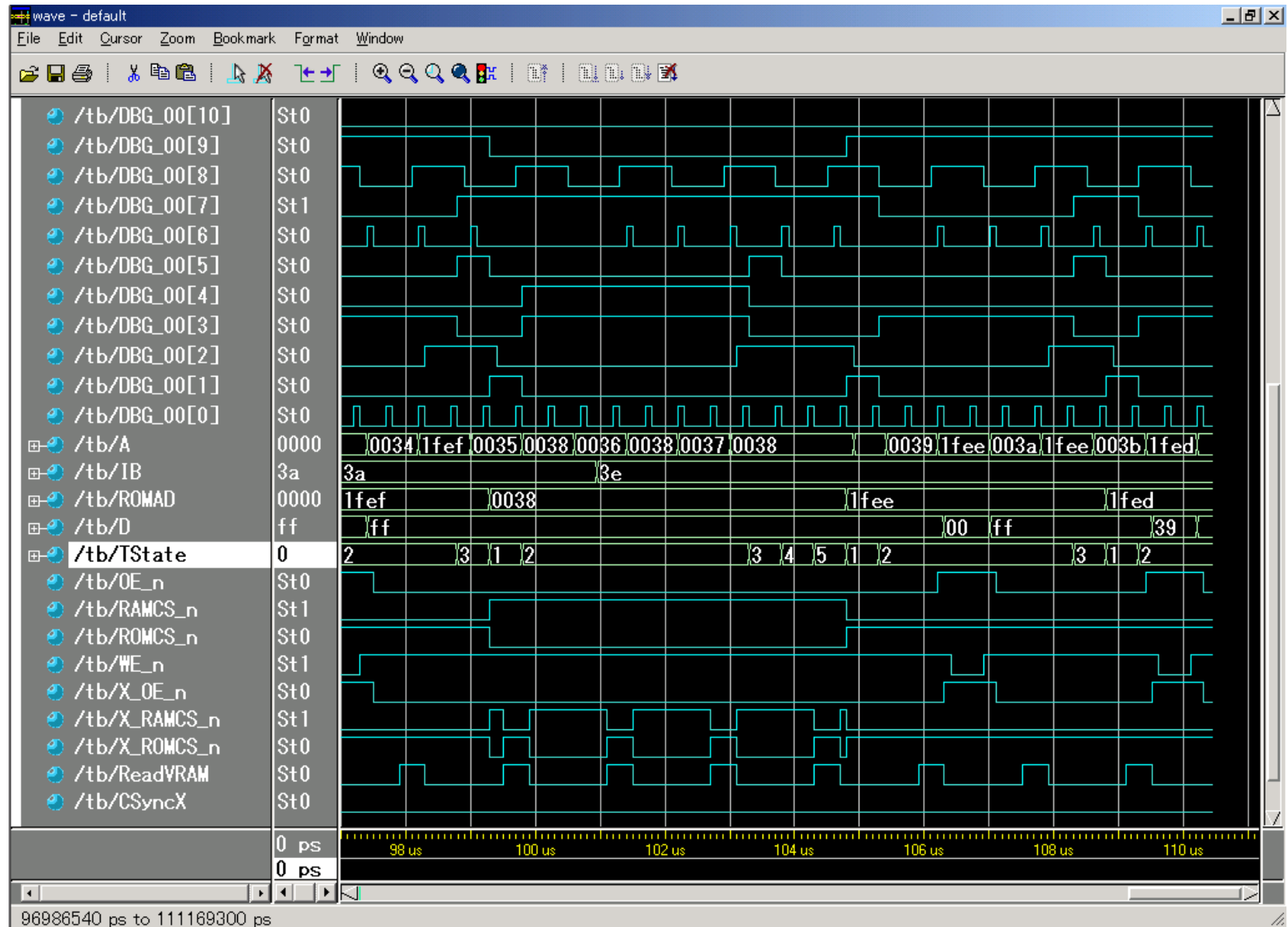

# Type of Circuits

---

- **Synchronous Digital Systems are made up of two basic types of circuits:**
- **Combinational Logic (CL) circuits**
  - Our previous adder circuit is an example.
  - **Output is a function of the inputs only.**
  - **Similar to a pure function in mathematics,  $y = f(x)$ . (No way to store information from one invocation to the next. No side effects)**
- **State Elements: circuits that store information.**



# Circuits with STATE (e.g., register)

---

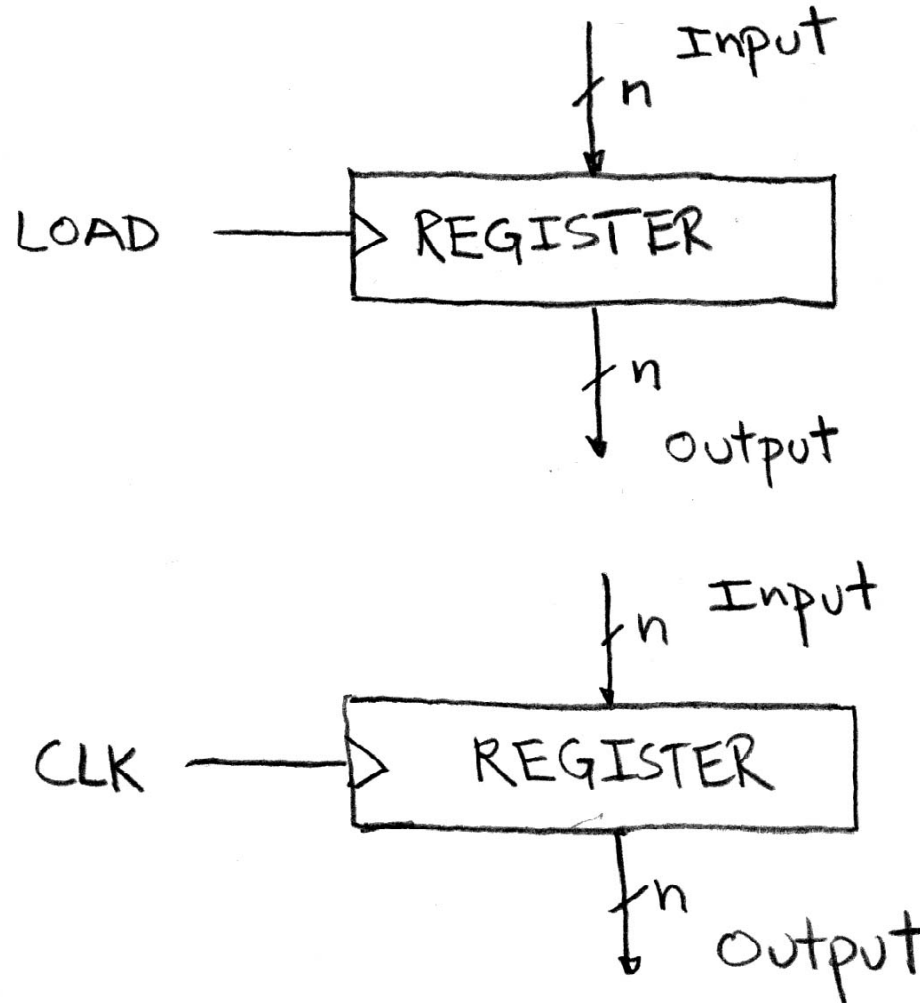

# Peer Instruction

---

- 1) SW **can peek** at HW (past ISA abstraction boundary) for optimizations
- 2) SW **can depend** on particular HW implementation of ISA

	12
a)	<b>FF</b>
b)	<b>FT</b>
c)	<b>TF</b>
d)	<b>TT</b>



# Design Hierarchy

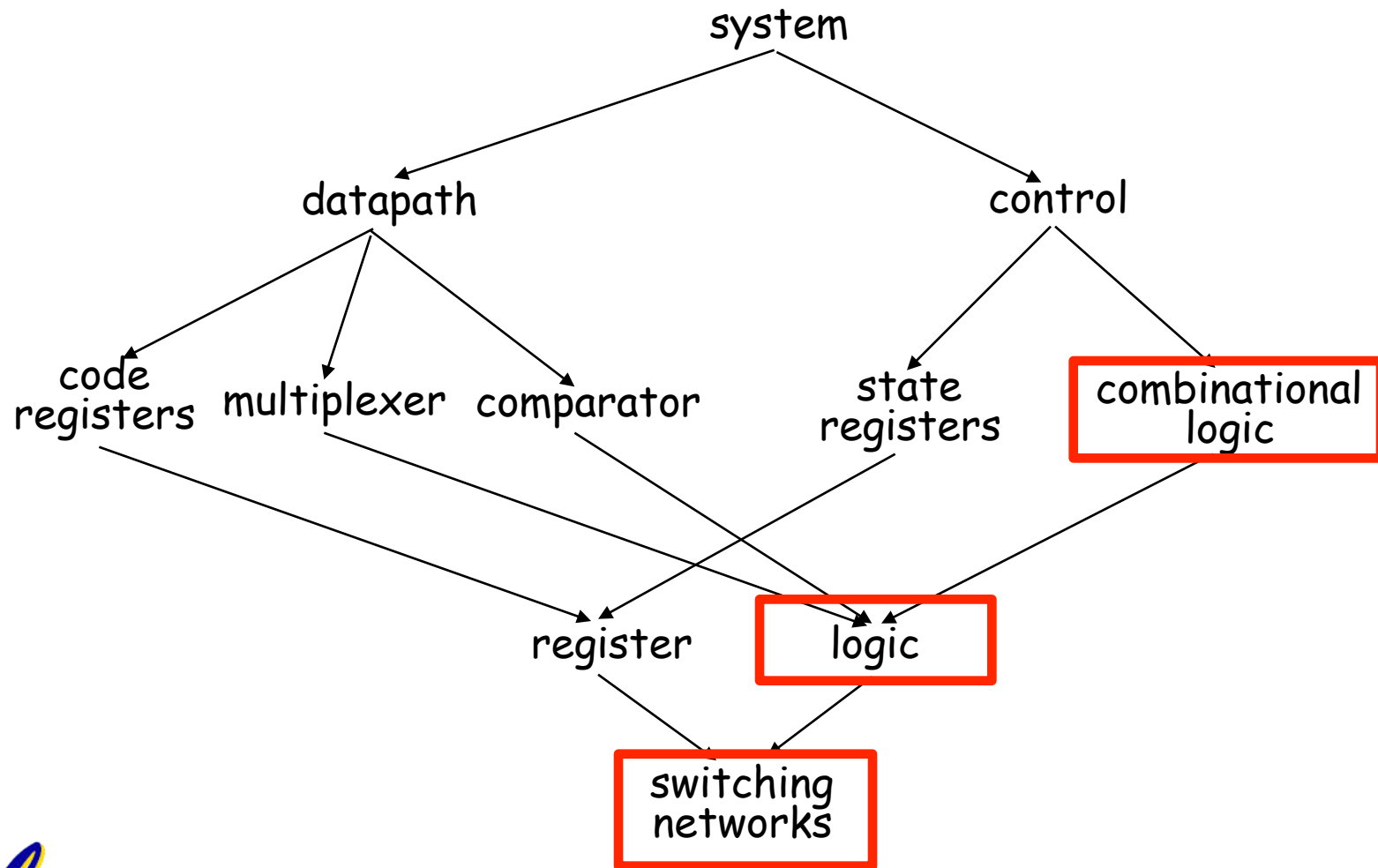

## And in conclusion...

---

- **ISA is very important abstraction layer**
  - **Contract between HW and SW**
- **Clocks control pulse of our circuits**
- **Voltages are analog, quantized to 0/1**
- **Circuit delays are fact of life**
- **Two types of circuits:**
  - **Stateless Combinational Logic (&,!,~)**
  - **State circuits (e.g., registers)**

