

Lecture 6

- Last time:
 - Rapid sketching techniques for more complicated transfer functions
- Today :
 - 2nd order circuits in the time and frequency domains

A Second Order System

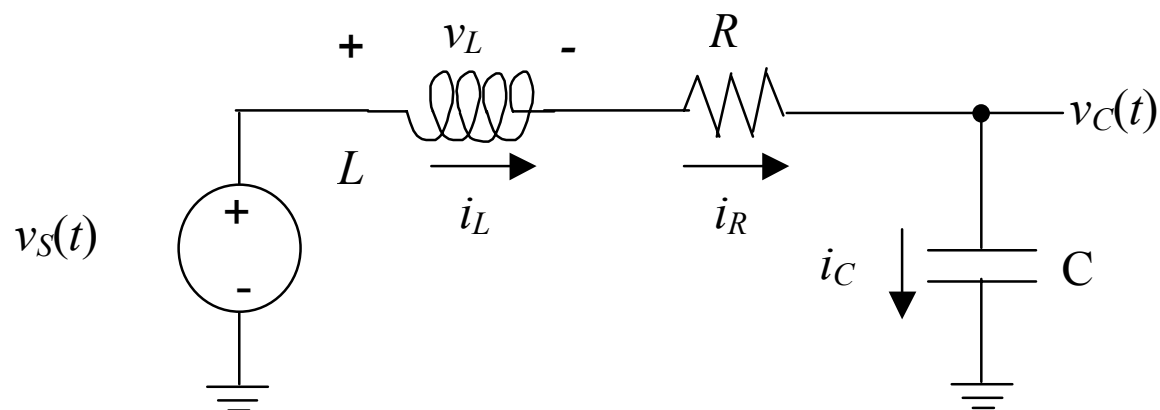

Where does the inductor come from?

Do step response: $v_S(t)$ jumps to V_{DD} at $t = 0$

Step Response of L-R-C Circuit

Initial conditions: $v_C(t=0) = 0$ V; $i_L(t=0) = 0$ A

$$i_L = i_C \longrightarrow \left(\frac{1}{L}\right) \int_0^t v_L(t') dt' = C \frac{dv_C}{dt}$$

$$\text{Inductor voltage: } v_L = V_{DD} - \left(\left(C \frac{dv_C}{dt} \right) R + v_C \right)$$

Solving the 2nd Order ODE

$$LC \frac{d^2 v_C}{dt^2} + RC \frac{dv_C}{dt} + v_C = V_{DD}$$

Steady-state solution: $v_{C,ss} = V_{DD}$ ($t \rightarrow \infty$)

Transient solution: $v_{C,tr} = ?$... guess $v_{C,tr} = ae^{st}$

and substitute: $LCs^2(ae^{st}) + RCs(ae^{st}) + ae^{st} = 0$

$$s^2 + (L/R)s + (1/(LC)) = 0$$

Characteristic Equation

$$s^2 + (L/R)s + (1/(LC)) = 0$$

Use quadratic formula to find the roots:

$$s_{1,2} = -\left(\frac{L}{2R}\right) \pm \sqrt{\left(\frac{L}{2R}\right)^2 - \left(\frac{1}{LC}\right)}$$

Underdamped Case

$$s_{1,2} = -\left(\frac{R}{2L}\right) \pm \sqrt{\left(\frac{R}{2L}\right)^2 - \left(\frac{1}{LC}\right)} = -\left(\frac{R}{2L}\right) \pm j\sqrt{\left(\frac{1}{LC}\right) - \left(\frac{R}{2L}\right)^2}$$

$$v_C(t) = V_{DD} + a_1 e^{-(R/2L)t} e^{j\sqrt{(1/LC) - (R/2L)^2}t} +$$

$$a_2 e^{-\underbrace{(R/2L)t}_{\alpha}} e^{-j\sqrt{\underbrace{(1/LC) - (R/2L)^2}_{\omega_d}}t}$$

Form of solution ...

Qualitative Underdamped Waveform

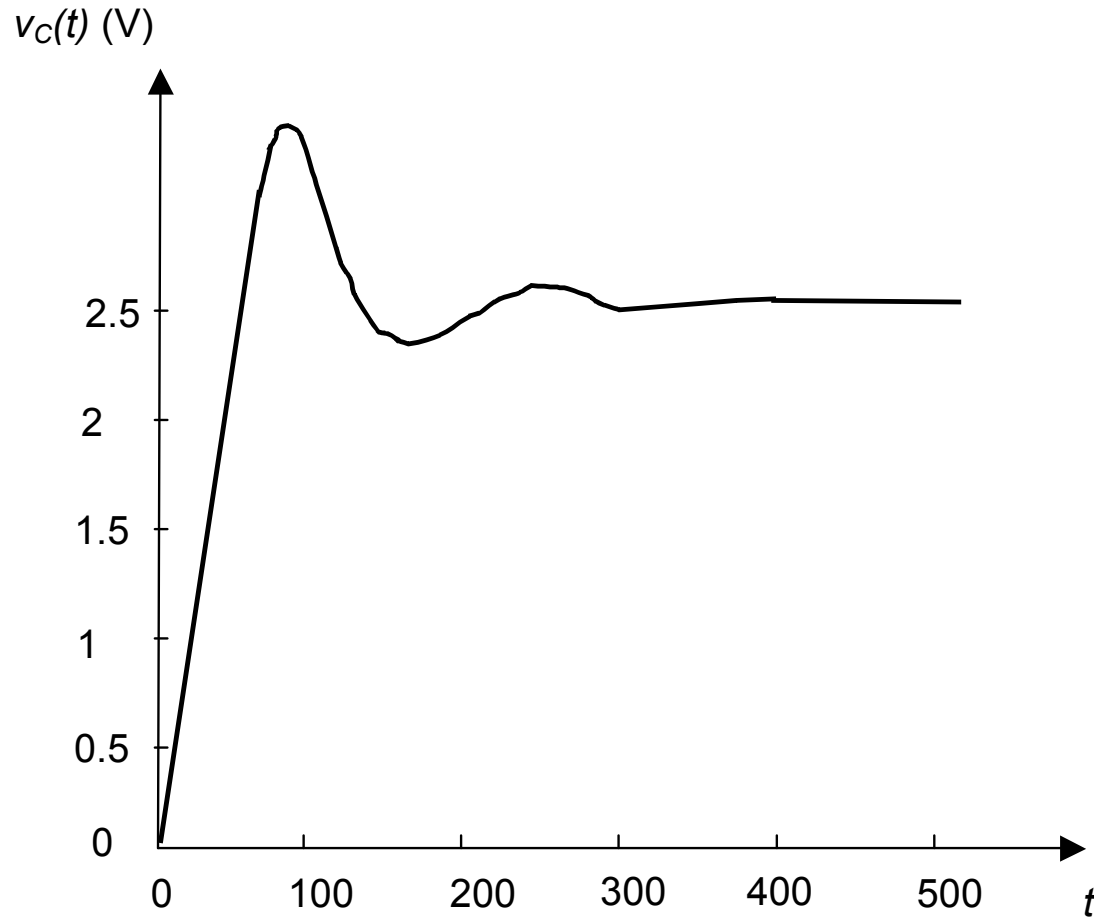

Extreme Underdamped Case

Exponential decay time is set by $\alpha = R/(2L)$

Small $R/L \rightarrow$ decay takes a long time and oscillation has a frequency that's nearly $\sqrt{1/(LC)}$

Number of cycles during “ringdown” is

$$N \approx \frac{(1/\alpha)}{(1/\sqrt{1/(LC)})} = \frac{2L/R}{\sqrt{LC}} = \frac{2}{R} \sqrt{\frac{L}{C}}$$

What happens when $R = 0 \Omega$?

thin-Film Bulk Acoustic Resonator (FBAR)

- Agilent Technologies

IEEE ISSCC 2001

2 GHz resonator

- $N > 1000$

- Brian Otis, Jan Rabaey (BWRC): low-noise oscillator

- Equivalent Circuit:

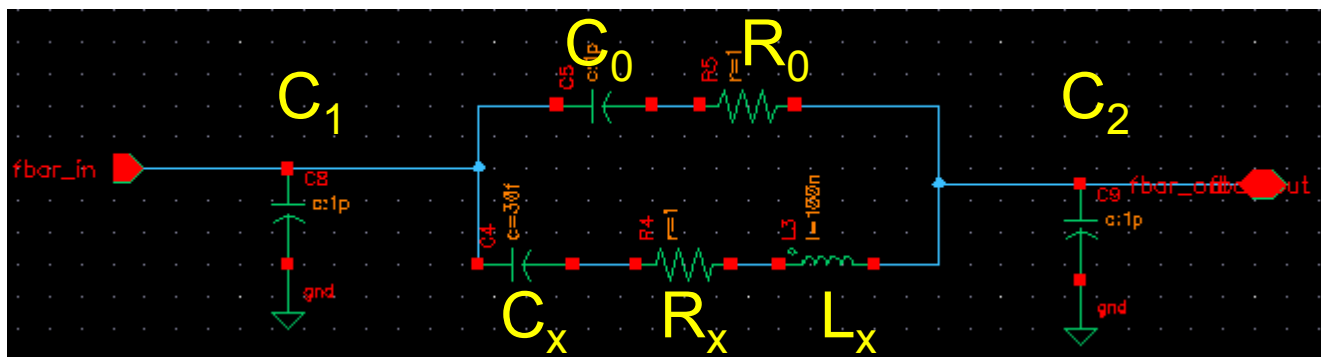

Drive Electrode

Thin Piezoelectric Film

Sense Electrode

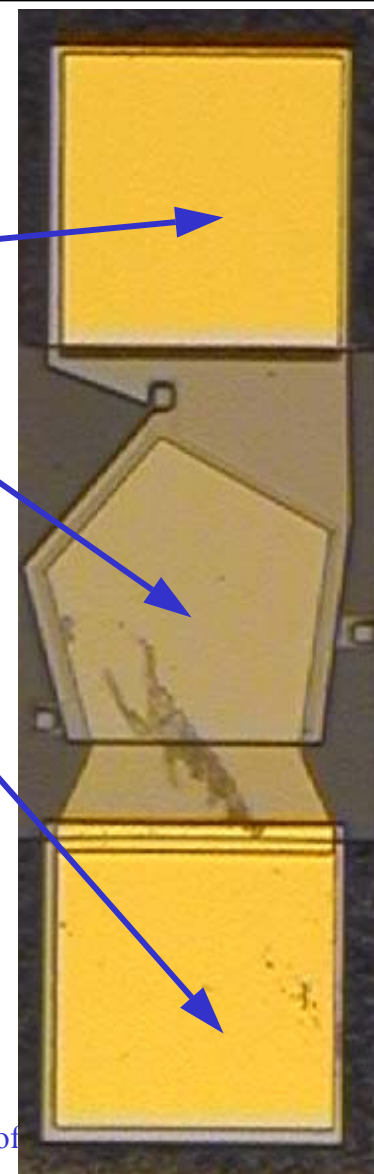

Phasor Analysis of 2nd Order Circuit

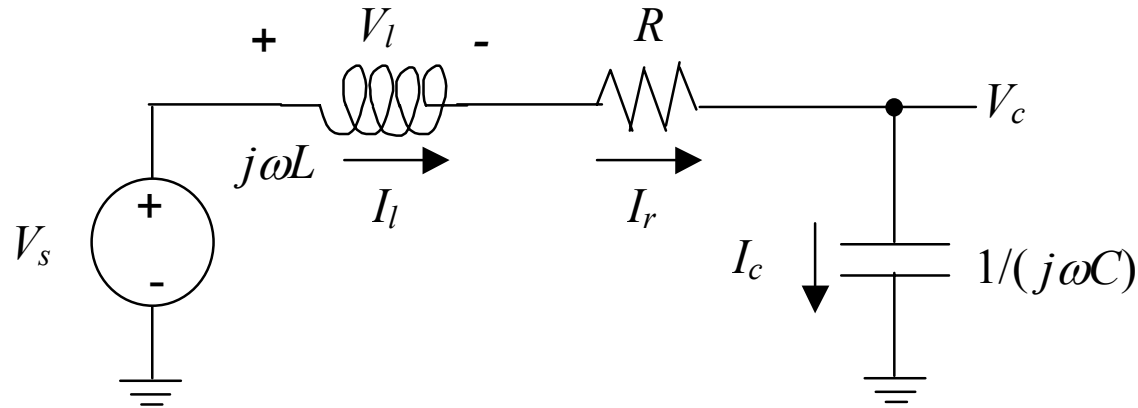

Impedance divider:

$$V_c = V_s \left[\frac{1/j\omega C}{(1/j\omega C) + R + (j\omega L)} \right]$$

Transfer Function

Simplifying:

$$H(j\omega) = \left[\frac{1}{1 + j\omega RC - \omega^2 LC} \right]$$

Define parameters: $\omega_o = 1/\sqrt{LC}$ $\tau = RC$

$$H(j\omega) = \left[\frac{1}{1 - (\omega/\omega_o)^2 + j\omega\tau} \right]$$

Limiting Cases: Magnitude and Phase

Low frequency: $\omega \ll \omega_o$

High frequency: $\omega \gg \omega_o$

Resonant frequency: $\omega = \omega_o$

Inductor-Capacitor “Tuning”

At resonance, the impedance of the capacitor cancels the impedance of the inductor \rightarrow phasor current is maximum and capacitor voltage peaks

How “sharp” or “narrow” is the resonance?

Define the quality factor $Q = \frac{\omega_o}{\Delta\omega} \longrightarrow Q = \frac{1}{\omega_o\tau}$

Magnitude Bode Plot

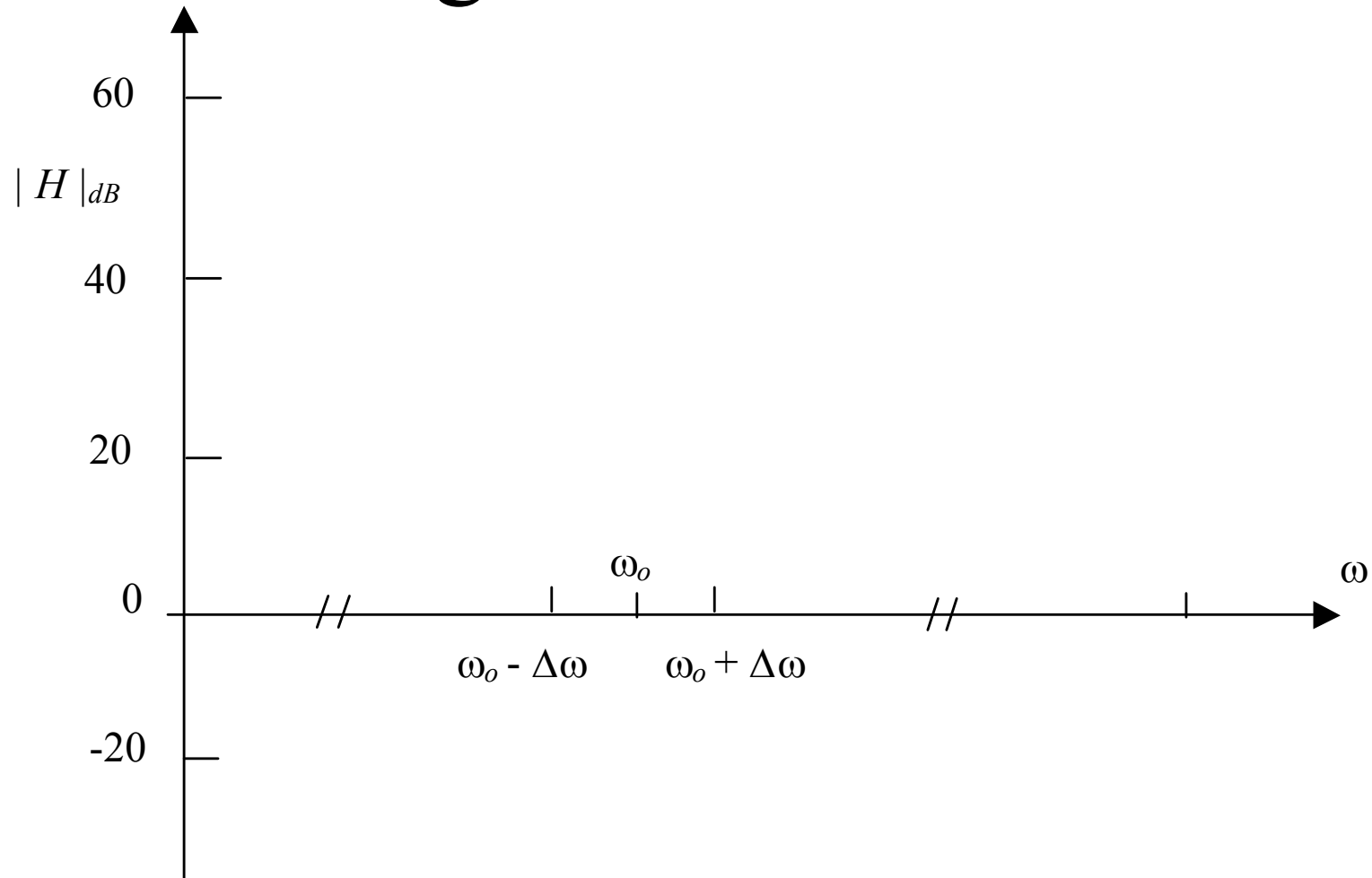

Phase Bode Plot

