

EE105 Lab Experiments

# Report 4: Single Stage BJT Amplifiers: Common Emitter

Name:

Lab Section:

## 1 Lab Questions

3.1.2 DC values and gain when biased at maximum gain:

$V_{IN} =$

$V_{OUT} =$

$A_v =$

3.1.3 Using a load line for the pull up resistor on a BJT I-V curve, explain why a BJT has very low gain if it is not biased in the forward active region.

3.2.1 What is the input resistance?

$R_{in} =$

3.2.2 What is the gain measured with the oscilloscope? Is the gain measured with the oscilloscope roughly the same as the gain you measured with ICS?

$A_v =$

3.2.3 Why does clipping happen at the top? Why does clipping happen at the bottom? What is the output voltage swing?

Output Voltage Swing =

3.2.4 Why is the capacitor needed when we attach the load?

3.2.5 What is the output resistance of the amplifier?

$R_{out} =$

3.3.2 DC values and gain biased at maximum gain:

$V_{IN} =$

$V_{OUT} =$

$A_v =$

Is the gain more or less than the gain found without the degenerating resistor? Give an explanation for what's going on in the circuit that causes this change in gain.

3.3.3 Measured amplifier parameters:

$R_{in} =$

$R_{out} =$

How are these values affected by the emitter degeneration resistor? Why?

3.3.4 Theoretical amplifier parameters:

$$R_{in} =$$

$$R_{out} =$$

$$A_v =$$

3.3.5 Why might emitter degeneration be useful?

3.5.1–4 Compare the loudness of the speaker for the two following cases: 10 mV, 1 kHz amplitude sine wave applied directly to speaker, and speaker placed on the output of the CE amplifier biased with a 1 k $\Omega$  resistor. Which is the loudest and why?

## 2 Post-Lab Questions

### 2.1 Amplifier Two-Port Model

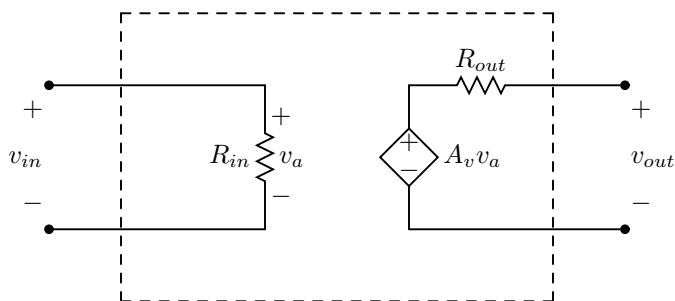

**Figure 1:** Generalized voltage amplifier

1. A CE amplifier can be represented as a generalized voltage amplifier shown in Figure 1, where  $R_{in}$ ,  $R_{out}$ , and  $A_v$  are the values you found for input resistance, output resistance, and voltage gain, respectively. This generalization was accomplished by applying the concept of a Thévenin equivalent circuit on its small signal model. Now suppose that  $v_{in}$  is an ideal source supplying a 1 kHz, 20 mV peak-to-peak sine wave. What is  $v_{out}$ ? Use the values obtained from the lab (no emitter degeneration, 10 k $\Omega$  biasing resistor) for  $R_{in}$ ,  $R_{out}$ , and  $A_v$ .

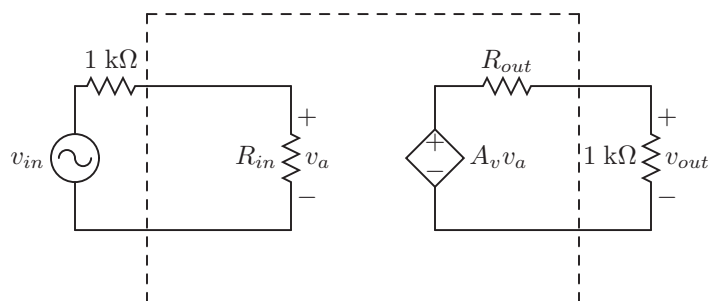

**Figure 2:** Voltage amplifier with non-ideal source and load attached

2. Now suppose a non-ideal voltage source with an internal source resistance of 1 k $\Omega$  was attached at  $v_{in}$ , and a load resistance of 1 k $\Omega$  was attached at the output as shown in Figure 2. If a 20 mV peak-to-peak sine wave was applied at the input, what would be the signal across the load?

