

UNIVERSITY OF CALIFORNIA
College of Engineering
Department of Electrical Engineering and Computer Sciences

HSPICE Tutorial

1. Objective

The objective of this session is to give initial exposure to the software environment that will be used in the lab session throughout the semester.

HSPICE (a circuit simulator) and WaveView Analyzer (a waveform viewer) will be used to execute some of the procedures that are necessary in many lab assignments, in addition to your project, during the course.

2. Set up the simulation environment

- a. Login the computer in Room353 using your WINDOWS instructional account. You may want to change the password using the command listed on the instructional account sheet for both WINDOWS and UNIX for future use. In our lab, we will use LINUX environment for running HSPICE.

Connect to a LINUX server:

Software PUTTY and Xming is used to connect to a LINUX server. First open the Xming software, then open PUTTY and type the server name “quasar.eecs.berkeley.edu” as the Host name. **Here remember to click SSH→X11 and enable X11 forwarding.**

You can also use other server such as “cory.eecs” or “pulsar.eecs” to run HSPICE.

Login using your instructional account:

After first time login, you can change the password using command: “ssh update” for UNIX account or CTRL+ALT+DEL then click change password for WINDOWS account.

- b. Copy the work files from the EE140 master account (which is ~ee140) to your home directory. You may want to do this as follows:

```
> mkdir LAB1 (to make a new directory named LAB1 or make it your own name)
```

```
> cd LAB1
```

```
> cp ~ee140/sp12/ee140.sp ./ (“ee140.sp” is the model file used in Lab1. Pay attention to the space between the “.” and “sp.” It is important for the command to work correctly.)
```

- c. Examine the model file by typing in the following:

```
> cat ee140.sp
```

The file (ee140.sp) contains the description of a level 4 CMOS transistor parameters to be performed by SPICE.

3. Run a sample inverter circuit

- Create and edit HSPICE file
Command: emacs CSamp.sp.
An editor will pop up into which you can type in the SPICE deck.
- A sample inverter circuit schematic is shown below with a sample spice deck (.sp file) that you may type in or directly copy to the emacs editor.

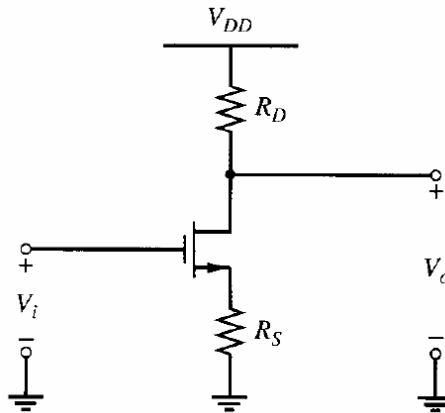

CSamp.sp:

```

***Simple CS Amplifier with Source Degeneration***

.lib 'ee140.sp' TT

**Begin Circuit Netlist**

**Power Supplies**

VDD vdd 0 5
VIN in 0 dc=1.2 ac=1

**Transistors**

M0 out in s 0 nmos L=0.1u W=10u

**Resistors**

Rd vdd out 10k
Rs s 0 1k

**Control Information**
.options post=2 nomod
.op

**AC Analysis**
.ac dec 1000 100 1e9

.END

```

There are three main sections in the spice deck:

- The netlist description. A netlist is a computer readable representation of the circuit schematic.
- The models used. A model in SPICE contains the parameters of the equations used by SPICE to analyze certain elements (such as transistors) in the circuit.
- The analysis to be performed during the simulation. We are requesting a transient analysis and a DC analysis of the circuit.

c. Simulate the circuit netlist.

```
> hspice CSamp.sp >! CSamp.out
```

Upon proper completion of the simulation, you should see the following:

```
> info:          ***** hspice job concluded
```

d. Definitions of the output files:

- CSamp.sp is the input netlist (your file)
- CSamp.sw0 is the DC sweep data output (used by awaves)
- CSamp.tr0 is the transient data output (used by awaves)
- CSamp.out is the output listing from HSPICE (look here for errors or text about the circuit)
- CSamp.st0 is the simulation run information (usually not useful)
- CSamp.ic0 is the information about the initial condition computed by HSPICE (usually don't need to look at this)

4. View the results of the transient analysis

Load WaveView Analyzer and examine the results of the transient analysis by entering the following:

```
> awaves &
```

or

```
> wv &
```

Once WaveView loads, click on **File/Import Waveform File**. This will open a menu to select which output file to display. Your output *CSamp.sw0* as well as *CSamp.tr0* should be listed; if not, switch to the correct directory using the tab or the arrows. Once you have found your output files, double-click on *CSamp.tr0*, which should import the transient data into **Output View** window.

To view the transient waveforms, click on the “+” sign in front of the file name “*D0:CSamp.tr0*” and then double click on “*oplevel*”. Now you should see the waveform data listed below. To see the waveform, you can just double click on the waveform name and it will appear in a new panel on the right. In our case, we want to plot the waveforms for **in** and **out** in the same panel. To do this, select **v(in)** by single clicking on it, then hold “Ctrl” and double click on **v(out)**. You should see both waveforms appear on the same panel.

Print the waveforms for **in** and **out**.

- View the results of the DC analysis.

Open a new panel for the DC waveform by clicking on **Panels/New/X-Y**. Click on **File/Import Waveform File** again to import *CSamp.sw0*. Then click on **v(out)** to print the output waveform in a new panel.

Print the waveform for **out**.

- Print waveform

Connect to the printer in 353 cory

Settings→printer and faxes→add a printer; Search name 353 and add the printer “**353 Cory HP Laser Jet 8150 DN Series PS on korchnoi**”

Print the waveform to file:

In WaveView, choose File→print→click “print to file” and give “file_name.ps” in the Output Path.

Using the following command to print

```
lpr -P print353-PS@korchnoi.eecs file_name.ps
```