

## *Inspection Analysis of Feedback Circuits*

### A. BACKGROUND

A feedback amplifier can be described in terms of the way the feedback network is connected to the basic amplifier. In particular, there are four basic feedback circuit topologies, and these are illustrated in Fig. 1. Note the following from Fig. 1:

- (1) With series feedback at the input, voltages  $v_i$  and  $v_{fb}$  are algebraically summed.
- (2) With shunt feedback at the input, currents  $i_i$  and  $i_{fb}$  are algebraically summed.
- (3) With series feedback at the output, a current  $i_o$  is sampled.
- (4) With shunt feedback at the output, a voltage  $v_o$  is sampled.

Included in Fig. 1 are simple examples of each feedback connection, implemented using bipolar transistors. Note the correspondence between each circuit schematic and its associated block diagram. To avoid cluttering, all biasing elements have been omitted from these circuits, but it is assumed that all transistors are biased in the forward-active region to yield a high gain basic amplifier in each case.

### B. STEP-BY-STEP PROCEDURE FOR ANALYZING FEEDBACK CIRCUITS

The following comprises a step-by-step procedure for analyzing a feedback amplifier circuit:

1. Identify the feedback topology:
  - (a) At the input: Is the feedback signal  $s_{fb}$  applied in series ( $v_{fb}$ ) or shunt ( $i_{fb}$ ) with the signal source  $s_i$ ?
  - (b) At the output: Is the sampled signal  $s_o$  obtained at the output node ( $v_o$ ) or from the output loop ( $i_o$ )?
2. Draw the basic amplifier circuit with feedback loading (and with the feedback set to zero):
  - (a) To determine the input loading by the feedback network:
    - (i) series sampling at the output: open-circuit the output loop to set  $i_o=0$
    - (ii) shunt sampling at the output: short-circuit the output node to set  $v_o=0$
  - (b) To determine the output loading by the feedback network:
    - (i) series summing at the input: open-circuit the input loop
    - (ii) shunt summing at the input: short-circuit the input nodes
3. Evaluate the open-loop gain function with feedback loading ( $a = \{a_v, a_i, r_m, \text{ or } g_m\}$ ).
4. Indicate  $s_{fb}$  and  $s_o$  and solve for the feedback factor ( $f = s_{fb}/s_o$ ).
5. From  $a$  and  $f$ , find  $T=af$ ,  $A = s_o/s_i$ ,  $R_i$ , and  $R_o$ .

Table 1 summarizes the equations and analysis techniques needed in the above procedure for each feedback configuration. In particular, the table succinctly summarizes the “shortings” and “openings” needed to determine feedback loading on the basic amplifier, the methods for determining the feedback, and equations/definitions for the feedback factor ( $f$ ), open-loop gain ( $a$ ), loop gain ( $T$ ), closed-loop gain ( $A$ ), input resistance ( $R_i$ ), and output resistance ( $R_o$ ).

SERIES-SHUNT:

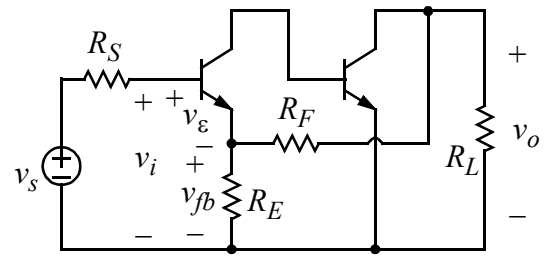
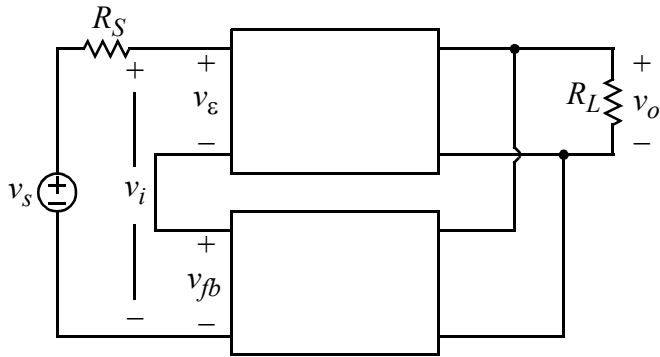

SHUNT-SERIES:

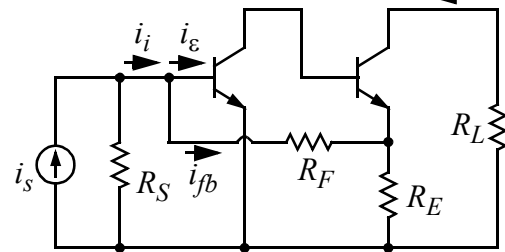
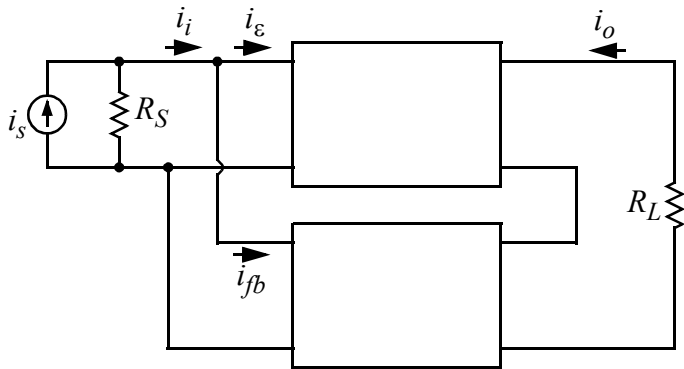

SERIES-SERIES:

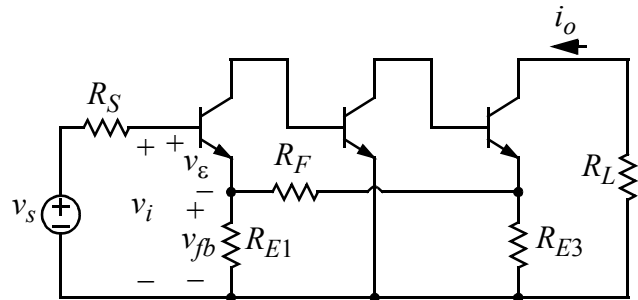
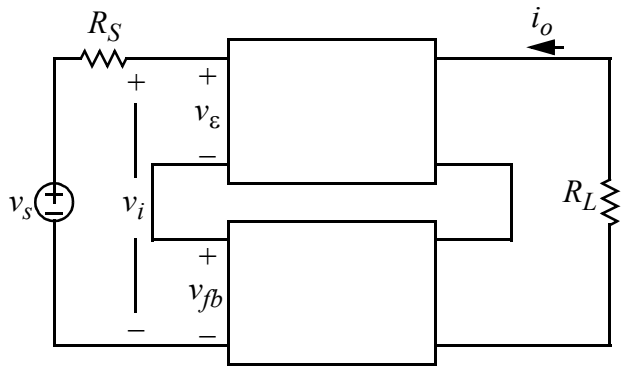

SHUNT-SHUNT:

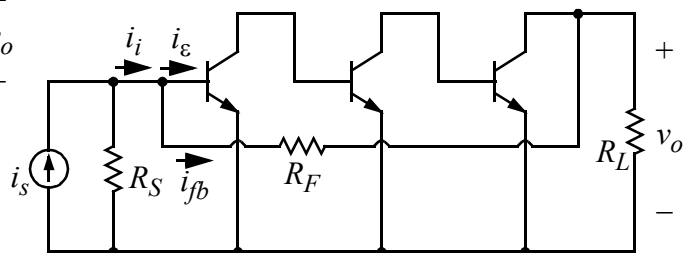
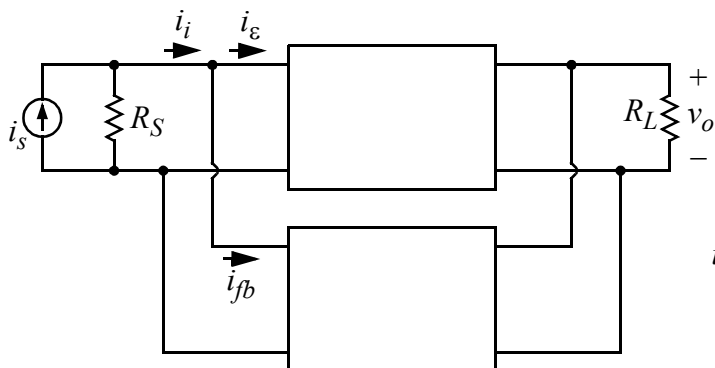

Fig. 1: The four feedback circuit topologies.

TABLE 1. Summary of Inspection Analysis Techniques and Formulas for Feedback Circuits

	Series-Shunt	Shunt-Series	Series-Series	Shunt-Shunt
To determine the feedback loading on the basic amplifier:				
At input	short output node	open output loop	open output loop	short output node
At output	open input loop	short input node	open input loop	short input node
To calculate the feedback factor:				
drive feedback network with a voltage and calculate the open-circuit voltage $v_{fb}$	drive feedback network with a current and calculate the short-circuit current $i_{fb}$	drive feedback network with a current and calculate the open-circuit voltage $v_{fb}$	drive feedback network with a voltage and calculate the short-circuit current $i_{fb}$	
Feedback Factor ( $f$ )	$v_{fb} / v_o$	$i_{fb} / i_o$	$v_{fb} / i_o$	$i_{fb} / v_o$
Open-Loop Gain ( $a$ )	$a_v = v_o / v_i$	$a_i = i_o / i_i$	$g_m = i_o / v_i$	$r_m = v_o / i_i$
Loop Gain ( $T$ )	$a_v f$	$a_i f$	$g_m f$	$r_m f$
Closed-Loop Gain ( $A$ )	$A_v = a_v / (1 + T)$	$A_i = a_i / (1 + T)$	$G_m = g_m / (1 + T)$	$R_m = r_m / (1 + T)$
Input Resistance ( $R_i$ )	$r_i (1 + T)$	$r_i / (1 + T)$	$r_i (1 + T)$	$r_i / (1 + T)$
Output Resistance ( $R_o$ )	$r_o / (1 + T)$	$r_o (1 + T)$	$r_o (1 + T)$	$r_o / (1 + T)$

Variable Glossary: $A_v, a_v$  = voltage-to-voltage gain $A_i, a_i$  = current-to-current gain $G_m, g_m$  = voltage-to-current gain (i.e., transconductance) $R_m, r_m$  = current-to-voltage gain (i.e., transresistance) $r_i$  = input resistance of the basic amplifier $r_o$  = output resistance of the basic amplifier $T$  = loop gain $f$  = feedback factor