

Factor	Bode Magnitude	Bode Phase
Constant K	$20 \log K$ 0 dB	$\pm 180^\circ$ if $K < 0$ 0° if $K > 0$
Zero @ Origin $(j\omega)^N$	slope = $20N$ dB/decade 0 dB	$(90N)^\circ$ 0°
Pole @ Origin $(j\omega)^{-N}$	slope = $-20N$ dB/decade 0 dB	$(-90N)^\circ$ 0°
Simple Zero $(1 + j\omega/\omega_c)^N$	slope = $20N$ dB/decade 0 dB	$(90N)^\circ$ 0°
Simple Pole $\left(\frac{1}{1 + j\omega/\omega_c}\right)^N$	slope = $-20N$ dB/decade 0 dB	$(-90N)^\circ$ 0°
Quadratic Zero $[1 + j2\xi\omega/\omega_c + (j\omega/\omega_c)^2]^N$	slope = $40N$ dB/decade 0 dB	$(180N)^\circ$ 0°
Quadratic Pole $\frac{1}{[1 + j2\xi\omega/\omega_c + (j\omega/\omega_c)^2]^N}$	slope = $-40N$ dB/decade 0 dB	$(-180N)^\circ$ 0°

Figure 1: Bode Plot Cheat Sheet

1. An RLC example

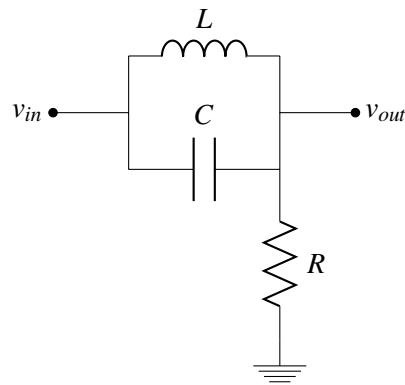

For the RLC filter above, with component values $R = 1 \text{ k}\Omega$, $C = 1 \text{ nF}$, and $L = 1 \text{ }\mu\text{H}$,

- Find the transfer function.
- Create a Bode plot of that transfer function.
- What important information is that Bode plot missing?

2. Factoring and Manipulating Transfer Functions

Make a Bode plot of the following more complicated transfer function:

$$H(s) = \frac{1}{10} \frac{((j\omega)^2 + 110j\omega + 1000)(j\omega + 10000)}{(j\omega + 1000)((j\omega)^2 + 101j\omega + 100)}$$