

# EECS192 Lecture 13

Apr. 19, 2016

## Notes:

1. Mon. 4/25: (430-530 pm) round 2 (NATCAR rules)
  1. 13 makes first turn
  2. 15 half track in < 5 minutes
  3. 18 whole track in less than 1 minute
  4. > 18 For cars which are fast and/or well-stabilized
2. Thanks for CalDay Sat. April 16 @ UCB
3. Safety
4. Oral reports-scheduling Th 4/28 (930-11?)  
Thurs 11-1230, 10-1230, 1-2 pm, 3-4, 4-530, 5-630 pm? Fri 9-10, 3-4,
5. Lab share Tues 5-7 pm, all of April. Also two benches
6. Quiz 5 result.

## Topics

- Digital Filtering
- Software Robustness- Observer
- Steering through Differential Braking
- Skid steering

# Digital Filtering

- Moving average
  - $y_1[n] = (y[n-2] + y[n-1] + y[n]) / 3$
- Median filter (outlier rejection)
- Notch filter (mechanical vibration)
  - $y[n] = (x[n-2] + 2x[n-1] + x[n]) / 4$
- Model based filtering (or Kalman filter)

(on board)

# Software Robustness: Observer

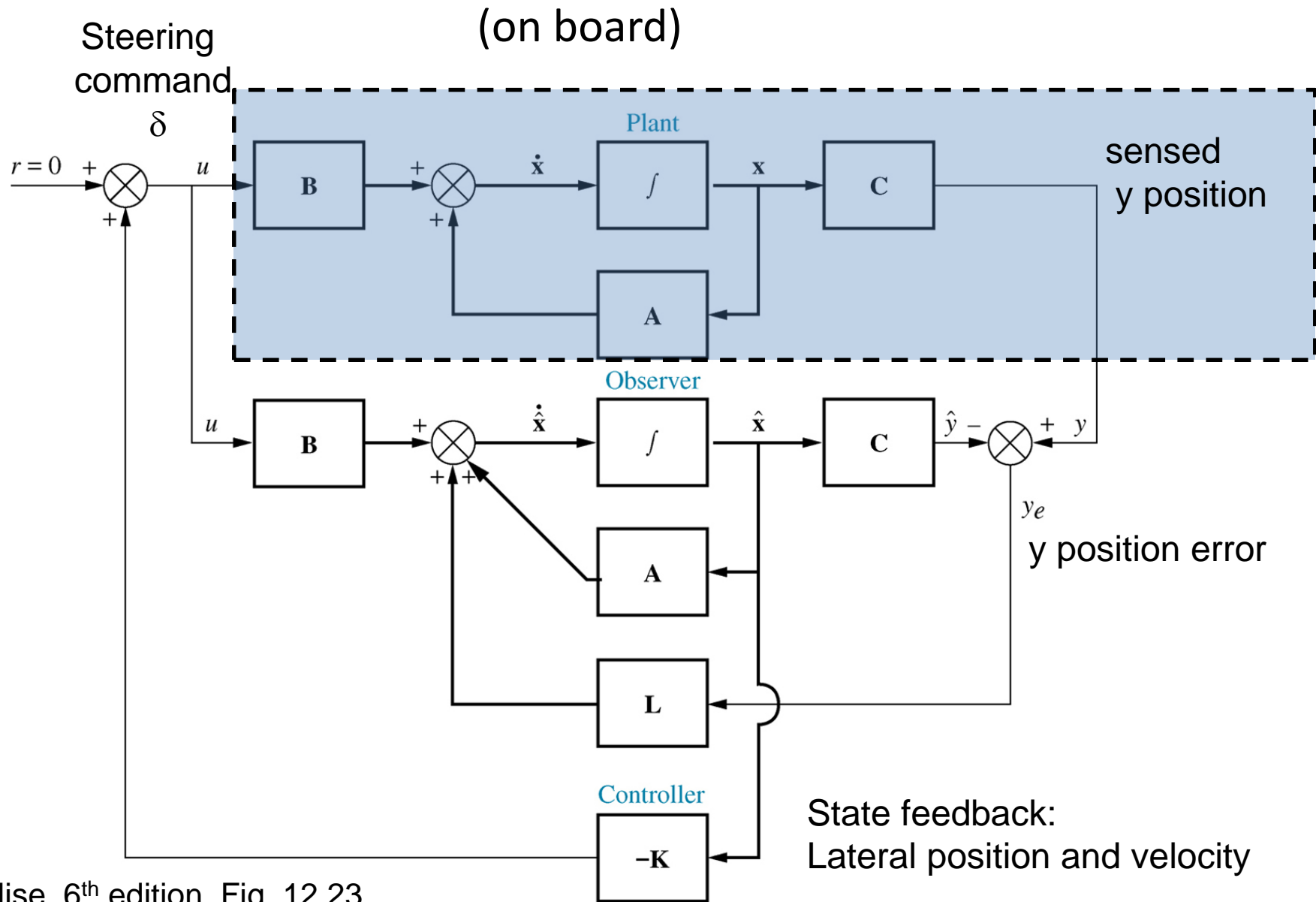

# Steering References (on web page)

- Vehicle Dynamics and Control During Abnormal Driving

<http://soliton.ae.gatech.edu/people/dcsl/research-abnormal.html>

Prof. Panagiotis Tsiotras, Georgia Tech

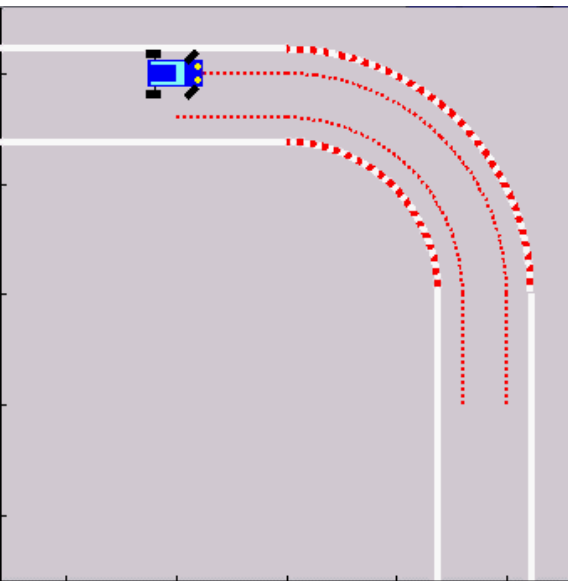

<http://soliton.ae.gatech.edu/people/dcsl/movies/skidding.avi>

<http://soliton.ae.gatech.edu/people/dcsl/movies/TrailBraking.avi>

# Steering References (on web page)

- Vehicle Dynamics and Control During Abnormal Driving (Georgia Tech)
- Velenis, E., Tsiotras, P., and Lu, J., "Aggressive Maneuvers on Loose Surfaces: Data Analysis and Input Parameterization," 15th IEEE Mediterranean Control Conference, June 26-29, Athens, Greece.
- Velenis, E., Tsiotras, P., and Lu, J., "Modeling Aggressive Maneuvers on Loose Surfaces: The Cases of Trail-Braking and Pendulum-Turn," European Control Conference, Kos, Greece, July 2-5, 2007.
- Some nice turning simulation (Georgia Tech): (video 1) (video 2)
- Baffet, G. Charara, A. Dherbomez, G. "An Observer of Tire Road Forces and Friction for Active Security Vehicle Systems" Mechatronics, IEEE/ASME Transactions on Publication Date: Dec. 2007 Volume: 12, Issue: 6 On page(s): 651-661
- Tseng, H.E. Ashrafi, B. Madau, D. Allen Brown, T. Recker, D. "The development of vehicle stability control at Ford" Mechatronics, IEEE/ASME Transactions on Publication Date: Sep 1999 Volume: 4, Issue: 3 On page(s): 223-234
- T. Pilutti, G. Ulsoy, and D. Hrovat, "Vehicle steering intervention through differential braking," Proc. American Control Conf. Seattle, Wash. June 1995.
- Brennan, S. Alleyne, A. "Using a scale testbed: Controller design and evaluation" Control Systems Magazine, IEEE Publication Date: Jun 2001 Volume: 21, Issue: 3 On page(s): 15-26
- Brennan, S. Alleyne, A. "The Illinois Roadway Simulator: a mechatronic testbed for vehicle dynamics and control," Mechatronics, IEEE/ASME Transactions on Publication Date: Dec 2000 Volume: 5, Issue: 4 On page(s): 349-359
- Chankyu Lee K. Hedrick Kyongsu Yi , "Real-time slip-based estimation of maximum tire-road friction coefficient," Mechatronics, IEEE/ASME Transactions on Publication Date: June 2004
- Han-Shue Tan; Guldner, J.; Patwardhan, S.; Chieh Chen; and others. Development of an automated steering vehicle based on roadway magnets-a case study of mechatronic system design. IEEE/ASME Transactions on Mechatronics, Sept. 1999, vol.4, (no.3):258-72.
- Guldner, J.; Sienel, W.; Han-Shue Tan; Ackermann, J.; and others. Robust automatic steering control for look-down reference systems with front and rear sensors. IEEE Transactions on Control Systems Technology, Jan. 1999, vol.7, (no.1):2-11.
- Patwardhan, S.; Han-Shue Tan; Guldner, J. A general framework for automatic steering control: system analysis. Proceedings of 16th American CONTROL Conference, Albuquerque, NM, USA, 4-6 June 1997). Evanston, IL, USA: American Autom. Control Council, 1997. p. 1598-602 vol.3.
- Patwardhan, S.; Han-Shue Tan; Guldner, J.; Tomizuka, M. Lane following during backward driving for front wheel steered vehicles. Proceedings of 16th American CONTROL Conference, Albuquerque, NM, USA, 4-6 June 1997). Evanston, IL, USA: American Autom. Control Council, 1997. p. 3348-53 vol.5.
- Guldner, J.; Han-Shue Tan; Patwardhan, S. Study of design directions for lateral vehicle control. Proceedings of the 36th IEEE Conference on Decision and Control, San Diego, CA, USA, 10-12 Dec. 1997). New York, NY, USA: IEEE, 1997. p. 4732-7 vol.5.
- Analysis of automatic steering control for highway vehicles with look-down lateral reference systems. Vehicle System Dynamics, Oct. 1996, vol.26, (no.4):243-69.

# Steering: Trail Braking Maneuver

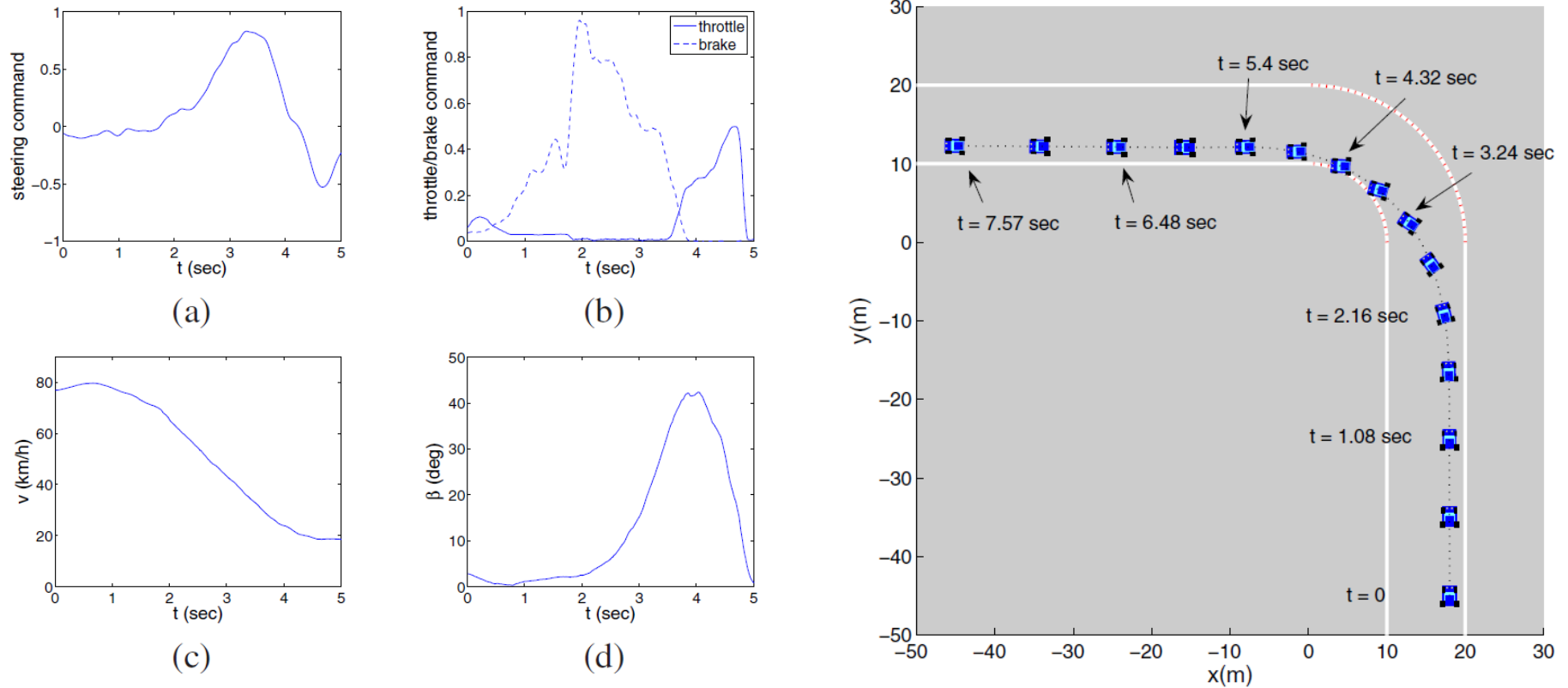

Fig. 3. Trail-Braking maneuver experimental data: (a) Normalized steering command; (b) Normalized throttle and braking commands; (c) Vehicle speed; (d) Vehicle slip angle.

1. Brake hard, drive straight (increased load on front wheels)
2. Increase steering command, reduce braking (oversteering)
3. Decrease steering, counter steers, apply throttle to stabilize

Velenis, E., Tsiotras, P., and Lu, J., "Aggressive Maneuvers on Loose Surfaces: Data Analysis and Input Parameterization," *15th IEEE Mediterranean Control Conference*, June 26-29, 2007 Athens, Greece.

# Steering: Trail Braking Maneuver

- Vehicle Dynamics and Control During Abnormal Driving

<http://soliton.ae.gatech.edu/people/dcsl/research-abnormal.html>

Prof. Panagiotis Tsiotras, Georgia Tech



<http://soliton.ae.gatech.edu/people/dcsl/movies/TrailBraking.avi>

# Steering: Pendulum Turn Maneuver (Sim)

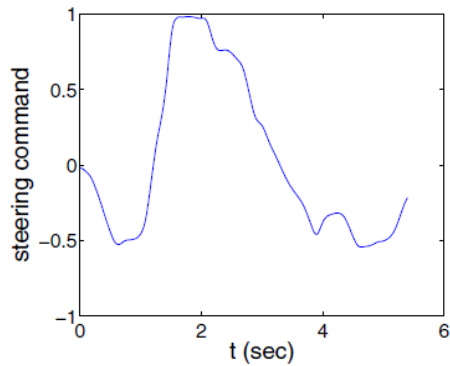

(a)

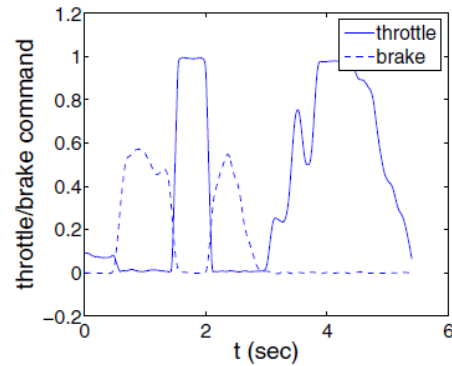

(b)

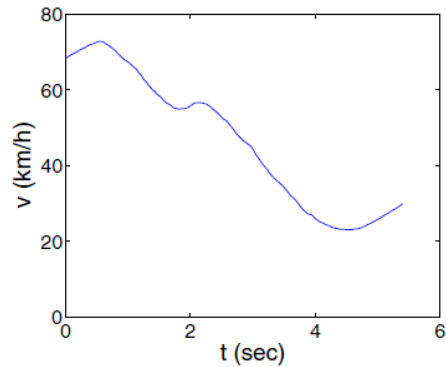

(c)

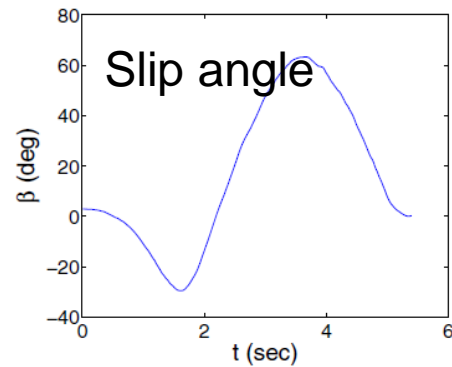

(d)

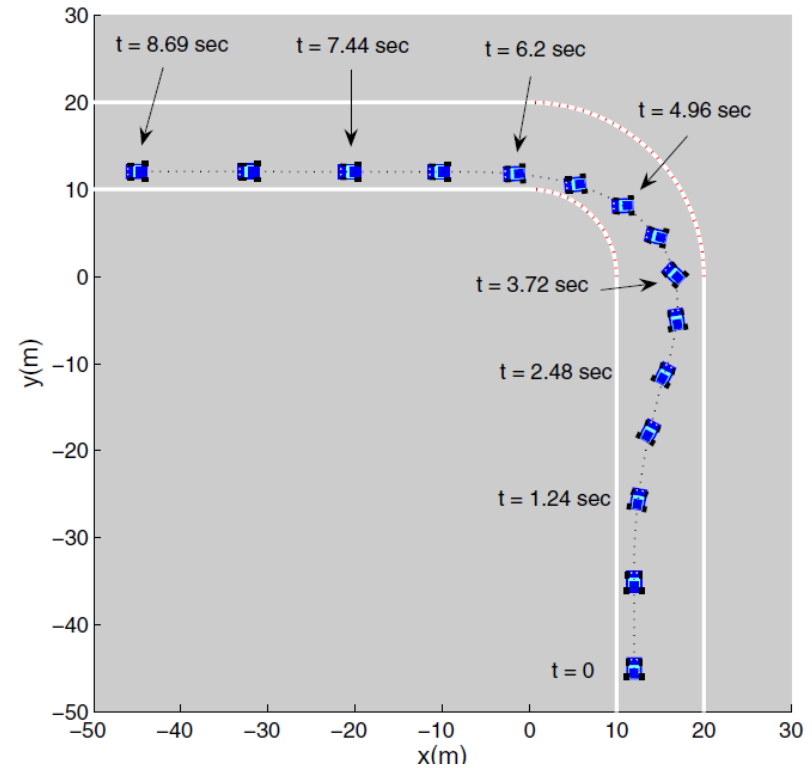

1. Turn opposite while applying brakes (increased load on front wheels, oversteering)
2. Throttle blip to damp rotation
3. steer in direction of turn and apply brakes to rotate fast
4. Decrease steering command, counter-steers, applies throttle to stabilize

Velenis, E., Tsiotras, P., and Lu, J., "Aggressive Maneuvers on Loose Surfaces: Data Analysis and Input Parameterization," *15th IEEE Mediterranean Control Conference*, June 26-29, 2007 Athens, Greece.





<http://soliton.ae.gatech.edu/people/dcs1/movies/PendulumTurn.avi>

# Vehicle Stability through Differential Braking

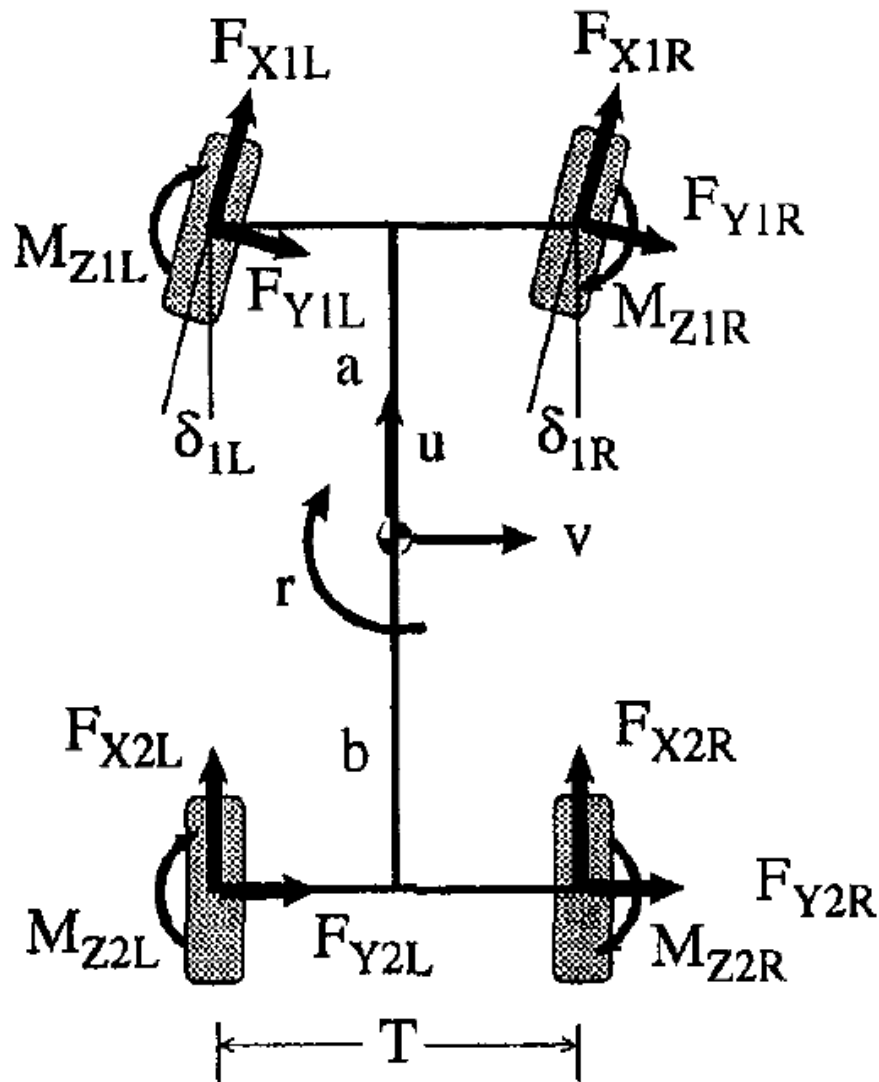

**Fig. 1 Seven DoF vehicle model**

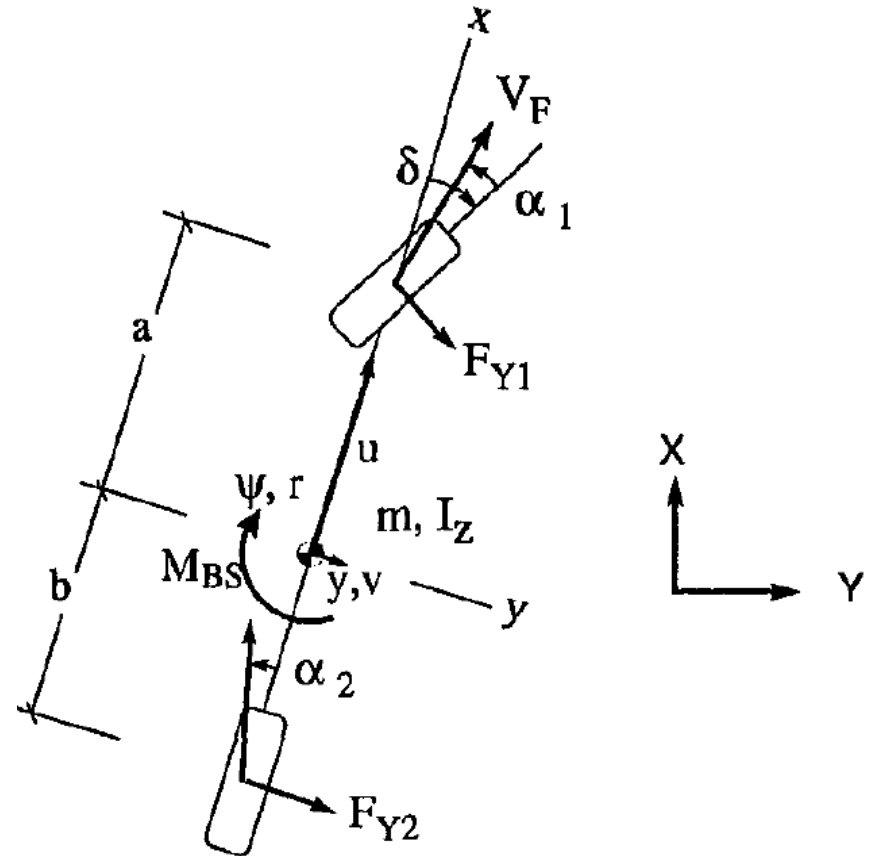

**Fig. 2 Two DoF model**

- T. Pilutti, G. Ulsoy, and D. Hrovat, "Vehicle steering intervention through differential braking," Proc. American Control Conf. Seattle, Wash. June 1995.

# Tire Slip Angle

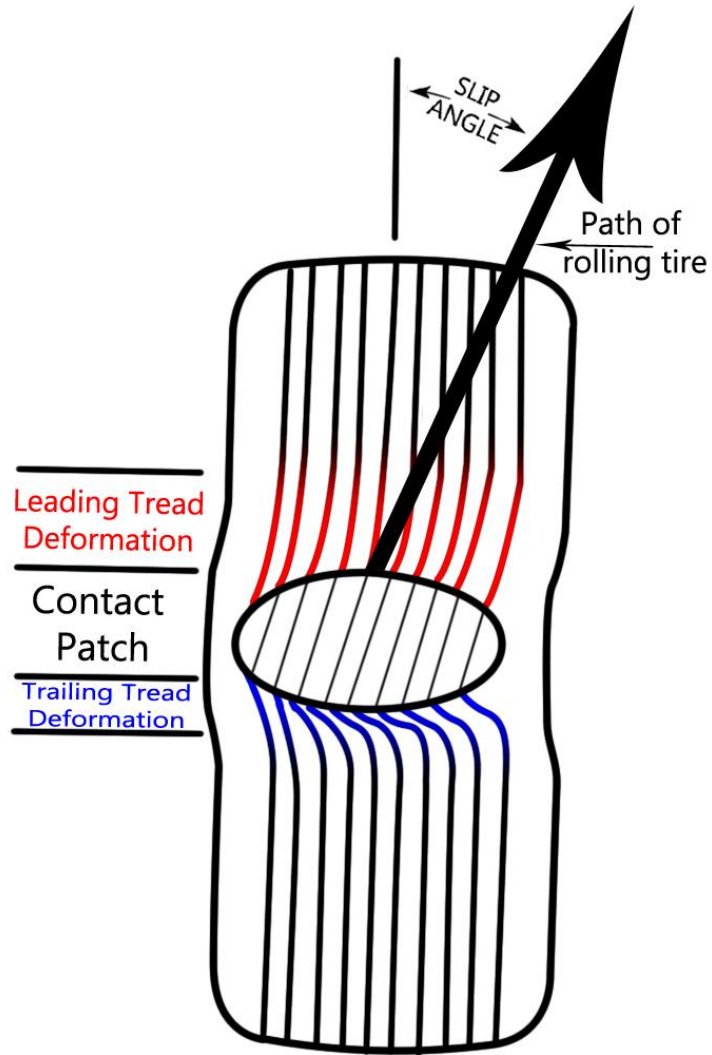

More derivation on board