

Melinda Ler
 14281920
 melindal@eecs.berkeley.edu
 Homework 3

Reference: C:\EE247\units.mcd

Problem 1

1) Find the RLC values

$$\omega_{3dB} := 2 \cdot \pi \cdot 100\text{kHz} \quad R^* := 1\Omega \quad L_r := \frac{R^*}{\omega_{3dB}} \quad C_r := \frac{1}{R^* \cdot \omega_{3dB}}$$

$$C_1 := 0.6395 \cdot C_r \quad C_1 = 1.018 \mu\text{F}$$

$$C_3 := C_1 \quad C_3 = 1.018 \mu\text{F}$$

$$C_2 := 0.0002 \cdot C_r \quad C_2 = 0.318 \text{ nF}$$

$$L_2 := 0.9786 \cdot L_r \quad L_2 = 1.557 \mu\text{H}$$

2) Obtain the signal flow graph for the filter

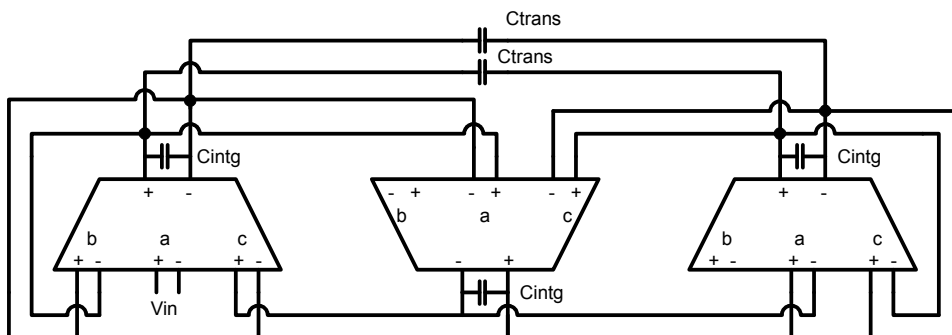
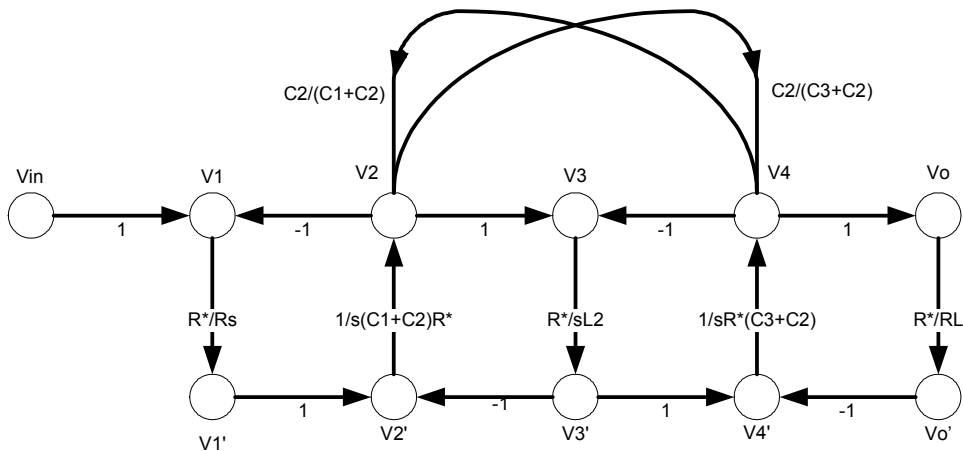

3)

Let $C_{\text{intg}} := 10\text{pF}$

Transmission zero capacitor

$$C_{\text{trans}} := \frac{2 \cdot C_{\text{intg}}}{\left(\frac{C_1 + C_2}{C_2}\right) - 1}$$

$$C_{\text{trans}} = 6.255 \text{ fF}$$

Transconductance of first integrator diff pair

$$\omega_1 := \frac{1}{R^* \cdot (C_1 + C_{\text{trans}})}$$

$$\omega_1 = 982.515 \text{ kHz}$$

$$g_{m1} := \frac{\omega_1 \cdot (2 \cdot C_{\text{intg}} + C_{\text{trans}})}{2}$$

$$g_{m1} = 9.828 \mu \cdot \text{S}$$

Transconductance of second integrator diff pair

$$\omega_2 := \frac{R^*}{L_2}$$

$$\omega_2 = 642.059 \text{ kHz}$$

$$g_{m2} := \frac{\omega_2 \cdot 2 \cdot C_{\text{intg}}}{2}$$

$$g_{m2} = 6.421 \mu \cdot \text{S}$$

Transconductance of third integrator diff pair

$$\omega_3 := \frac{1}{R^* \cdot (C_3 + C_{\text{trans}})}$$

$$\omega_3 = 982.515 \text{ kHz}$$

$$g_{m3} := \frac{\omega_3 \cdot (2 \cdot C_{\text{intg}} + C_{\text{trans}})}{2}$$

$$g_{m3} = 9.828 \mu \cdot \text{S}$$

4) SPICE description

*HW3

```
.lib 'cmos35.txt' nominal
.option POST LIST NOMOD
```

```
.param gm1= 9.828e-6
.param gm2 = 6.421e-6
.param ctran = 6.255f
.param Av = 1e30
.param pole = 100G
*Actual RLC
*-----
Vinrlc vinrlc 0 ac 1
Rsrlc vinrlc vc1rlc 1
C1rlc vc1rlc 0 1.018u
L2rlc vc1rlc vc3rlc 1.557u
C2rlc vc1rlc vc3rlc 0.318n
C3rlc vc3rlc 0 1.018u
Rlrlc vc3rlc 0 1
```

```

*Integrator
*-----
.subckt gmcell vout+ vout- vin1+ vin1- vin2+ vin2- vin3+ vin3- Gm=1 Gain=1e30 NDP=10000MEG
** Transconductor cell **
Gcell1 vout- vout+ VCCS vin1o+ vin1o- Gm
Gcell2 vout- vout+ VCCS vin2o+ vin2o- Gm
Gcell3 vout- vout+ VCCS vin3o+ vin3o- Gm
Cintg vout+ vout- 10p
RL1 vout+ 0 1e12
RL2 vout- 0 1e12
Ro vout+ vout- 'Gain/Gm'
Rpp1 vin1+ vin1o+ 1k
Rpn1 vin1- vin1o- 1k
Cp1 vin1o+ vin1o- '1/(4*3.14*1k*NDP)'
Rpp2 vin2+ vin2o+ 1k
Rpn2 vin2- vin2o- 1k
Cp2 vin2o+ vin2o- '1/(4*3.14*1k*NDP)'
Rpp3 vin3+ vin3o+ 1k
Rpn3 vin3- vin3o- 1k
Cp3 vin3o+ vin3o- '1/(4*3.14*1k*NDP)'
.ends gmcell
* Balun
* -----
.subckt balun vd vc vp vn
e1 vp vc transformer vd gnd 2
e2 vc vn transformer vd gnd 2
.ends balun
* Filter circuit
*-----
Vin vin 0 ac 1
xbalunin vin 0 vinp vinm balun
Xintg1 out1p out1n vinp vinm out1n out1p out2n out2p gmcell Gm = 'gm1' Gain = 'Av' NDP = 'pole'
Xintg2 out2p out2n out1p out1n out3n out3p 0 0 gmcell Gm = 'gm2' Gain = 'Av' NDP = 'pole'
Xintg3 out3p out3n out2p out2n out3n out3p 0 0 gmcell Gm = 'gm1' Gain = 'Av' NDP = 'pole'
Ctrans1 out1p out3p 'ctran'
Ctrans2 out1n out3n 'ctran'
xbalunout3 vout 0 out3p out3n balun
Rout vout 0 1T
.ac dec 100 1 1G
.probe voutdb = par('20*log10(Vm(vout))')
.probe vc3db = par('20*log10(Vm(vc3rlc))')
.alter
.param Av = 1e30
.param pole = 85MEG
.alter
.param Av = 1e30
.param pole = 80MEG
.alter
.param Av = 1e30
.param pole = 78MEG
.alter
.param Av=1e30
.param pole = 70MEG
.end

```

Magnitude response and detailed passband

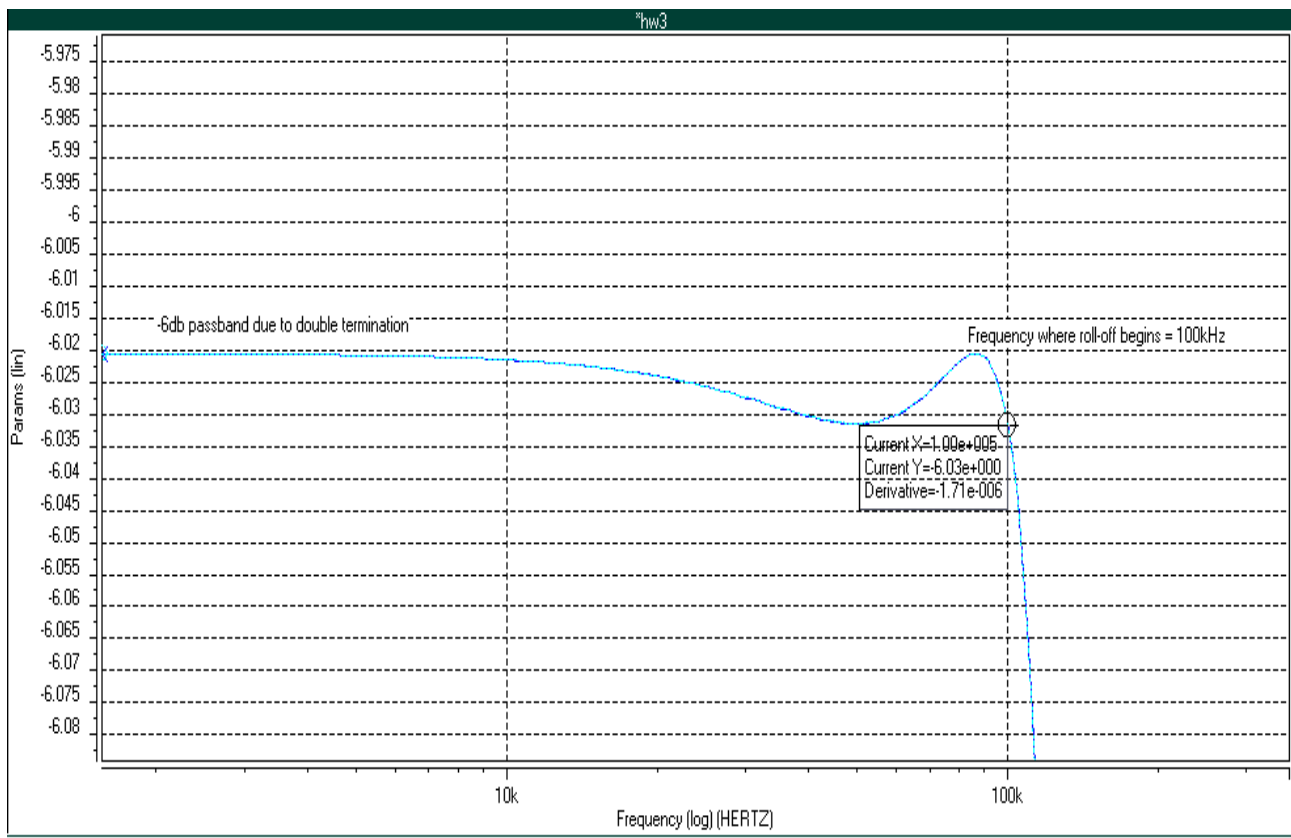
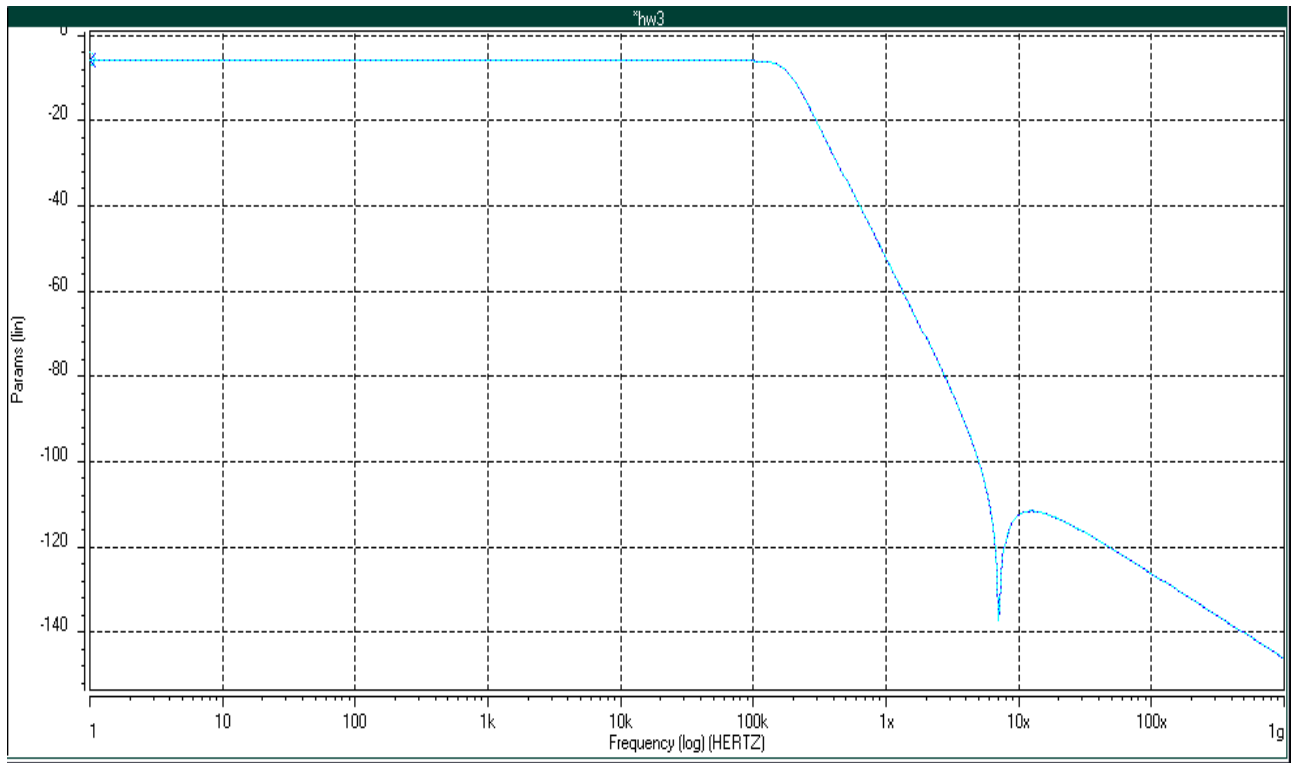

5) Effect of integrator finite gain

Gain = 160 gives us a 0.1dB deviation in the pass band

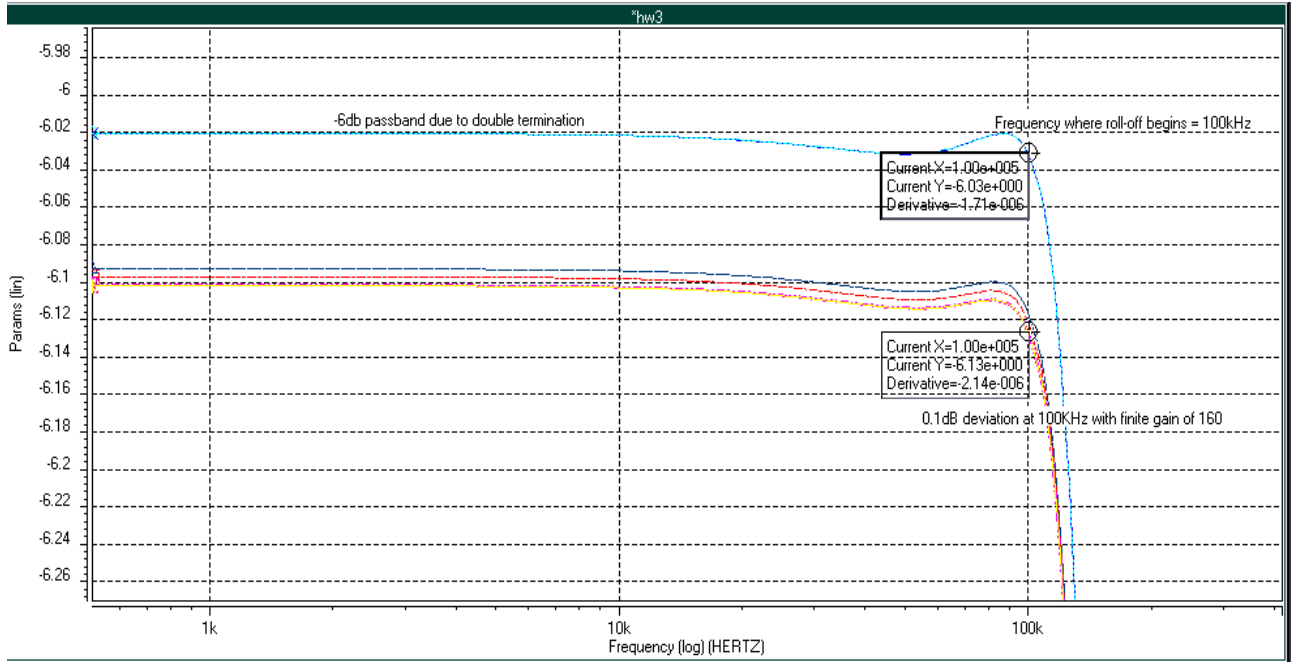

6) Effect of nondominant pole

Pole = 78MHz causes a deviation in the passband of 0.1dB

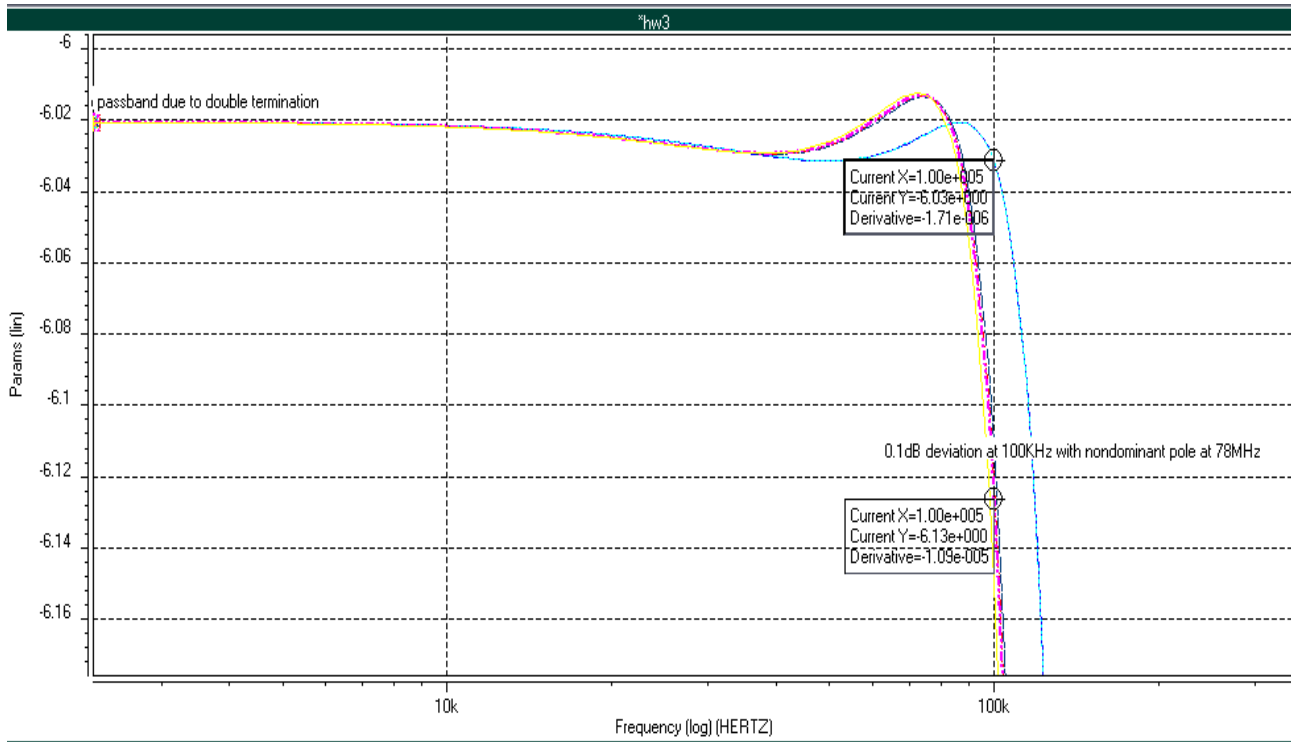

7) Both non-idealities included

The finite gain of the filter causes a phase lead while the nondominant pole causes a phase lag. The effect of the two simultaneously causes a droop in the pass band while reducing the 3dB pole frequency

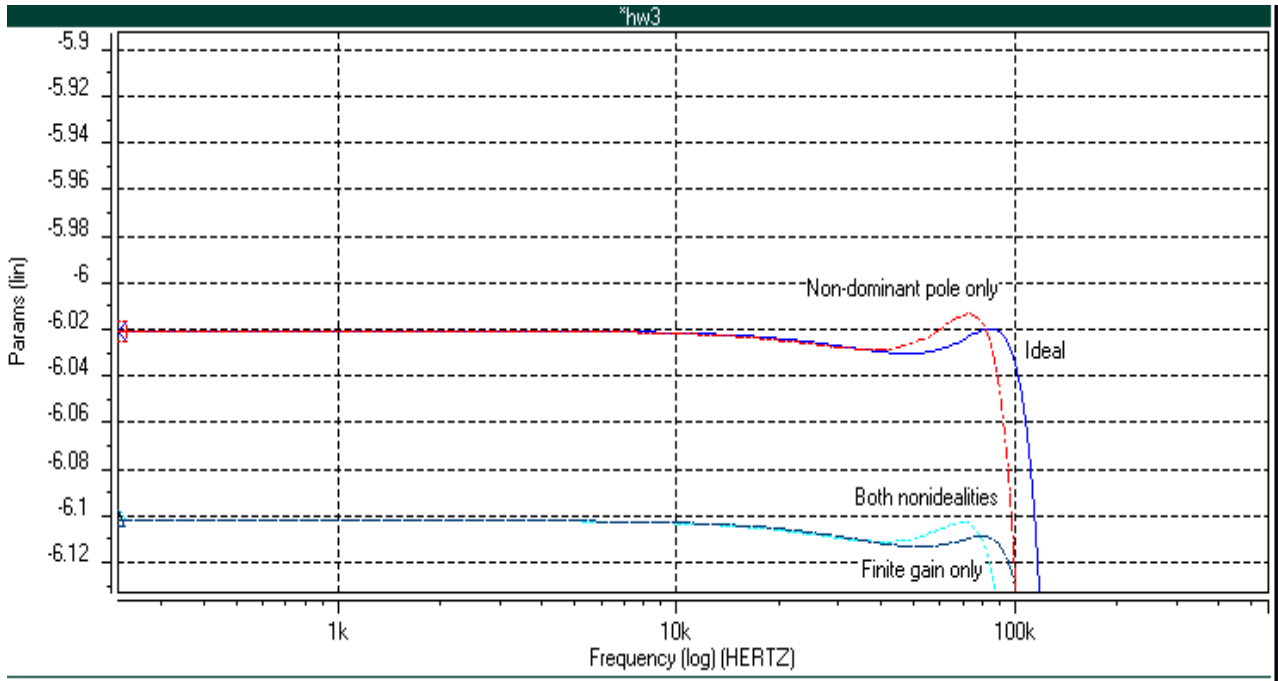

8) Switched-capacitor version of the same filter

$$f_{3dB} := 100\text{kHz}$$

$$f_s := 32 \cdot f_{3dB}$$

$$C_I := 10\text{pF}$$

$$f_s = 3.2\text{MHz}$$

$$\frac{1}{R^*(C_1 + C_2)} = f_s \cdot \frac{C_{s1}}{C_I}$$

$$C_{s1} := \frac{C_I}{f_s \cdot R^* \cdot (C_1 + C_2)}$$

$$C_{s1} = 3.069\text{pF}$$

$$\frac{R^*}{L_2} = f_s \cdot \frac{C_{s2}}{C_I}$$

$$C_{s2} := \frac{C_I \cdot R^*}{f_s \cdot L_2}$$

$$C_{s2} = 2.006\text{pF}$$

$$\frac{1}{R^*(C_3 + C_2)} = f_s \cdot \frac{C_{s3}}{C_I}$$

$$C_{s3} := \frac{C_I}{f_s \cdot R^* \cdot (C_3 + C_2)}$$

$$C_{s3} = 3.069\text{pF}$$

$$C_{trans} = 6.255\text{fF}$$

We make the BMF of the transmission zero branches negative to avoid using negative capacitances. To do so we multiply node V4 and V4' by -1 and transform the corresponding branches going into and coming out from these nodes.

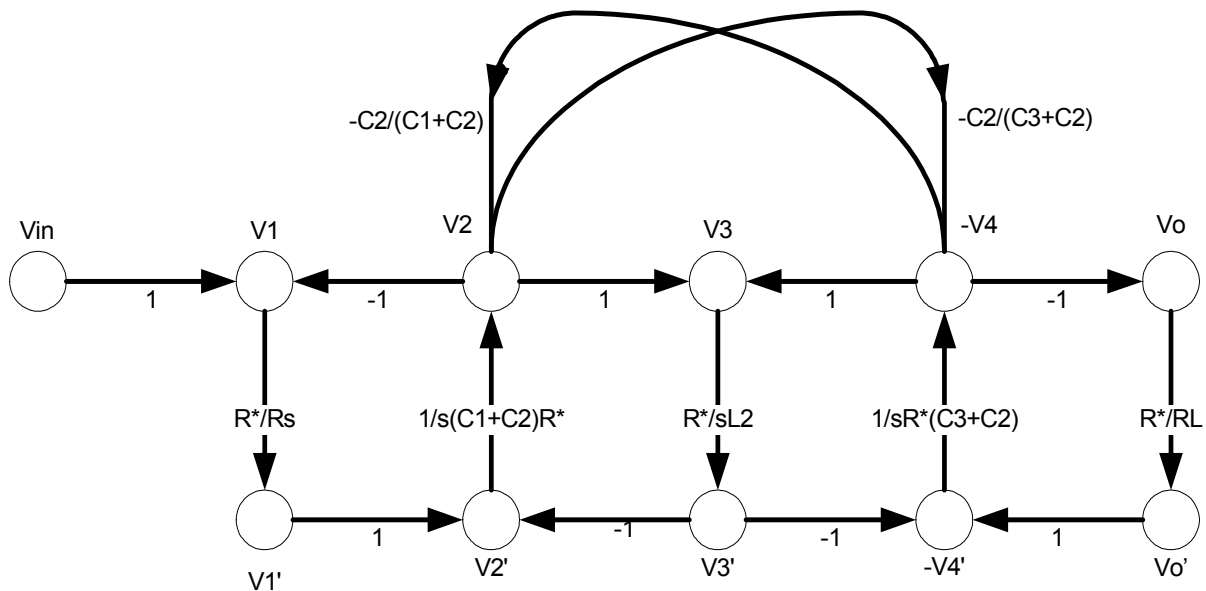

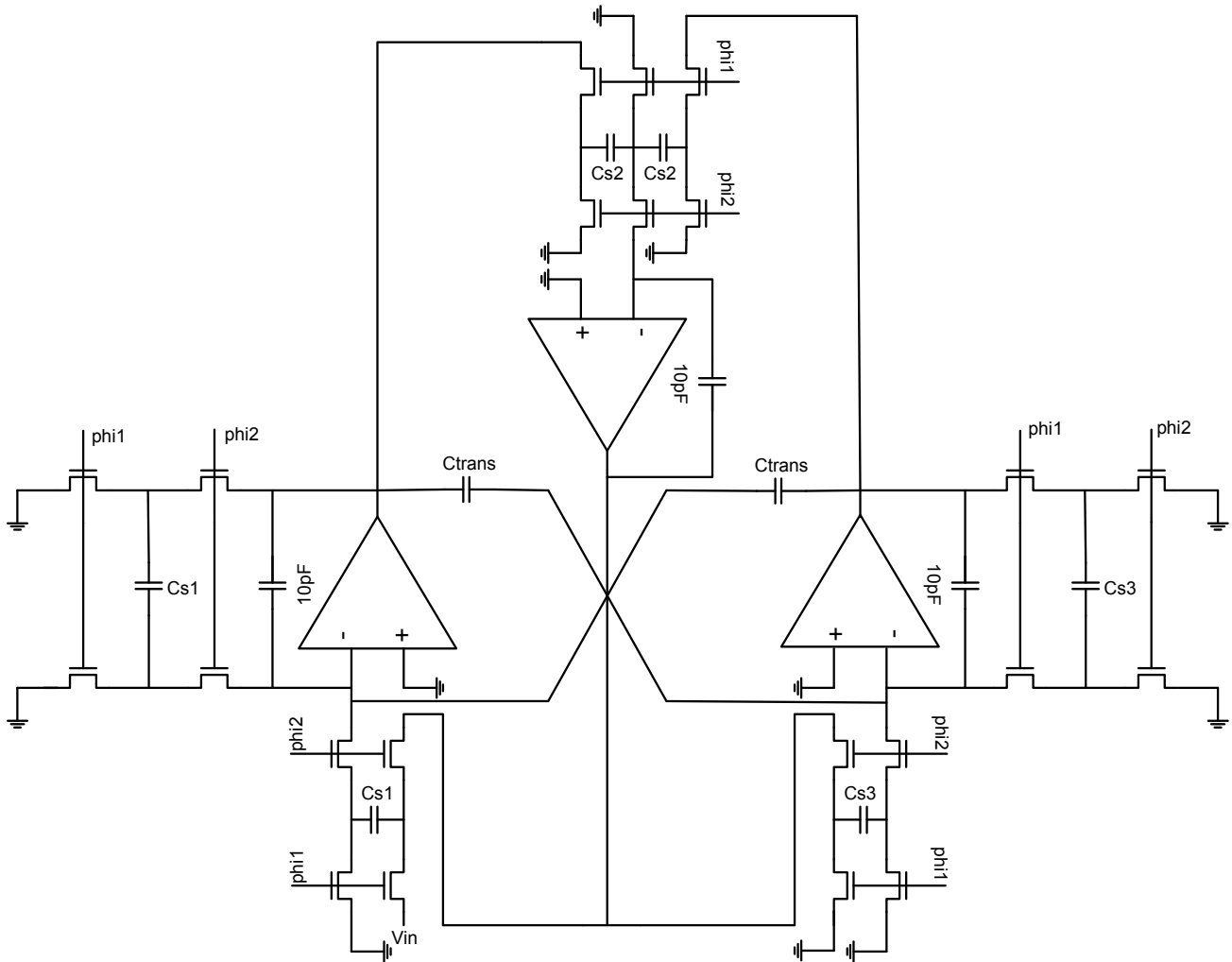

Problem 2

Minimum sampling frequency that guarantee 50dB attenuation of aliasing components in the discrete time signal $y(kT)$ is $30\text{kHz} \times 10 + 15\text{kHz} = 315\text{kHz}$

