

EE 40 Final Project

Part I: General instruction

1. The final project will count for 7.5% of your grade.
2. This project is composed of a basic part and a creation part. A circuit diagram will be provided for the basic part, while no circuit diagram will be given for the creation part.
3. Every effort must be made to team up as a team of 1 or 2, only under very, very, special circumstances and approval by head GSI is required for forming a team of 3. Please try to find your lab partners before hand. One of your team members will keep the board and the components during the project period. Try to protect your progress, and keep it in a good condition.
4. Every group will get a project kit with a piece of breadboard and all the components. Please check with the component list in lab guide part V to see if the kit is complete. Keep it in a good condition during the whole project. We don't have many extra parts to supply if you lose any of them.
5. The grading will be mainly based on the lab report and the circuit functionality. Typed lab report is preferred. Hand written is also fine, but has to be neat and clear. Please see part IV for more information on the lab report.
6. Lab report is due by December 10th. We will have a final competition. You may choose to enter the competition to display your work. The competition will be held on Dec. 10, 2007. The professor and all lab GSIs will attend this reception/competition and select the projects which exemplify work above and beyond the guide instructions. Each group entering the competition must do a 5-10 minutes show and tell.

First place (1 team): TBA

Second place (1 team): TBA

Third place (1 team): TBA

Part II: Basic Circuit—Light Sensor

1. Function analysis

Figure 1. Basic circuit diagram

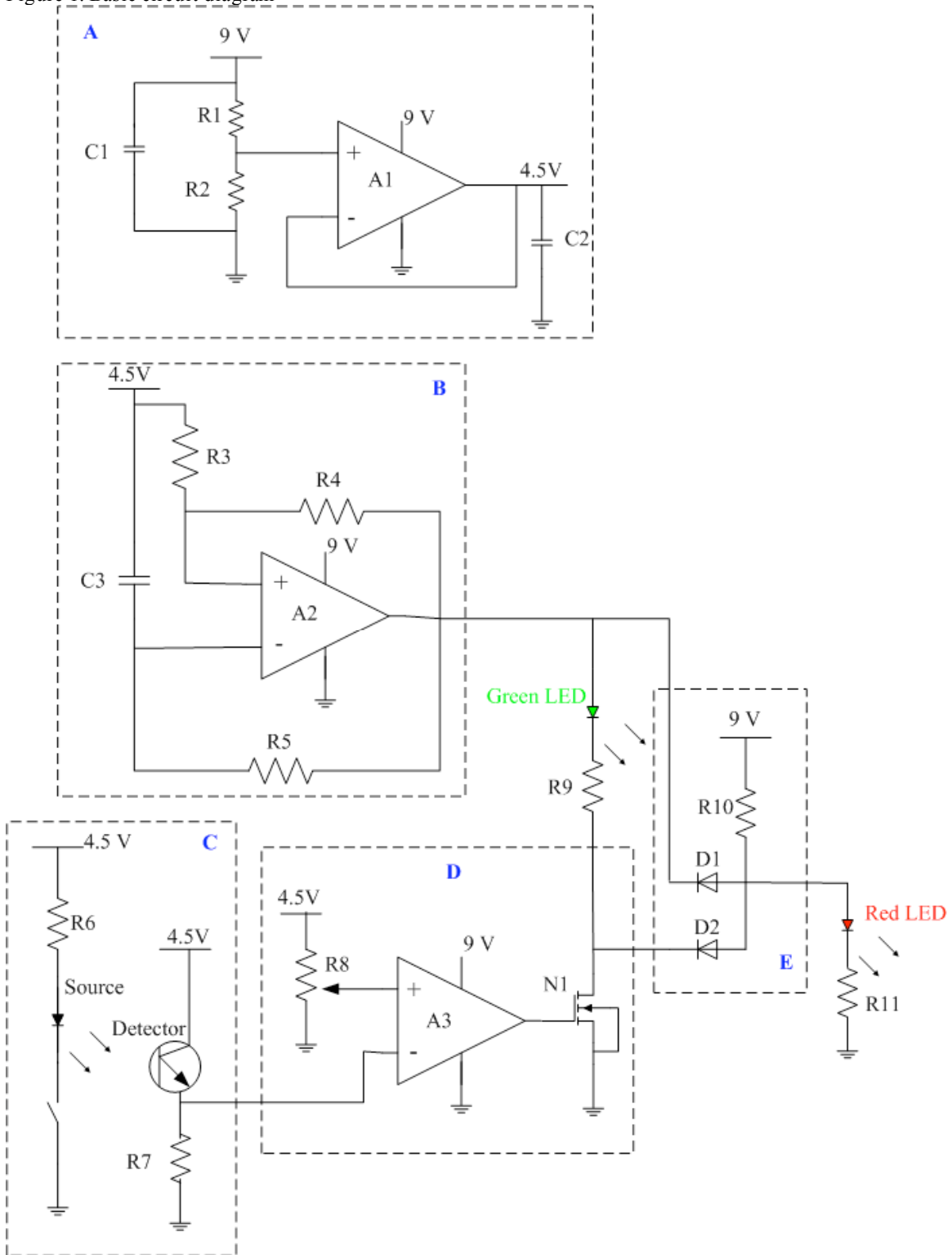

This is a light sensing circuit. When there is no light shinning on the circuit (mainly the detection part), the green LED will be flashing. When light is shinning on the circuit (mainly the detection part), the red LED will start flashing instead of the green one.

The whole circuit can be torn down into 5 basic building blocks labeled A-E in the diagram. We will analyze them one by one in order to understand the functions.

A. 4.5 V DC power supply.

The circuit is going to be powered by a 9 V battery, but lower DC power is also needed in the circuit. Part A is using an op-amp to build up a simple voltage follower which gives 4.5 V output. Since 4.5 V is half of 9 V, resistors R1 and R2 are equal. C1 and C2 are filtering capacitors, which are usually connected in parallel with the DC output in order to filter out any high frequency AC signal coming from the noise.

B. Square wave oscillator.

Let's analyze it in a time sequence and use 4.5 V as the voltage reference. The circuit diagram can be redrawn as shown in Figure 2 (b).

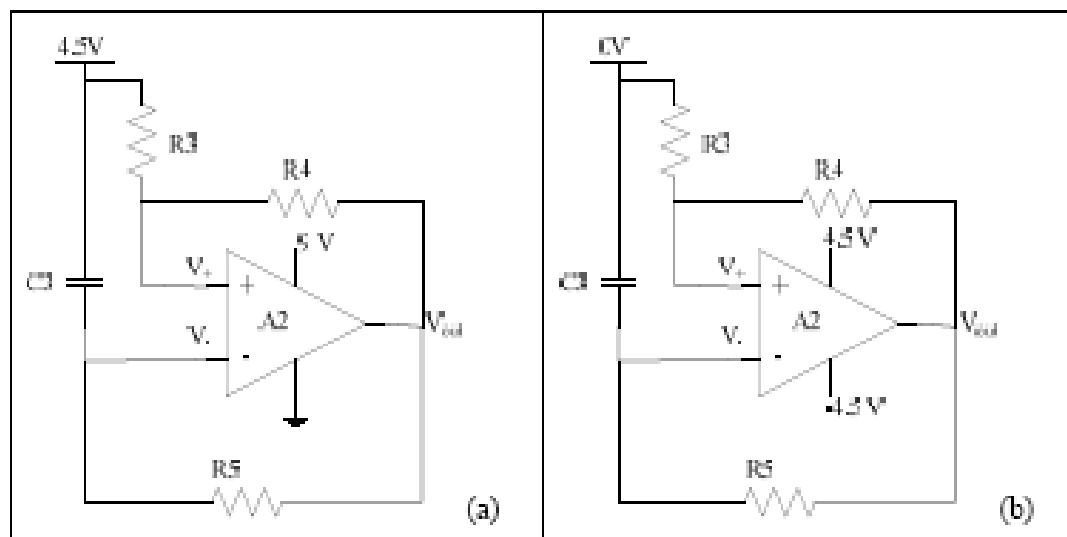

Figure 2. Square wave oscillator (a) with reference at 0 V. (b) with reference at 4.5 V.

Initially $V_{out} = 0$ and there is no charge on the capacitor. However to the reference 4.5 V, $V_{out} = -4.5$ V and $V_- = -4.5$ V. Since this circuit has a positive feedback loop, any slight difference between V_+ and V_- may make V_{out} high or low clamped to the power supply value. In this initial condition, $V_+ = -4.5 \frac{R_3}{R_3 + R_4} > V_- = -4.5$ V, so the output goes high and get clamped to 4.5 V immediately after the circuit is on. Now

the circuit is in state 1: $V_{out} = 4.5 \text{ V}$, $V_+ = 4.5 \frac{R_3}{R_3 + R_4}$ and capacitor C3 is being

charged from V_{out} . So V_- is rising up. When V_- is as high as or just slightly higher than V_+ , the circuit toggles because of the positive feedback. Output will be clamped at -4.5 V since $V_- > V_+$. Now the circuit is in state 2: $V_{out} = -4.5 \text{ V}$ and

$V_+ = -4.5 \frac{R_3}{R_3 + R_4}$. The capacitor is being discharged from V_{out} . And V_- is falling

down. When V_- is as low as V_+ or just slightly lower than V_+ , the circuit toggles again because of the positive feedback. Then the output is clamped at 4.5 V again,

$V_+ = 4.5 \frac{R_3}{R_3 + R_4}$ and the capacitor is being charged from V_{out} again.

Therefore, we see that the circuit is toggling between the two states, and the output voltage is either 4.5 V or -4.5 V , which forms a periodic square wave. To understand the oscillation function better, we draw wave forms at V_+ , V_- and V_{out} on the same scale as shown in Figure 3(b). It's clear that the threshold voltages of output high and

low are $4.5 \times \frac{R_3}{R_3 + R_4} \text{ V}$ and $-4.5 \times \frac{R_3}{R_3 + R_4} \text{ V}$. Go back to the original circuit with

reference at 0 V . We just need to add a DC offset 4.5 V to all the result and waveforms

as shown in Figure 3 (a). The threshold voltages changes to $4.5 \frac{2R_3 + R_4}{R_3 + R_4}$ and

$$4.5 \frac{R_4}{R_3 + R_4}.$$

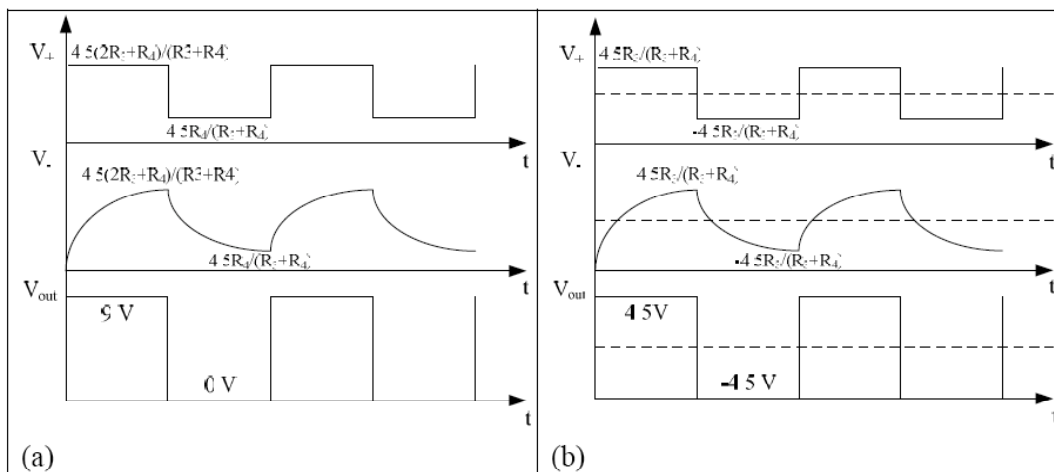

Figure 3. Waveforms of V_+ , V_- and V_{out} (a) with reference of 0 V . (b) with reference of 4.5 V

C. Light generation and detection.

Light generation can be realized by a visible LED or any white light source (room light, flash light etc.). Light source intensity is determined by the detector sensitivity. Phototransistor can be used as a detector. Light exposure will increase the current flowing through the phototransistor. Photoresistor is another choice, whose resistance will change when exposed to the light.

Infrared (IR) LED and detector are also available for light generation and detection.

D. Comparator and buffer.

Open loop op-amp can be used as a comparator. Positive input connects to a fixed DC voltage used as a reference. Negative input connects to the detector end. When detector detects light, current increases. Therefore the voltage across R7, which is connected to the negative input of the op-amp, increases. When it's lower than the reference voltage, the output will be high—9 V. When it's higher than the reference, the output is low—0 V. Thus the light on/off is converted to L/H of the op-amp output. An NMOS will be connected to the output of the comparator as a buffer since the output will be driving the LED and the logic circuit following. When comparator output (gate voltage of the NMOS) is low, the NMOS is off, thus the drain is high or floating. When comparator output is high, the NMOS is on, thus the drain is grounded. This way, we realize the light on/off to output H/L conversion.

E. AND gate.

Only when both inputs are high, the output is high, which will light up the red LED.

Based on the functions of all the building blocks, the function of the whole circuit is as follows. When light is off, the comparator buffer output is low. So the AND output is low, thus red LED is off. However, the oscillator output will make the green LED flashing. When the light is on, the comparator buffer output is high (9 V), so the AND gate output is high when the oscillator output is in the high period, thus the square wave signal is transmitted to the red LED, which will be flashing then. In addition, because of LED is a diode, which can only work in one direction, the green LED is off when comparator buffer output is high.

2. Hands-on

To build and debug each block separately and then combine them together to realize the whole function will make the process faster and easier. Try to make your circuit clear, compact and neat. It will be nice-looking and easy to debug.

We give general considerations of how to select values of the components and provide recommended values and specifications for some parts.

A. Op-amp is LMC 6482, the same as we used in Lab 6. Power supply will be from a 9 V battery. So V+ (pin 8) is 9 V and V- (pin 4) is 0 V or ground of the circuit. Since the output is 4.5 V, half of the power, we need two equal resistors for R1 and R2. To make the power consumption low, we use 10kΩ for R1 and R2. Filter capacitors C1 and C2 can be 10μF. Smaller values can be used if high frequency noise exists. BE CAREFUL THE POLARITY OF THE CAPACITORS, when connecting them to DC voltage.

B. Human eyes can differentiate frequency smaller than 30 Hz. So we need to make the oscillator frequency in the range 1 ~ 30 Hz. In order to express the frequency in terms of R3, R4 and R5 and C3, let's do some calculations based on the analysis in the above section. Since the two threshold values are symmetric as shown in Figure 3, we know that the duty cycle of the square wave is 50% (half period 9 V and half period 0 V). The period of the square wave is decided by the capacitor charging time constant $R_5 \times C_3$. Let's use the rising half period of V- in Figure 3(a). Since this is a first order RC circuit, the rising part can be express as:

$$V_- = 9 \left(1 - e^{-\frac{t}{R_5 C_3}} \right). \text{ At time } t_1, V_- = 9 \left(1 - e^{-\frac{t_1}{R_5 C_3}} \right) = 4.5 \frac{R_4}{R_3 + R_4}; \text{ at time } t_2,$$

$$V_- = 9 \left(1 - e^{-\frac{t_2}{R_5 C_3}} \right) = 4.5 \frac{2R_3 + R_4}{R_3 + R_4}. \text{ The time period } t_2 - t_1 = \frac{T}{2}, \text{ where } T \text{ is the}$$

period of the square wave. So

$$\frac{T}{2} = t_2 - t_1 = R_5 C_3 \ln \frac{2(R_3 + R_4)}{R_4} - R_5 C_3 \ln \frac{2(R_3 + R_4)}{2R_3 + R_4} = R_5 C_3 \ln \frac{2R_3 + R_4}{R_4}.$$

So the period is $T = 2R_5 C_3 \ln \frac{2R_3 + R_4}{R_4}$, and the frequency is

$$f = \frac{1}{T} = \frac{1}{2R_5 C_3 \ln \frac{2R_3 + R_4}{R_4}}. \text{ The falling half period of V- will give the same}$$

solution of the period or frequency since the signal is symmetric. So to control the frequency in the range of 1~30 Hz, we use R3=R5=10 kΩ, R4=510 Ω and C3=10 μF. Plug all these numbers in the frequency equation, we have the frequency of 1.35 Hz, which is detectable by human eyes.

C. For the light generation, if room light or flash light is being used; there is no need for light generation circuit. If infrared (IR) LED is being used; the maximum current is around 30 mA, and threshold voltage is about 1.7 V. So we use R6 = 200 Ω or similar to keep the current below 30 mA.

For the detection part, we use different R7 for different detectors. If phototransistor is being used, which can detector intense white light (flash light

has to be the source), R7 can be 10 kΩ to keep the current smaller than the maximum 25 mA and also keep the power consumption low. Please see Figure 4 for the pin configuration and connection of the phototransistor.

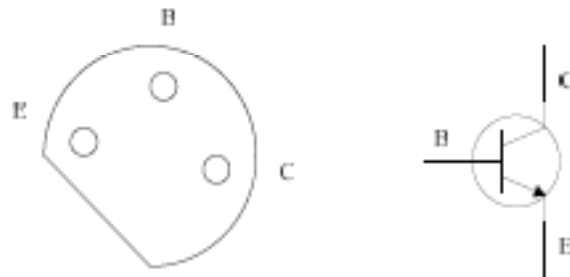

Figure 4. Phototransistor FPT100 pin configuration.

If photoresistor is being used, which can detect just the room light with lower sensitivity, R7 = 1 kΩ would be a good choice. With room light on, the resistance can be about 50 Ω, depending on the light intensity. With room light off or simply blocking the surface of it, the resistance can be as high as 1 MΩ. Then R7 and the

photoresistor form a simple voltage divider. So $V_+ = \frac{R_7}{R_7 + R_{\text{detector}}} \times 4.5 \text{ V}$. Table 1

gives a summary of components, values as well as output voltage ranges of different source/detector schemes.

Source/Detector	R6 (Ω)	R7 (Ω)	Output /V-(V)
Flash light / photoresistor	-	10 k	0~4
Room light / photoresistor	-	1 k	2~4
IR LED / IR detector	200	10 k	0~4

Table 1. Light source and detector schemes

- D. Pot R8 is a voltage divider too. It needs to be tuned to the value that makes the output voltage roughly in the middle of the on-off range of V- in order to distinguish light-on and light-off states. 5kΩ pot will be used to provide the voltage reference. Turn it until the output voltage is about 2.5-3 V or even higher, depending on which detector is being used. The NMOS is BS170. The gate threshold voltage is about 2.2 V. Please refer to the spec for more information.
- E. D1 and D2 can be 1N4148. To keep the current smaller than 30 mA for all the diodes (D1, D2 and LEDs), we use R9 = 1kΩ, R10 = R11 = 510Ω. Any other similar values will be fine too.

Table 2 summarizes all the components you may need to build the basic circuit.

R1	10 k Ω	C1	10 μ F
R2	10 k Ω	C2	10 μ F
R3	10 k Ω	C3	10 μ F
R4	510 Ω	D1/D2	1N4148
R5	10 k Ω	N1	BS170
R6	-/-/ 200 Ω	Op-amp	LMC 6482
R7	10k Ω /1 k Ω /10 k Ω	Light source	Flash / Room / IR LED
R8	5 k Ω pot	Detector	photoresistor/ IR detector
R9	1 k Ω		
R10	510 Ω	Battery	9 V
R11	510 Ω	LEDs	Green and Red

Table 2. Basic circuit components summary

Part III: Creation Portion

For each question, you have to provide a circuit diagram with components' values, design analysis (including function analysis and value selection), and measured results similar to your analysis required in the basic lab.

Please address all the important issues or difficulties you encounter in your design and experiment. Please indicate if you realize the required function. Even if you didn't realize the function completely, partial credit will be given if you provide good detailed measurements and explanations and can explain what problems you ran into.

- (1). Maintaining the basic function of the circuit, add a buzzer to it to make it buzz with the red LED in phase. When the red LED is on, the buzzer should buzz, when the red LED is off, the buzzer should keep silent. Note – the buzzer will not work powered with just a DC voltage. It is like a speaker and requires some AC signal within the range of human hearing (a good range to try would be around 200Hz to 1kHz, which is close to human speech).
- (2). Make the LED flashing speed adjustable.
- (3) Make the buzzer pitch adjustable.
- (4). Maintaining the basic function of the circuit, add another yellow LED flashing together with the green one, but out of phase (or with π phase shift), which means when green is on, yellow is off and vice versa. However, when the red LED is on, both green and yellow should be off.

Part IV: Lab report

1. Basic circuit (100 pt)

Please report the result of each building block.

A. 4.5 V DC power supply (20 pt)

- _ Draw circuit diagram with component values. (4 pt)
- _ Do analysis on the circuit, such as design principles, important issues.(6 pt)
- _ Provide measured results, such as important voltage levels etc. (6 pt)
- _ Comparison between analysis and measurement. (2 pt)
- _ Building block function description. (2 pt)

B. Square wave generator (25 pt)

- _ Draw circuit diagram with component values. (5 pt)
- _ Do analysis on the circuit, such as design principles, important issues.(8 pt)
- _ Provide measured results, such as wave forms, signal frequency, important voltage levels etc. (8 pt)
- _ Comparison between analysis and measurement. (2 pt)
- _ Building block function description. (2 pt)

C. Light generation and detection (20 pt)

- _ Draw circuit diagram with component values. Indicate the scheme that you use. If you use multiple schemes, please describe them all. (4 pt)
- _ Do analysis on the circuit, such as design principles, important issues.(8 pt)
- _ Provide measured results, such as wave forms, signal frequency, important voltage levels etc. (6 pt)
- _ Building block function description. (2 pt)

D. Comparator and buffer (25 pt)

- _ Draw circuit diagram with component values. (5 pt)
- _ Do analysis on the circuit, such as design principles, important issues.(8 pt)
- _ Provide measured results, such as wave forms, signal frequency, important voltage levels etc. (8 pt)
- _ Building block function description. (4 pt)

E. AND gate (10 pt)

- _ Draw circuit diagram with component values. (3 pt)
- _ Do analysis on the circuit, such as design principles, important issues.(3 pt)
- _ Provide measured results, such as wave forms, signal frequency, important voltage levels etc. You may want to provide measured logic table for this case. (3 pt)
- _ Building block function description. (1 pt)

2. Creation portion (44 pt)

- _ Draw circuit diagram with component values. (5 pt/each part)
- _ Do analysis on the circuit, such as design principles, important issues.(3 pt/ each part)
- _ Provide measured results, such as wave forms, signal frequency, important voltage levels etc. (3 pt/each part)

Part V: Component list

Component	Value	Quantity
Resistor	10 k Ω	8
	1 k Ω	3
	510 Ω	3
	200 Ω	1
Pot	10 k Ω	2
	5 k Ω	1
Capacitor	10 μ F	3
	0.1 μ F	1

Component	Model	Quantity
Op-amp	LMC 6482	2
NMOS	BS170	3
PMOS	ZVP2106A	1
Diode	1N4148	2
LED	Green, Yellow, Red	3
IR LED	512-QED423	1
IR detector	512-QSD723	1
Photoresistor	-	1
Buzzer	-	1
Battery	9 V	1
Breadboard	-	1