

Lecture #11 (with Prof. Ross)

Announcement

- Midterm 1 on Tues. 3/2/04, 9:30-11
- A-M last initials in 10 Evans
- N-Z initials in Sibley auditorium
- Closed book, no electronic devices
- One sheet 8.5x11 inch of your notes
- Covers material through op-amps, i.e. hw #1-4

OUTLINE

- Transient response of 1st-order circuits
- Application: modeling of digital logic gate

Reading

Chapter 4 through Section 4.3

Transient Response of 1st-Order Circuits

- In Lecture 10, we saw that the currents and voltages in RL and RC circuits decay exponentially with time, with a characteristic time constant τ , when an applied current or voltage is suddenly removed.
- In general, when an applied current or voltage suddenly changes, the voltages and currents in an RL or RC circuit will change exponentially with time, from their initial values to their final values, with the characteristic time constant τ :

where $x(t) = x_f + [x(t_0^+) - x_f] e^{-(t-t_0^+)/\tau}$ (nt)

x_f is the final value of the circuit variable
 t_0 is the time at which the change occurs

Procedure for Finding Transient Response

1. Identify the variable of interest

- For RL circuits, it is usually the inductor current $i_L(t)$
- For RC circuits, it is usually the capacitor voltage $v_c(t)$

2. Determine the initial value (at $t = t_0^+$) of the variable

- Recall that $i_L(t)$ and $v_c(t)$ are continuous variables:

$$i_L(t_0^+) = i_L(t_0^-) \quad \text{and} \quad v_c(t_0^+) = v_c(t_0^-)$$

- Assuming that the circuit reached steady state before t_0 , use the fact that **an inductor behaves like a short circuit in steady state** or that **a capacitor behaves like an open circuit in steady state**

Procedure (cont'd)

3. Calculate the final value of the variable (its value as $t \rightarrow \infty$)

- Again, make use of the fact that **an inductor behaves like a short circuit in steady state ($t \rightarrow \infty$)** or that **a capacitor behaves like an open circuit in steady state ($t \rightarrow \infty$)**

4. Calculate the time constant for the circuit

$\tau = L/R$ for an RL circuit, where R is the Thévenin equivalent resistance “seen” by the inductor

$\tau = RC$ for an RC circuit where R is the Thévenin equivalent resistance “seen” by the capacitor

Example: RL Transient Analysis

Find the current $i(t)$ and the voltage $v(t)$:

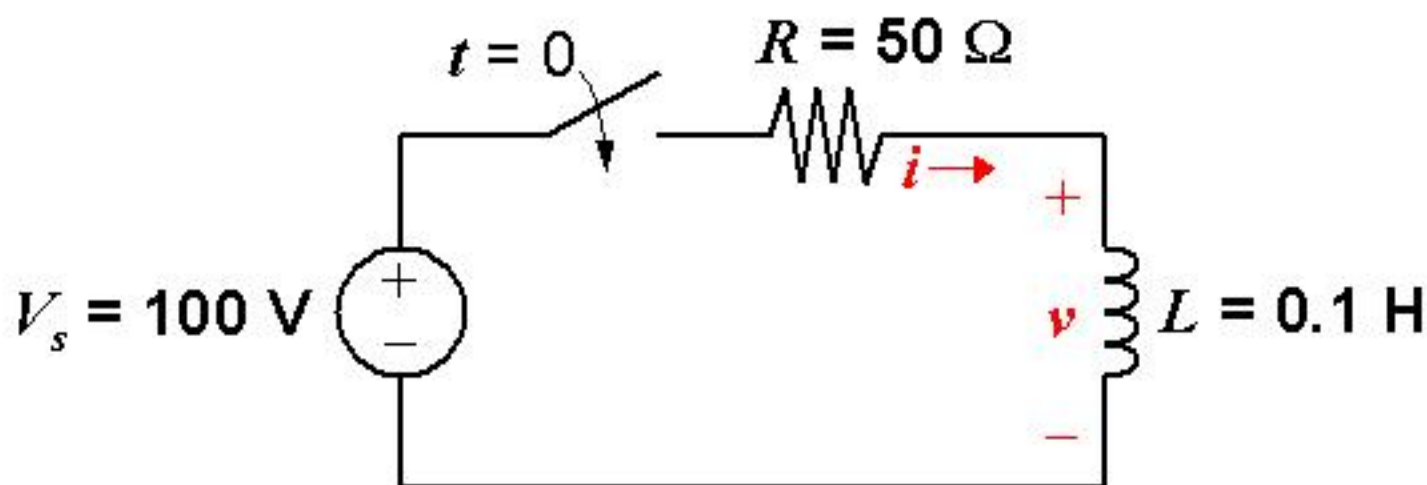

1. First consider the inductor current i
2. Before switch is closed, $i = 0$
--> immediately after switch is closed, $i = 0$
3. A long time after the switch is closed, $i = V_s / R = 2\text{ A}$
4. Time constant $L/R = (0.1\text{ H}) / (50\ \Omega) = 0.002\text{ seconds}$

$$i(t) = 2 + [0 - 2]e^{-(t-0)/0.002} = 2 - 2e^{-500t}\text{ Amperes}$$

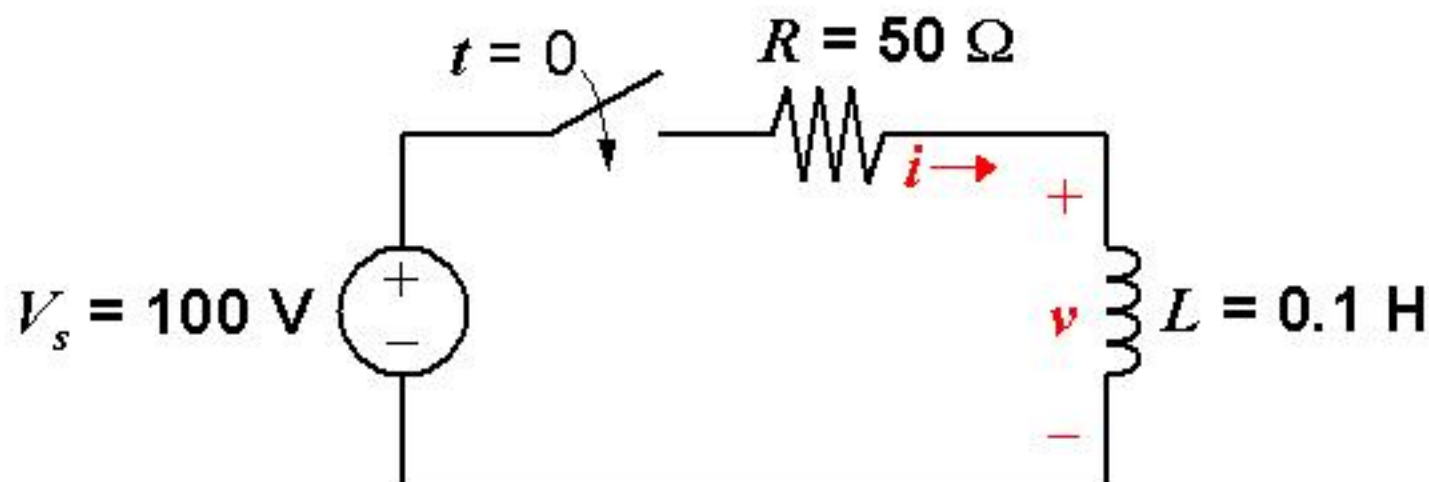

Now solve for $v(t)$, for $t > 0$:

$$\text{From KVL, } v(t) = 100 - iR = 100 - (2 - 2e^{-500t})(50)$$

Example: RC Transient Analysis

Find the current $i(t)$ and the voltage $v(t)$:

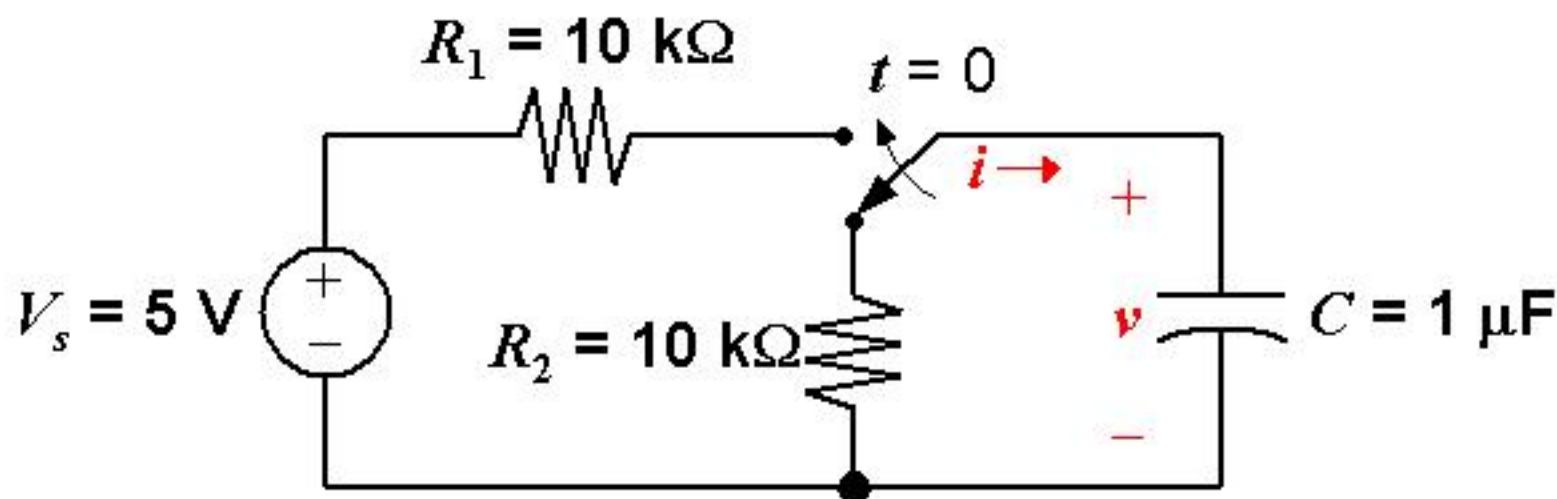

1. First consider the capacitor voltage v
2. Before switch is moved, $v = 0$
--> immediately after switch is moved, $v = 0$
3. A long time after the switch is moved, $v = V_s = 5\text{ V}$
4. Time constant $R_1 C = (10^4\ \Omega)(10^{-6}\ \text{F}) = 0.01\text{ seconds}$

$$v(t) = 5 + [0 - 5] e^{-(t-0)/0.01} = 5 - 5e^{-100t}\text{ Volts}$$

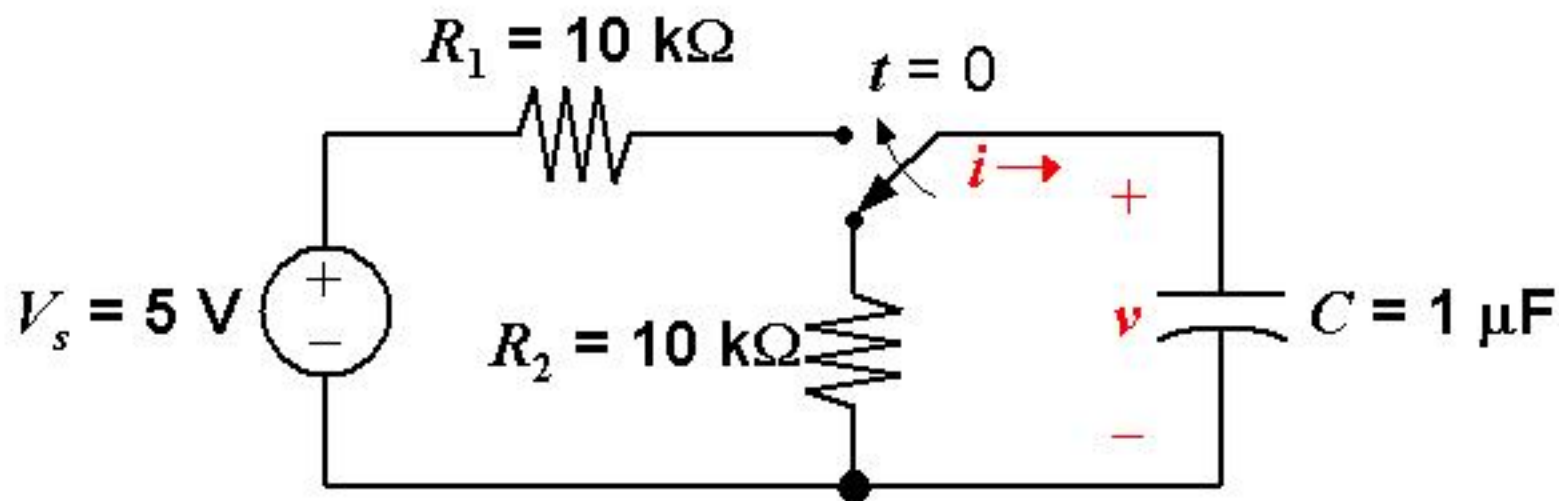

Now solve for $i(t)$, for $t > 0$:

$$\text{From Ohm's Law, } i(t) = \frac{V_s - v(t)}{R_1} = \frac{5 - (5 - 5e^{-100t})}{10^4}$$

Application to Digital Integrated Circuits (ICs)

When we perform a sequence of computations using a digital circuit, we switch the input voltages between **logic 0** (e.g. 0 Volts) and **logic 1** (e.g. 5 Volts).

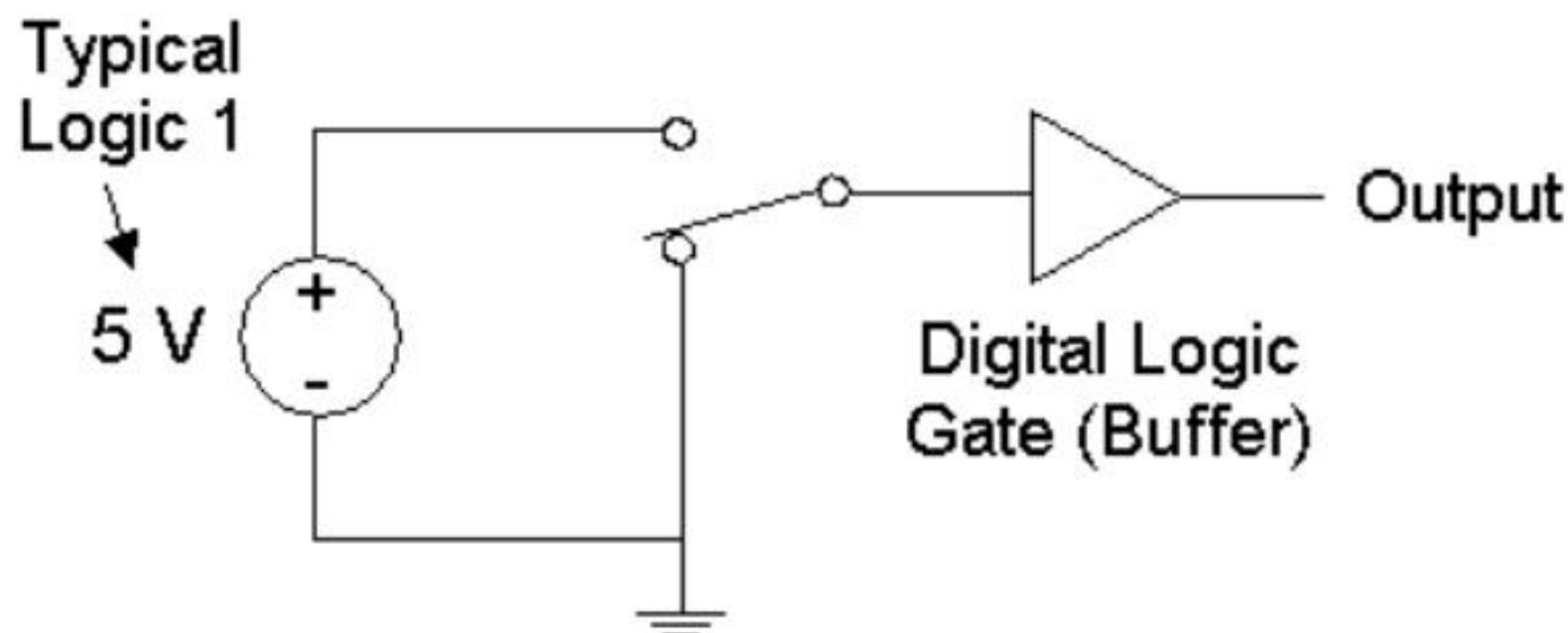

The output of the digital circuit changes between **logic 0** and **logic 1** as computations are performed.

Digital Signals

We compute with pulses.

We send beautiful pulses in:

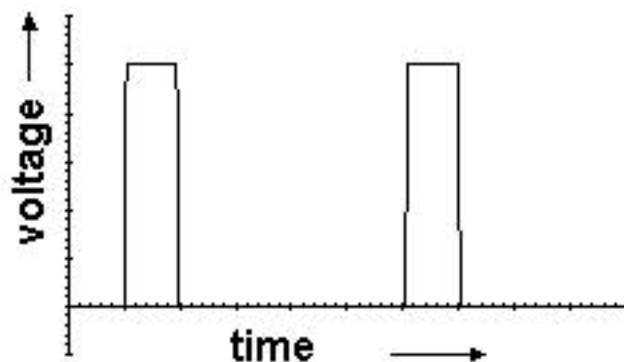

But we receive lousy-looking pulses at the output:

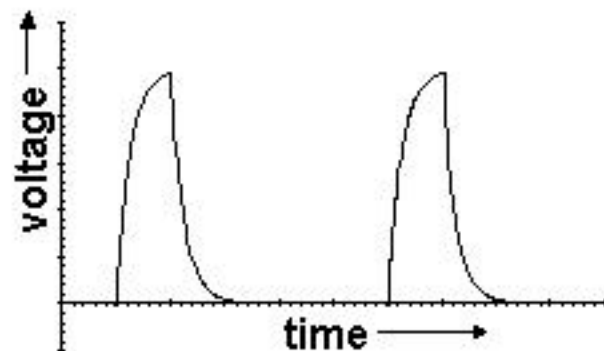

Capacitor charging effects are responsible!

- Every node in a real circuit has capacitance; it's the charging of these capacitances that limits circuit performance (speed)

Circuit Model for a Logic Gate

- Recall (from Lecture 1) that electronic building blocks referred to as “logic gates” are used to implement logical functions (NAND, NOR, NOT) in digital ICs
 - Any logical function can be implemented using these gates.
- A logic gate can be modeled as a simple RC circuit:

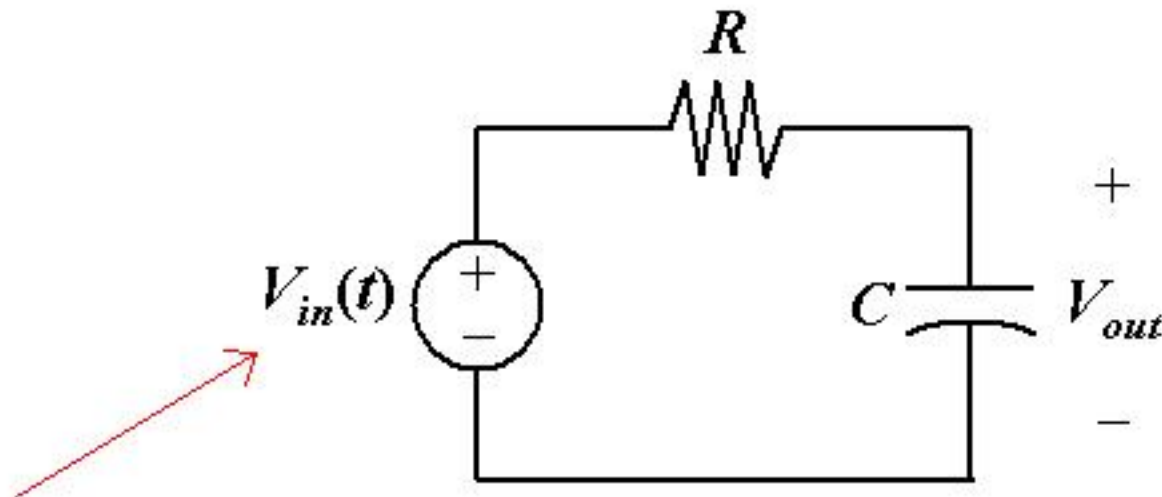

**switches between “low” (logic 0)
and “high” (logic 1) voltage states**

Logic Level Transitions

Transition from “0” to “1”
(capacitor charging)

$$V_{out}(t) = V_{high} \left(1 - e^{-t/RC}\right)$$

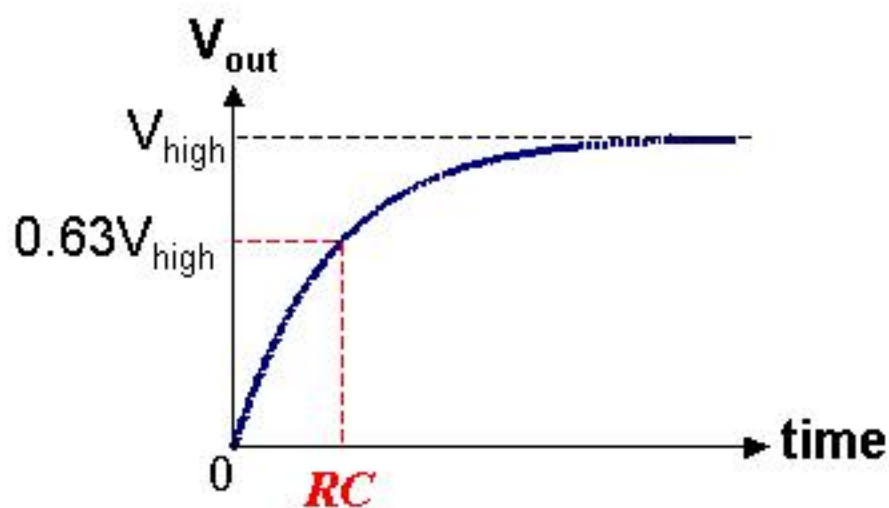

Transition from “1” to “0”
(capacitor discharging)

$$V_{out}(t) = V_{high} e^{-t/RC}$$

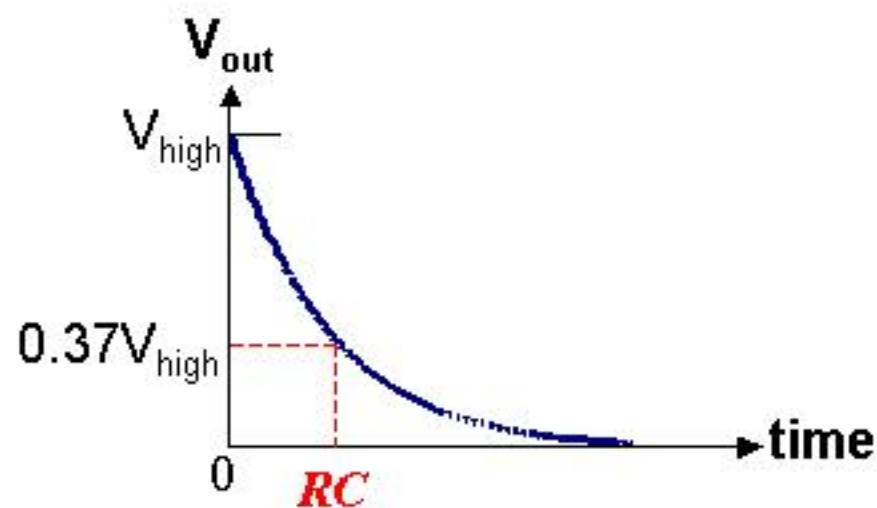

(V_{high} is the logic 1 voltage level)

Sequential Switching

What if we step up the input,

wait for the output to respond,

then bring the input back down?

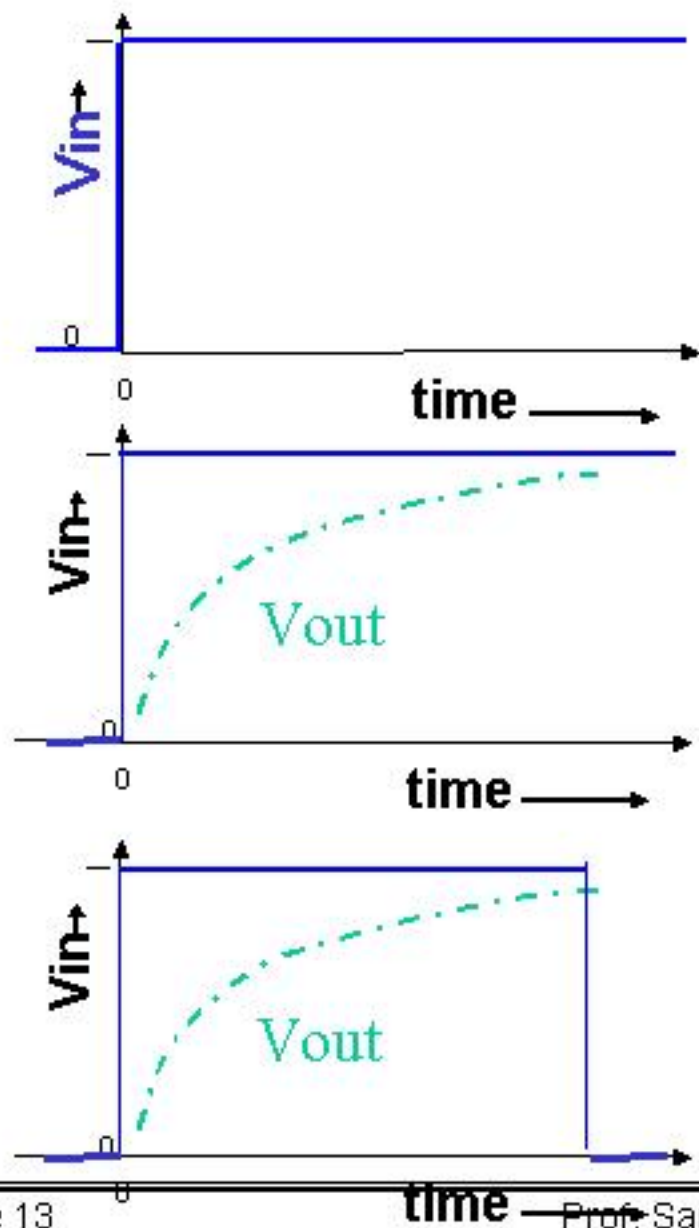

Pulse Distortion

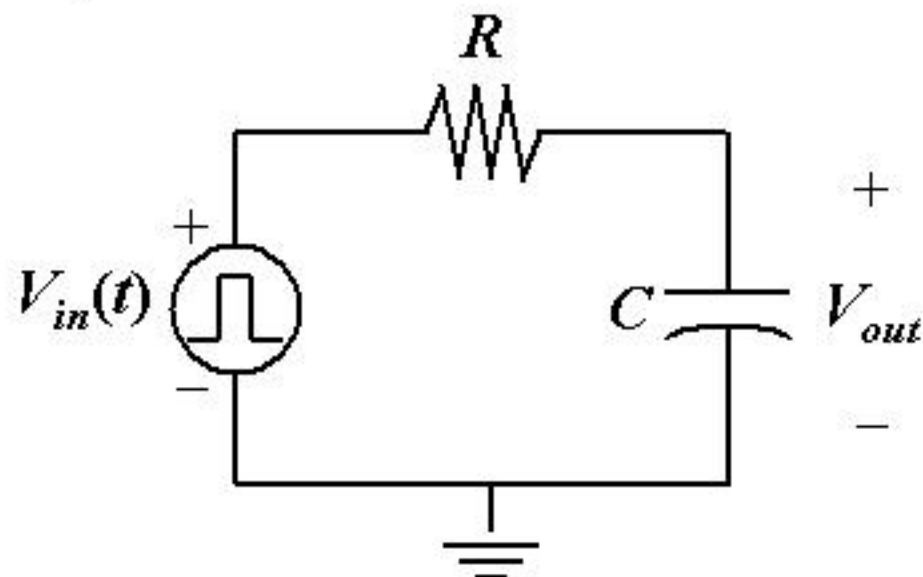

The input voltage pulse width must be long enough; otherwise the output pulse is distorted.

(We need to wait for the output to reach a recognizable logic level, before changing the input again.)

Pulse width = $0.1RC$

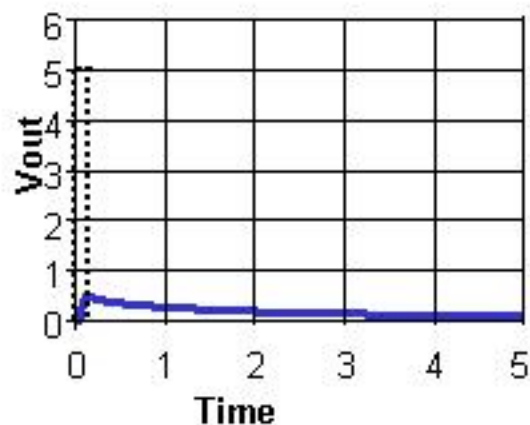

Pulse width = RC

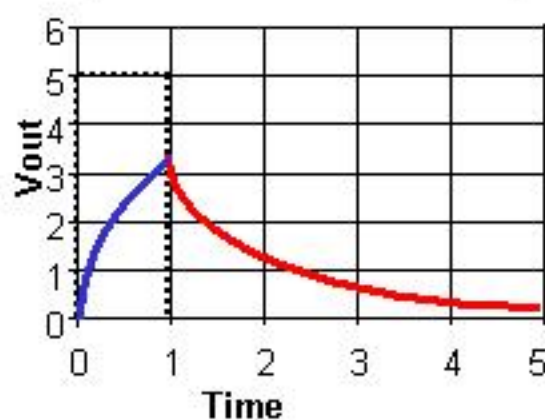

Pulse width = $10RC$

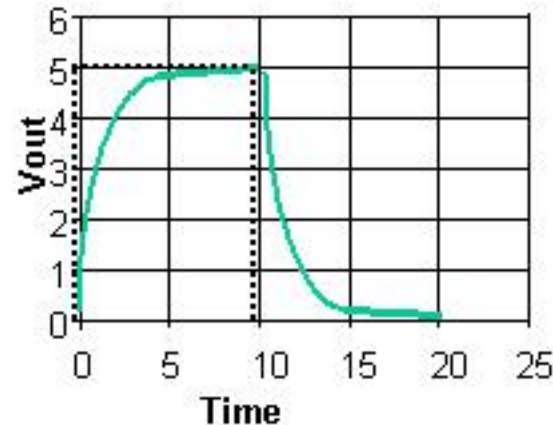

Example

Suppose a voltage pulse of width $5 \mu\text{s}$ and height 4 V is applied to the input of this circuit beginning at $t = 0$:

$$\tau = RC = 2.5 \mu\text{s}$$

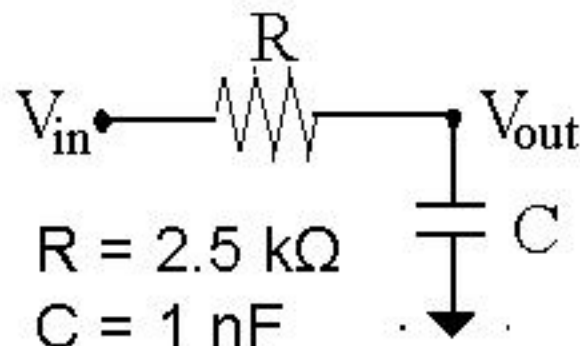

- First, V_{out} will increase exponentially toward 4 V .
- When V_{in} goes back down, V_{out} will decrease exponentially back down to 0 V .

What is the peak value of V_{out} ?

The output increases for $5 \mu\text{s}$, or 2 time constants.

→ It reaches $1 - e^{-2}$ or 86% of the final value.

$$0.86 \times 4 \text{ V} = 3.44 \text{ V} \text{ is the peak value}$$

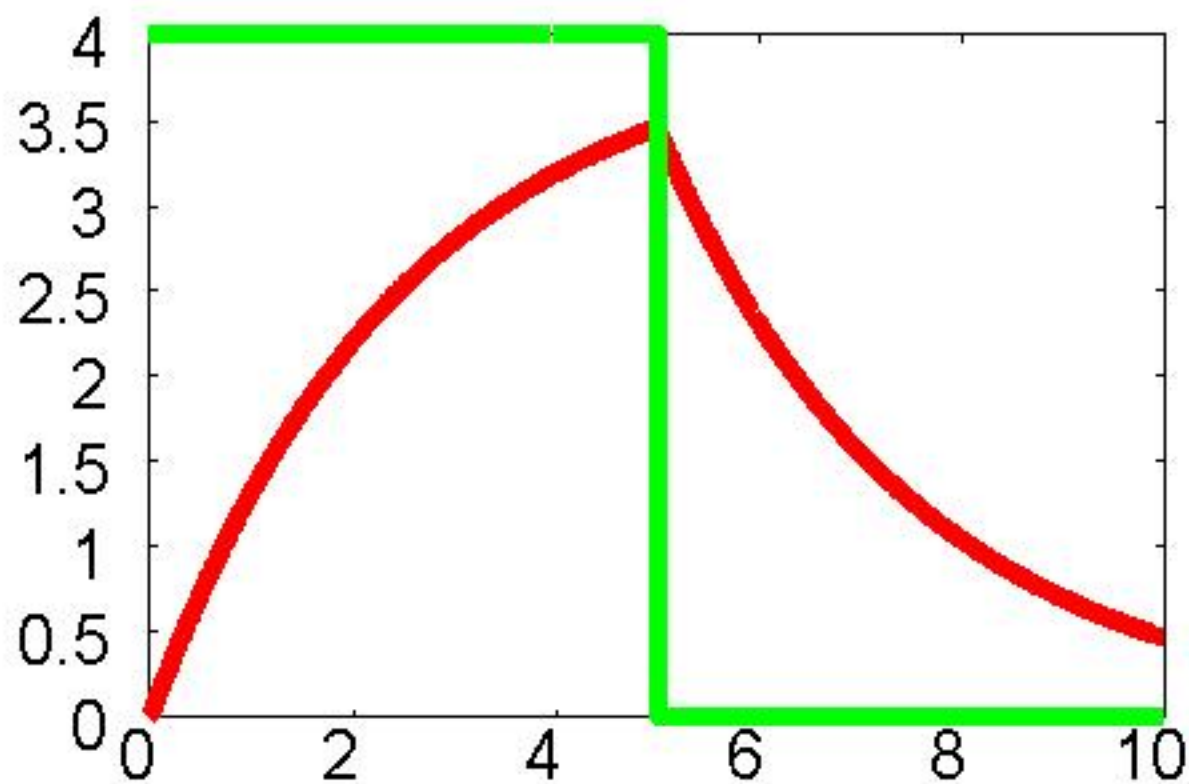

$$V_{out}(t) = \begin{cases} 4 - 4e^{-t/2.5\mu\text{s}} & \text{for } 0 \leq t \leq 5 \mu\text{s} \\ 3.44e^{-(t-5\mu\text{s})/2.5\mu\text{s}} & \text{for } t > 5 \mu\text{s} \end{cases}$$