

EECS 40/42/100, Spring 2007
Prof. Chang-Hasnain

Homework #9

Due at 6 pm in 240 Cory on Wednesday, 04/04/07
Total Points: 100

- Put (1) your name and (2) **discussion section number** on your homework.
- You need to put down all the derivation steps to obtain full credits of the problems. Numerical answers alone will at best receive low percentage partial credits.
- No late submission will be accepted expect those with prior approval from Prof. Chang-Hasnain.

1. Hambley, P14.33
2. Hambley, P14.39
3. Hambley, P14.52
4. Hambley, P14.63
5. Hambley, P14.67
6. Hambley, P10.7
7. Hambley, P10.16
8. Hambley, P10.20
9. Hambley, P10.21
10. Hambley, P10.33 and P10.34a.

11. (EE 40 only – this is problem 10 from homework 8) Consider the following circuit with positive feedback, with all resistors 1k, and the capacitor 1 μ F.

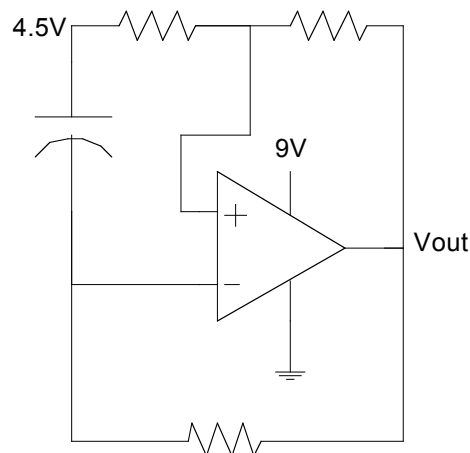

- a) Suppose the capacitor is initially charged to -4.5V . What is $V_{\text{out}}(0)$?
- b) Assuming this V_{out} does not change for some period of time (call the first time at which it changes t_1), Derive expressions for $V_+(t)$ and $V_-(t)$ for $0 < t < t_1$.
- c) What is the value of t_1 ? (Hint: How does V_{out} depend on V_+ and V_- ?)
- d) Now that V_{out} has changed, Derive new expressions for $V_+(t)$ and $V_-(t)$ for $t_1 < t < t_2$, where t_2 is the next time V_{out} changes.
- e) What is the value of t_2 ?
- f) Plot $V_+(t)$, $V_-(t)$, and $V_{\text{out}}(t)$ for t ranging from 0 to 5ms.
- g) What function does this circuit perform?