

## EECS 40 Pre-Lab: RC Circuits

Name: \_\_\_\_\_  
TA: \_\_\_\_\_ Section: \_\_\_\_\_

Please read the lab manual first then show your work here.

$$V = Q/C = [ \int i(t)dt ] / C$$

Differentiating this equation, we obtain  $i(t) = C(dV/dt)$

1. If a constant current of 1.0 mA were to flow into a 200  $\mu\text{F}$  (microfarad) capacitor, what would be the voltage across the capacitor after 3 seconds?

2. Describe what would happen theoretically if you were to connect an ideal current source to the following circuits. Use time plots of the voltage across the capacitor and the resistor to illustrate.

a)

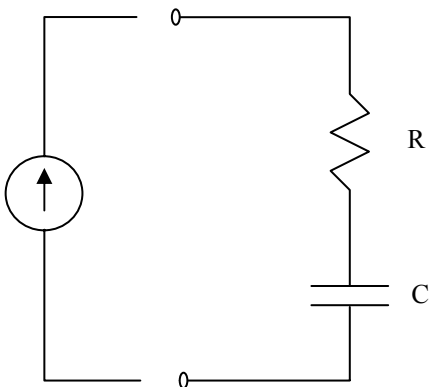

b)

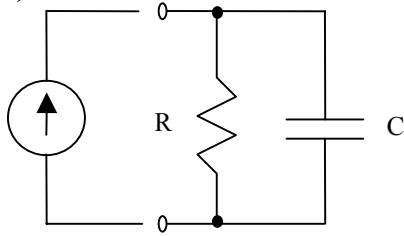

3. An RC (resistor + capacitor) circuit will have an exponential voltage response of the form  $v(t) = A + B e^{-t/RC}$  where A and B are constants that express the final voltage and the difference between the initial voltage and the final voltage, respectively.

a. Given  $R = 10 \text{ k}\Omega$  and  $C = 0.1 \text{ }\mu\text{F}$ , a starting voltage of 5 Volts and an ending voltage of 0 Volts, what will the voltage be at  $t = 1 \text{ ms}$ ?

b. At what time will the voltage be 0.5 Volts?

4. Suppose you were given two black boxes, which have either a series or parallel combination of R and C. In the case of the series RC, you would not be able to touch a probe between the R and the C in the black box, so how would you go about determining R and C using the signal generator, the oscilloscope and an external resistance? (Hint: read the lab)

5. Consider the following RLC (2<sup>nd</sup> order) circuit.

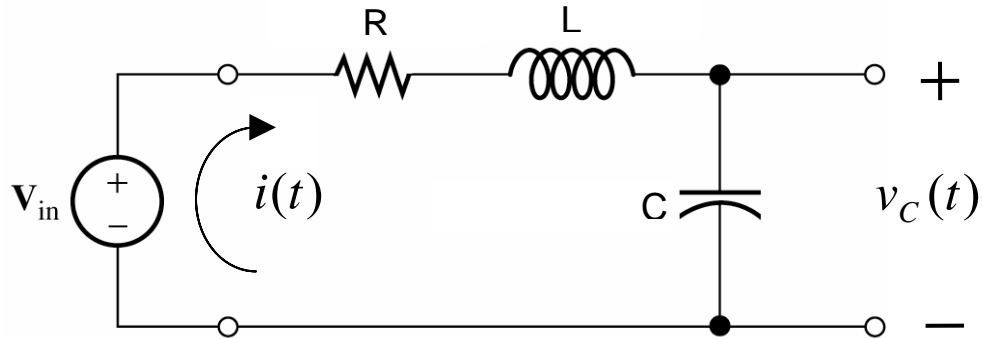

**a.** Write the KVL equation for the above circuit. This will be an equation in terms of the components' values,  $v_C(t)$ ,  $i(t)$ , and their derivatives. Use what you know about capacitors to rewrite your expression as a differential equation in terms of solely  $v_C(t)$  and its derivatives.

**b.** Divide your equation through by the necessary values so that the second-order ( $d^2/dt^2$ ) term has coefficient 1 (This should now be in the general form from (Eq. 10 in the Lab Guide). What is the resonant frequency  $\omega_0$ ? What is the damping factor  $\alpha$ ?

**c.** Let  $L = 10$  mH,  $C = 1$  nF. What is the resonant frequency  $\omega_0$ ?

**d.** What value of  $R$  will result in critical damping? Calculate  $\alpha$ . How does this compare to the resonant frequency  $\omega_0$ ?

**e.** Choose a value for  $R$  that will produce the underdamped solution, and calculate  $\alpha$ . What is the resonant frequency  $\omega_0$ ? What is the natural frequency  $\omega_n$ ? How long is the period,  $T$ , of a wave oscillating at the natural frequency?

**f.** Repeat part d. for overdamping.