

EECS 40 Pre-Lab: RC Circuits

Name: _____
TA: _____ Section: _____

Please read the lab manual first then show your work here.

$$V = Q/C = [\int i(t)dt] / C$$

Differentiating this equation, we obtain $i(t) = C(dV/dt)$

1. If a constant current of 1.0 mA were to flow into a 200 μF (microfarad) capacitor, what would be the voltage across the capacitor after 3 seconds?

2. Describe what would happen theoretically if you were to connect an ideal current source to the following circuits. Use time plots of the voltage across the capacitor and the resistor to illustrate.

a)

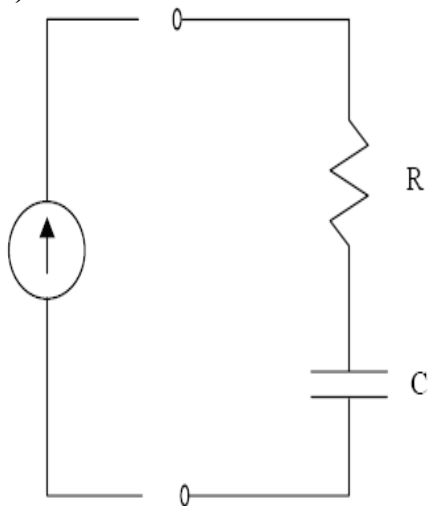

b)

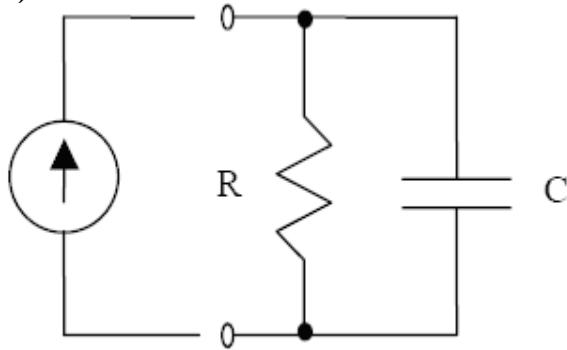

3. An RC (resistor + capacitor) circuit will have an exponential voltage response of the form $v(t) = A + B e^{-t/RC}$ where A and B are constants that express the final voltage and the difference between the initial voltage and the final voltage, respectively.

a. Given $R = 10 \text{ k}\Omega$ and $C = 0.1 \text{ }\mu\text{F}$, a starting voltage of 5 Volts and an ending voltage of 0 Volts, what will the voltage be at $t = 1 \text{ ms}$?

b. At what time will the voltage be 0.5 Volts?

4. Suppose you were given two black boxes, which have either a series or parallel combination of R and C. In the case of the series RC, you would not be able to touch a probe between the R and the C in the black box, so how would you go about determining R and C using the signal generator, the oscilloscope and an external resistance? (Hint: read the lab)

5. Consider the following RC (1st order) circuit.

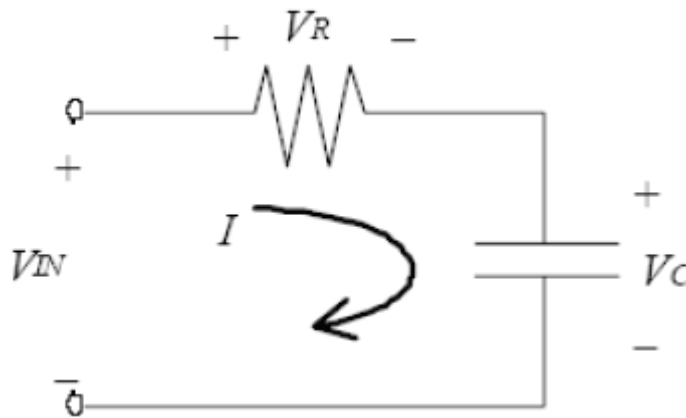

a) Assume the voltage across capacitor (capacitance C) is $V \sin(\omega t + \theta)$. Find the current through the capacitor. (Hint: read the lab)

b) What will be the voltage across resistor? (resistance R)

c) For a resistor, we can always use Ohm's Law to find its resistance if the voltage across and the current through the resistor is given. Let's treat the capacitor as a resistor and apply Ohm's Law to find its "resistance" and define it as the impedance of the capacitor. What is the impedance of the capacitor in this case? [Hint: $\frac{A \cos(\omega t + \theta_1)}{B \cos(\omega t + \theta_2)} = \frac{A}{B} \cos(\omega t + \theta_1 - \theta_2)$]