

EE 122 Housekeeping

- ❑ Welcome back. This is 122.
- ❑ Schedule has been changed. Check website.
- ❑ Project phase 2 due on Apr 11
- ❑ Our journey through the layers:
 - Application
 - Transport
 - Network
 - **Link**
 - Physical (Wireless)

DataLink Layer 1

The Data Link Layer

Our goals:

- ❑ understand principles behind data link layer services:
 - error detection, correction
 - sharing a common medium: multiple access
 - link layer addressing
- ❑ discussion of various link layer technologies, particularly the Ethernet
- ❑ 802.11 Wi-Fi and other wireless technologies will be discussed in greater detail later.

DataLink Layer 2

Link Layer

- Introduction and services
- Error detection and correction
- Multiple access protocols
- Link-Layer Addressing
- Ethernet

DataLink Layer 3

Link Layer: Introduction

Some terminology:

- hosts and routers are **nodes**
- communication channels that connect adjacent nodes along communication path are **links**
 - wired links
 - wireless links
 - LANs
- layer-2 packet is a **frame**, encapsulates datagram

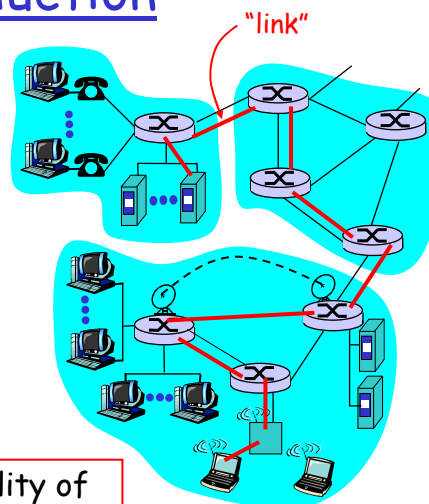

data-link layer has responsibility of transferring datagram from one node to adjacent node over a link

DataLink Layer 4

Link layer: context

- Datagram transferred by different link protocols over different links:
 - e.g., Ethernet on first link, frame relay on intermediate links, 802.11 on last link
- Each link protocol provides different services
 - e.g., may or may not provide rdt over link

Link Layer Services

- **Framing, link access:**
 - encapsulate datagram into frame, adding header, trailer
 - channel access if shared medium
 - "MAC" addresses used in frame headers to identify source, dest
 - different from IP address!
- **Reliable delivery between adjacent nodes**
 - we learned how to do this already (chapter 3)!
 - seldom used on low bit error link (fiber, some twisted pair)
 - wireless links: high error rates
 - Q: why both link-level and end-end reliability?

Link Layer Services (more)

Error Detection and Correction:

- errors caused by signal attenuation, noise.
 - receiver detects presence of errors:
 - signals sender for retransmission or drops frame
 - receiver identifies *and corrects* bit error(s) without resorting to retransmission
- *Half-duplex and full-duplex*
- with half duplex, nodes at both ends of link can transmit, but not at same time

DataLink Layer 7

Adaptors Communicating

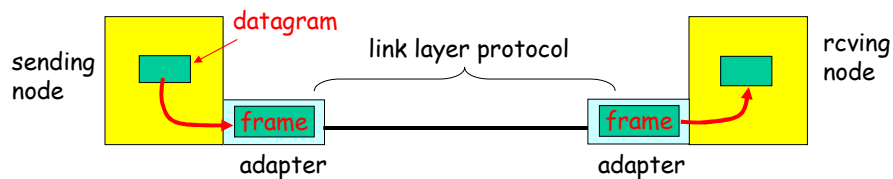

- link layer implemented in "adaptor" (aka NIC)
- Ethernet card, PCMCIA card, 802.11 card
- sending side:
- encapsulates datagram in a frame
 - adds error checking bits, rdt, flow control, etc.
- receiving side
- looks for errors, rdt, flow control, etc
 - extracts datagram, passes to rcving node

DataLink Layer 8

Link Layer

- Introduction and services
- Error detection and correction
- Multiple access protocols
- Link-Layer Addressing
- Ethernet

DataLink Layer 9

Error Detection and Correction

EDC= Error Detection and Correction bits (redundancy)

D = Data protected by error checking, may include header fields

- Error detection not 100% reliable!
 - protocol may miss some errors, but rarely
 - larger EDC field yields better detection and correction

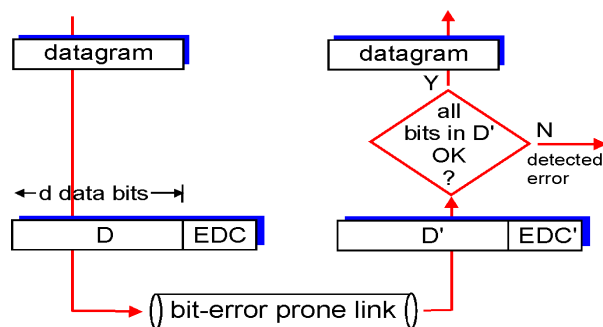

DataLink Layer 10

Parity Checking

Single Bit Parity:

Detect how many errors?

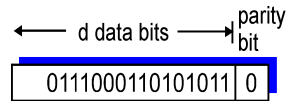

Two Dimensional Bit Parity:

Detect how many bit errors?

Correct how many errors?

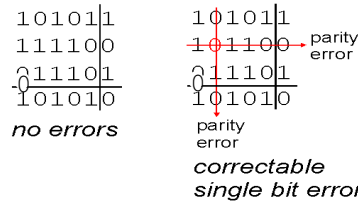
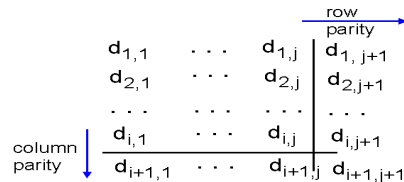

DataLink Layer 11

General Parity-Check Codes

- ❑ A general parity check code adds k parity checks to n data bits
- ❑ Data rate = $n/(n+k)$ information bits per code bits
- ❑ Minimum Hamming distance d is the minimum number of bit flips to get from one possible transmitted sequence (codeword) to another.
- ❑ Can detect if there are less than d errors.
- ❑ Can correct if there are less than $d/2$ errors.
- ❑ Performance under burst errors also important

DataLink Layer 12

Another example: checksum

Goal: detect "errors" (e.g., flipped bits) in transmitted segment (note: used at transport layer *only*)

Sender:

- treat segment contents as sequence of 16-bit integers
- checksum: addition (1's complement sum) of segment contents
- sender puts checksum value into UDP checksum field

Receiver:

- compute checksum of received segment
- check if computed checksum equals checksum field value:
 - NO - error detected
 - YES - no error detected. *But maybe errors nonetheless?*
More later

DataLink Layer 13

Cyclic Redundancy Check (CRC)

- view data bits, D , as a binary number
- choose $r+1$ bit pattern (generator), G (leftmost and rightmost bits are both 1)
- goal: choose r CRC bits, R , such that
 - $\langle D, R \rangle$ exactly divisible by G (modulo 2)
 - receiver knows G , divides $\langle D, R \rangle$ by G . If non-zero remainder: error detected!
 - can detect how many burst errors?
- widely used in link layer technologies

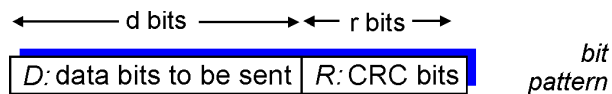

$$D * 2^r \text{ XOR } R \quad \text{mathematical formula}$$

DataLink Layer 14

CRC Example

Want:

$$D \cdot 2^r \text{ XOR } R = nG$$

equivalently:

$$D \cdot 2^r = nG \text{ XOR } R$$

equivalently:

if we divide $D \cdot 2^r$ by G , want remainder R

$$R = \text{remainder} \left[\frac{D \cdot 2^r}{G} \right]$$

