

EE123

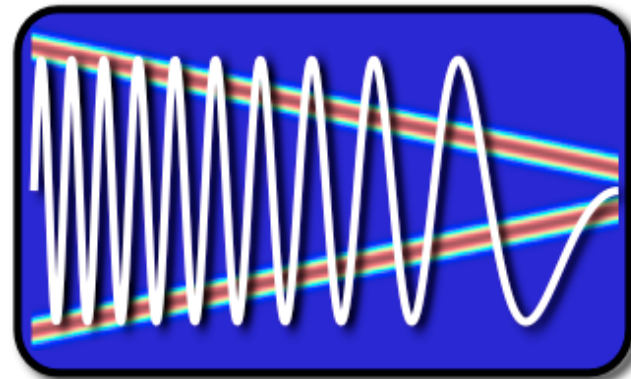

Digital Signal Processing

Lecture 18
Filter Banks

Announcements

- Lab III due Sunday 11:55pm
- HW6 due Monday 11:55pm
- Midterm II Rescheduled Options 3/31 6:30-8:30 or 4/3 2-4 or 3-5
- Ham radio exam this Thursday (!!!)
 - Get your licenses next week
 - Get radios when you get a callsign

Last Time

- Polyphase decomposition

- Today:
 - Multi-rate Filter Banks
 - Subtleties in Time-Frequency tiling
 - Perfect reconstruction with non-ideal filters
 - Polyphase filter banks

Polyphase Decomposition

- We can decomposed an impulse response to:

$$h[n] = \sum_{k=0}^{M-1} h_k[n - k]$$

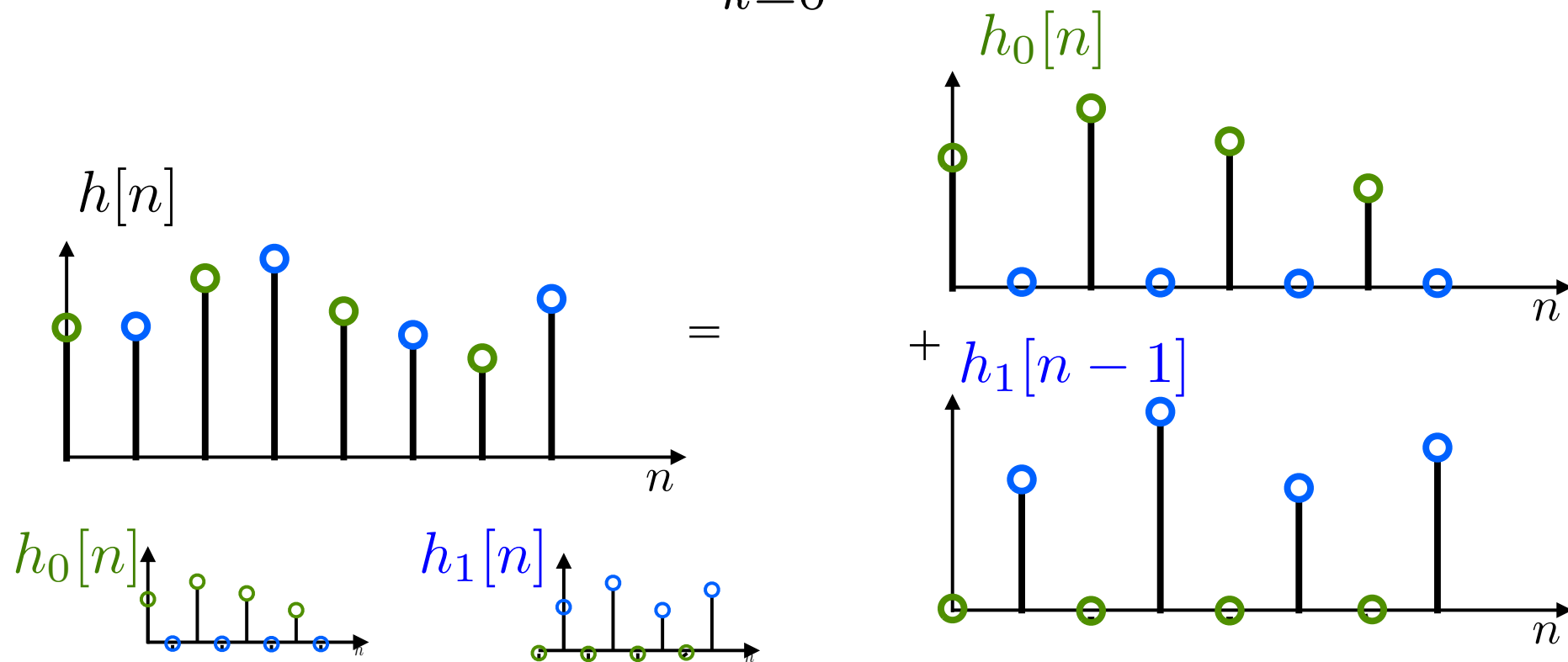

Polyphase Decomposition

- Define:

$$h_k[n] \rightarrow \boxed{\downarrow M} \rightarrow e_k[n]$$

$$e_k[n] = h_k[nM]$$

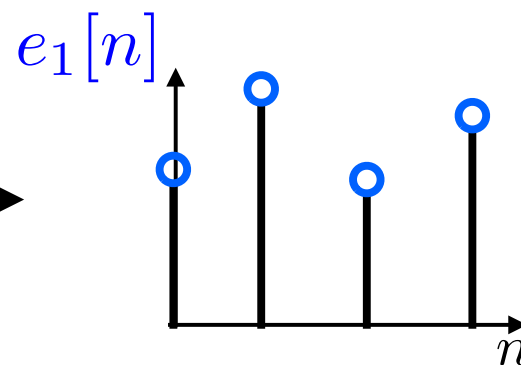
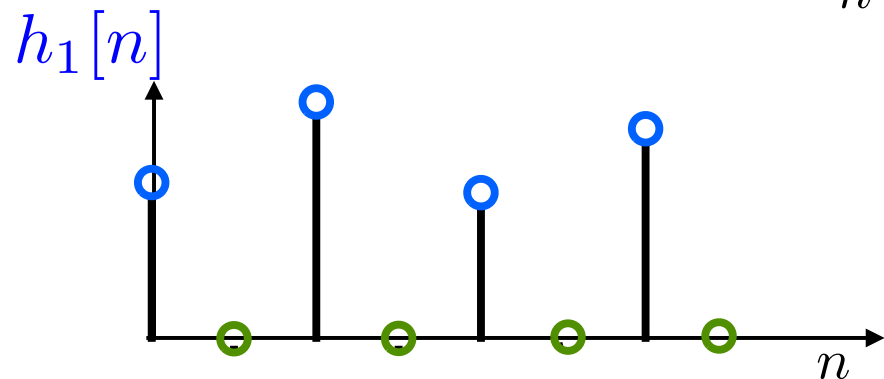
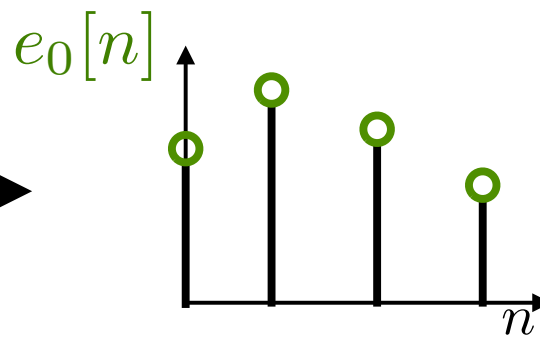
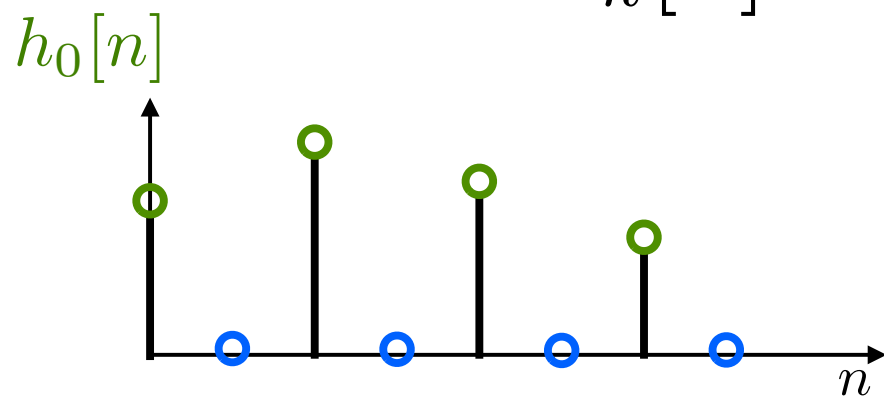

Polyphase Decomposition

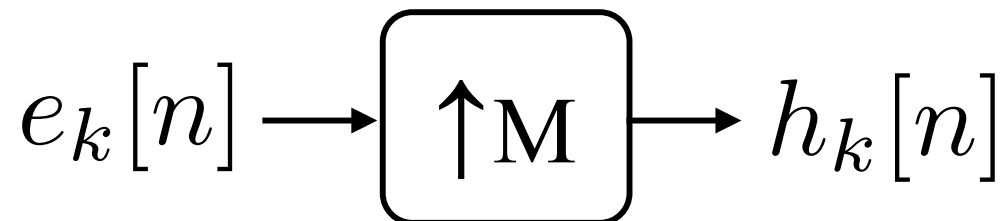

recall upsampling \Rightarrow scaling

$$H_k(z) = E_k(z^M)$$

Also, recall:

$$h[n] = \sum_{k=0}^{M-1} h_k[n - k]$$

So,

$$H(z) = \sum_{k=0}^{M-1} E_k(z^M) z^{-k}$$

Polyphase Decomposition

$$H(z) = \sum_{k=0}^{M-1} E_k(z^M) z^{-k}$$

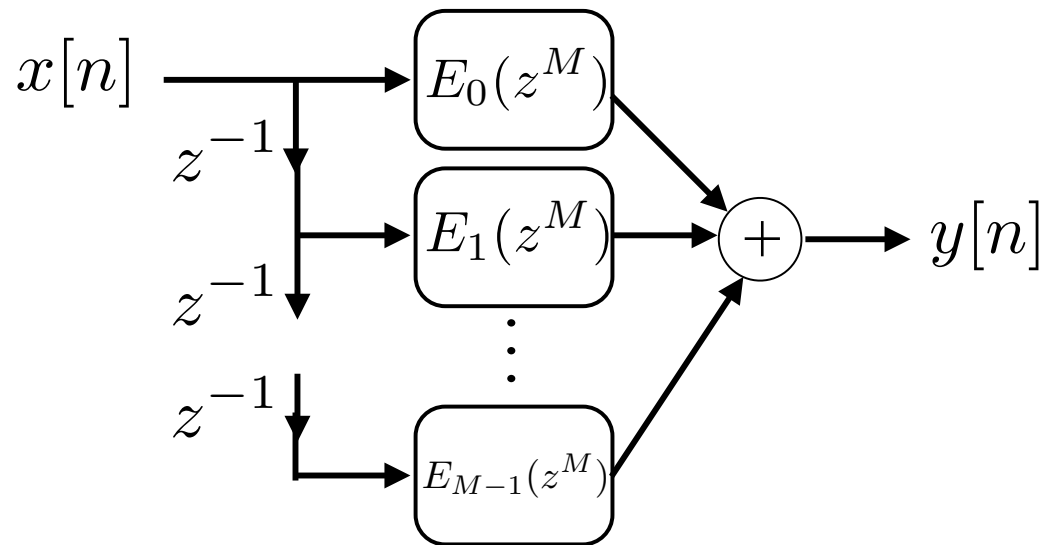

Why should you care?

Polyphase Implementation of Decimation

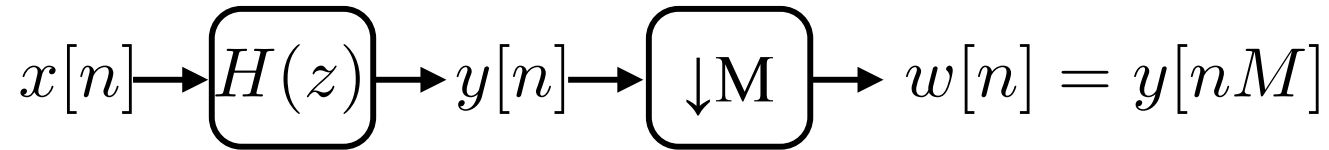

- **Problem:**

- Compute all $y[n]$ and then throw away --
wasted computation!

- For FIR length $N \Rightarrow N$ mults/unit time

- Can interchange Filter with compressor?

- Not in general!

Polyphase Implementation of Decimation

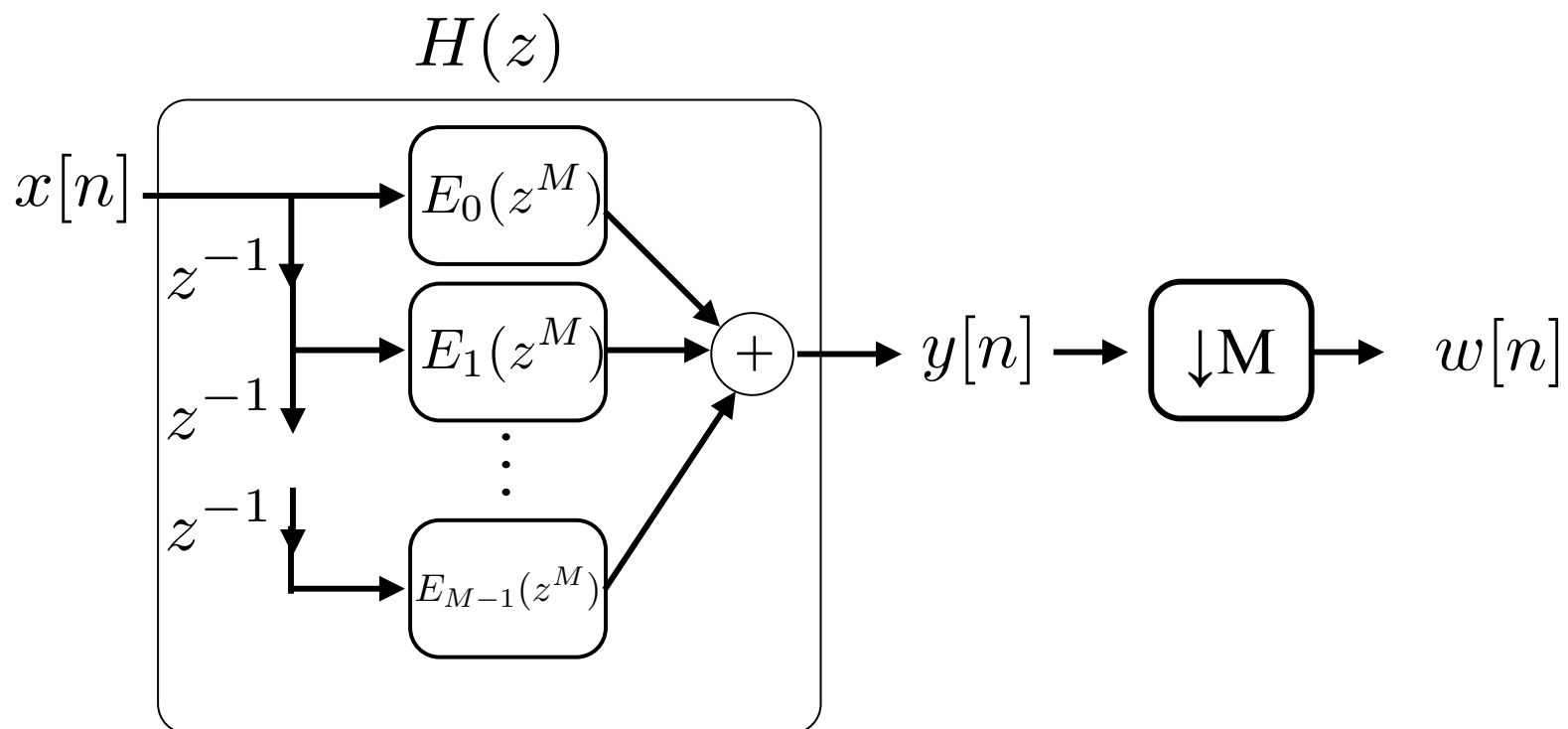
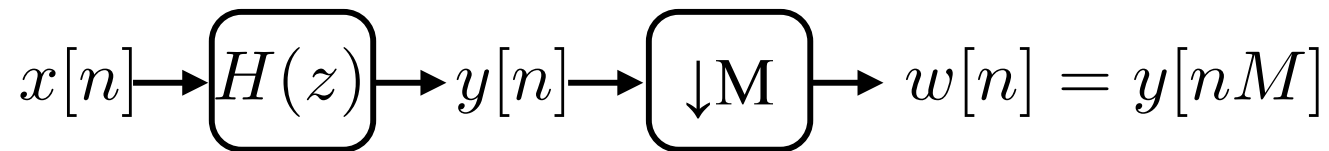

Polyphase Implementation of Decimation

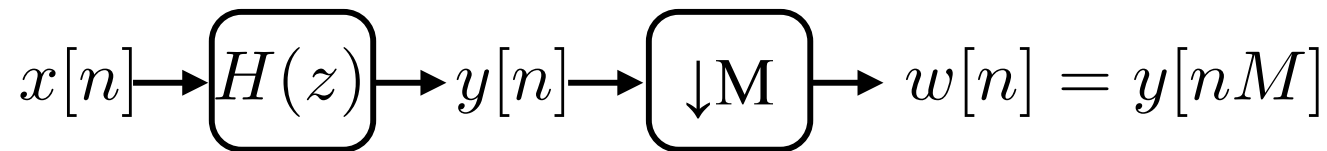

Interchange filter with decimation

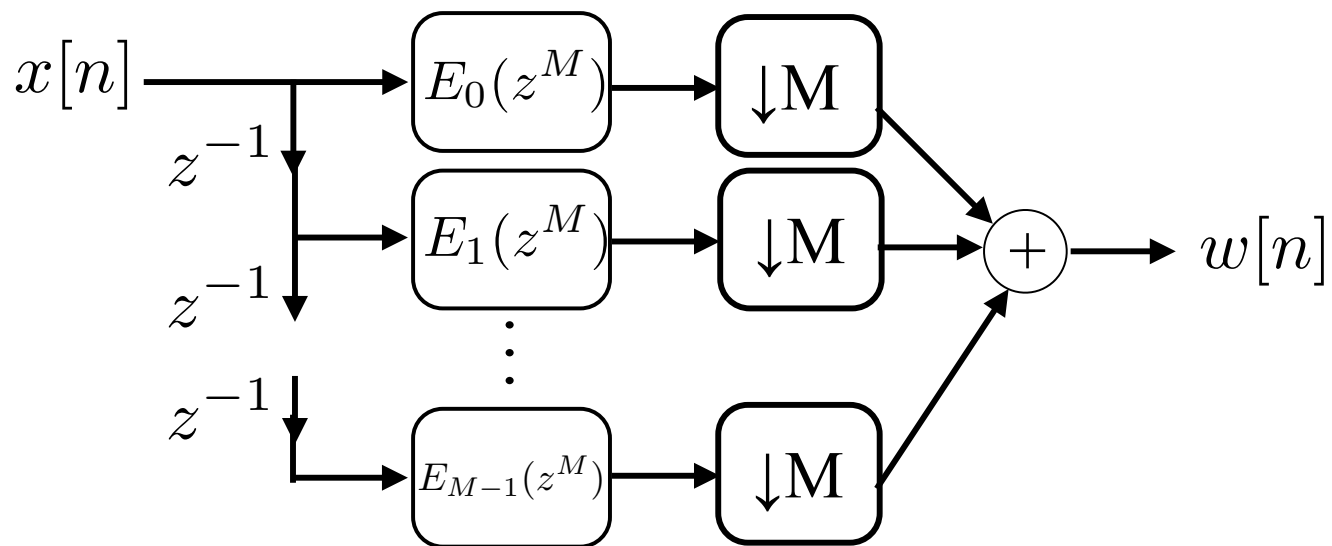

now, what can we do?

Polyphase Implementation of Decimation

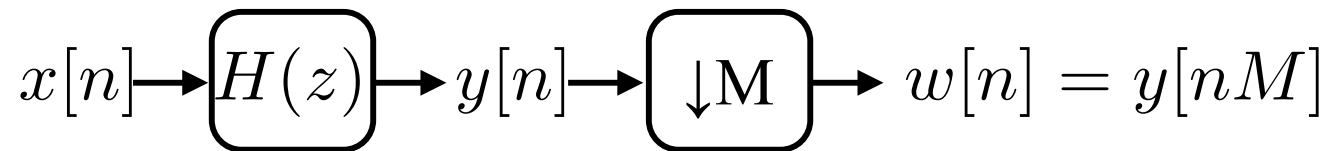

Interchange filter with decimation

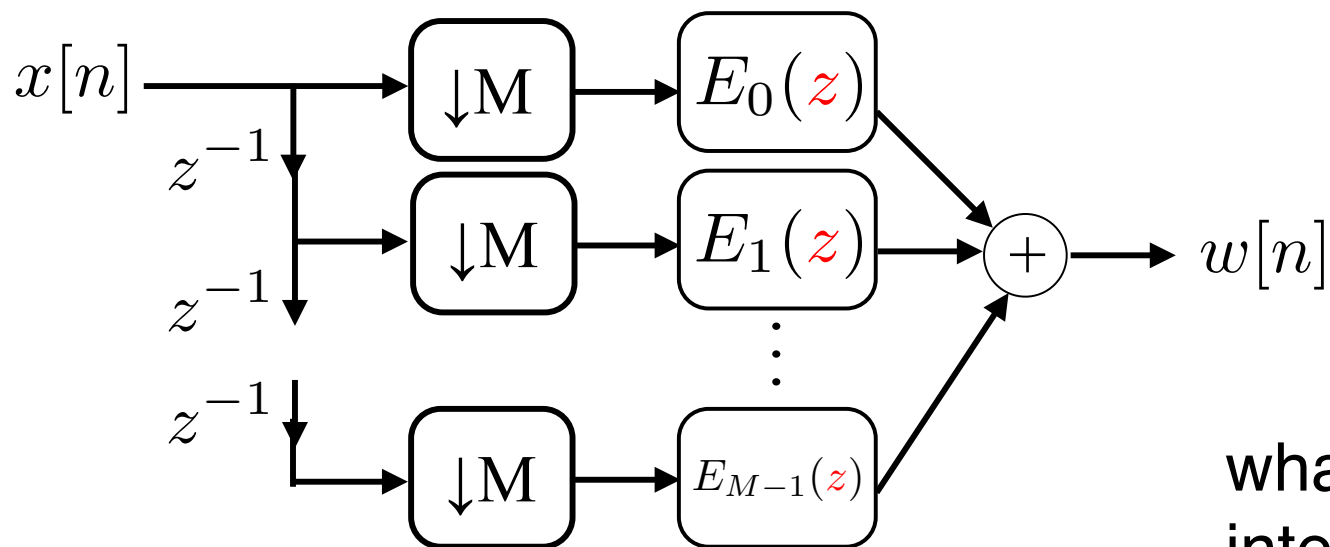

what about interpolation?

Computation:

Each Filter: $N/M * (1/M)$ mult/unit time

Total: N/M mult/unit time

Multirate FilterBank

- $h_0[n]$ is low-pass, $h_1[n]$ is high-pass
- Often $h_1[n] = e^{j\pi n} h_0[n]$ or $H_1(e^{j\omega}) = H_0(e^{j(\omega-\pi)})$

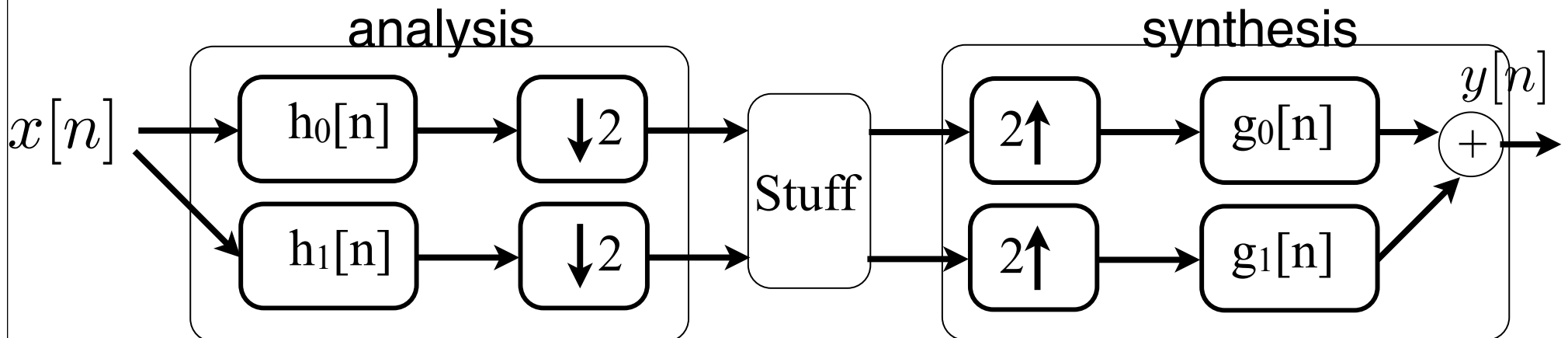

Subtleties in Time-Freq Tiling

- Assume h_0 , h_1 are ideal low,high pass filters

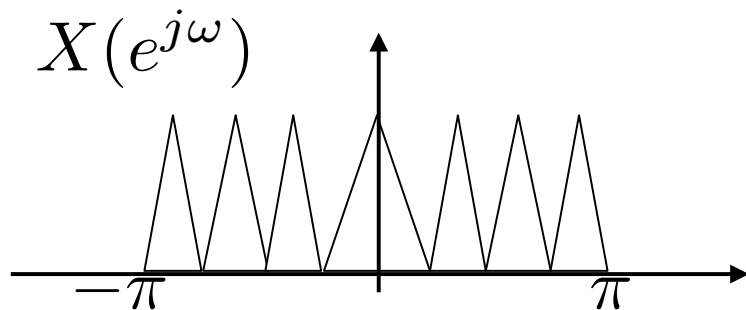
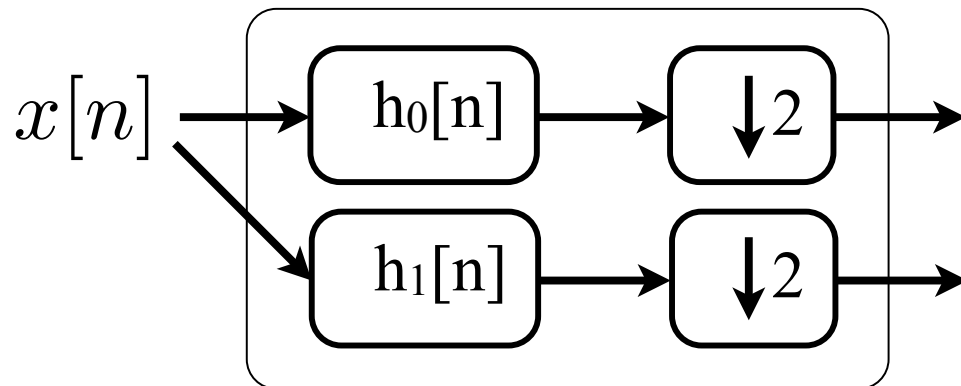

Subtleties in Time-Freq Tiling

- Assume h_0 , h_1 are ideal low,high pass filters

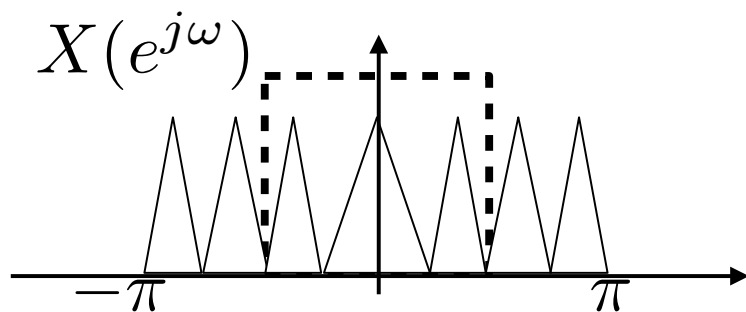
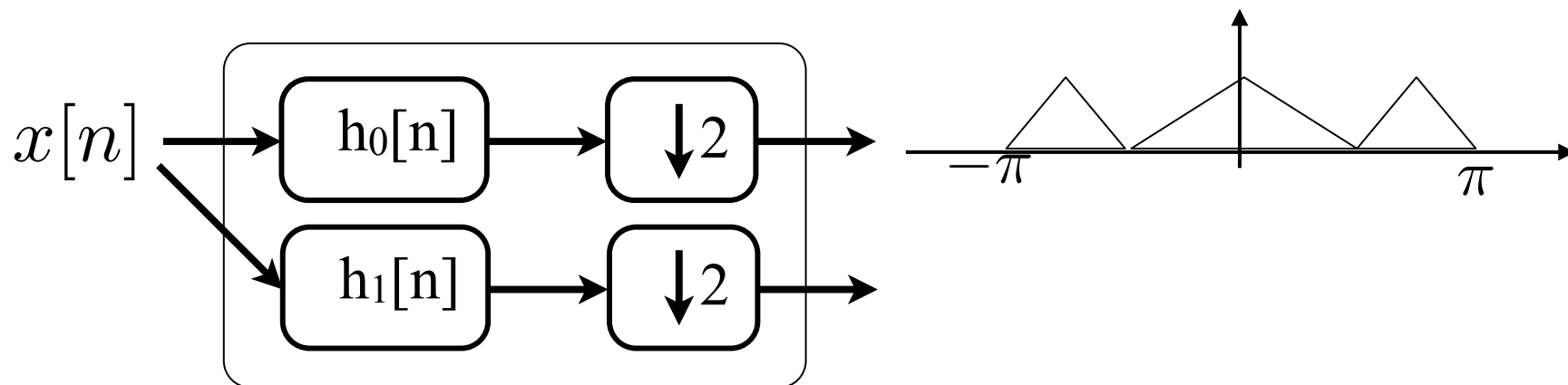

Subtleties in Time-Freq Tiling

- Assume h_0, h_1 are ideal low,high pass filters

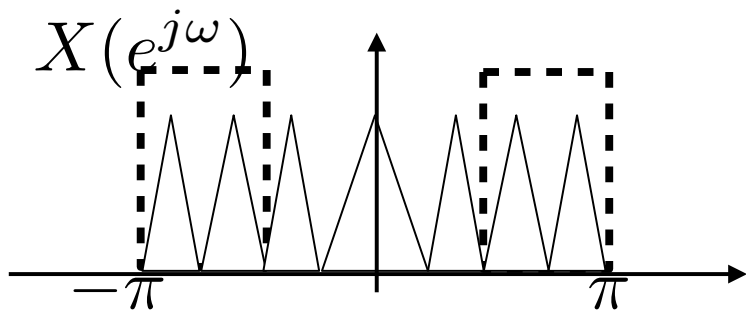
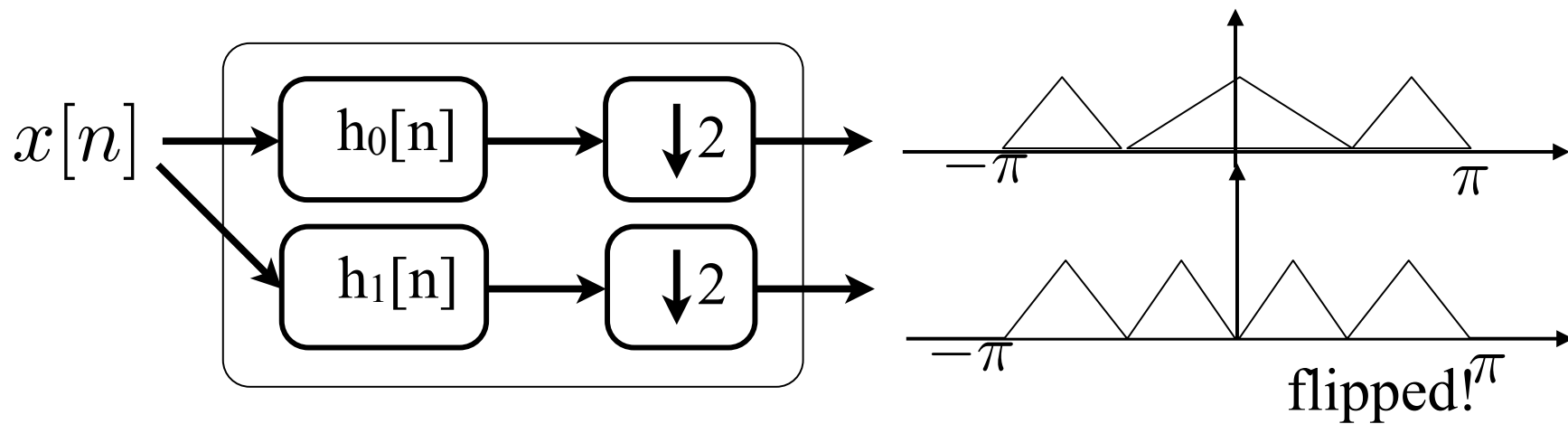

Subtleties in Time-Freq Tiling

- Assume h_0, h_1 are ideal low, high pass filters

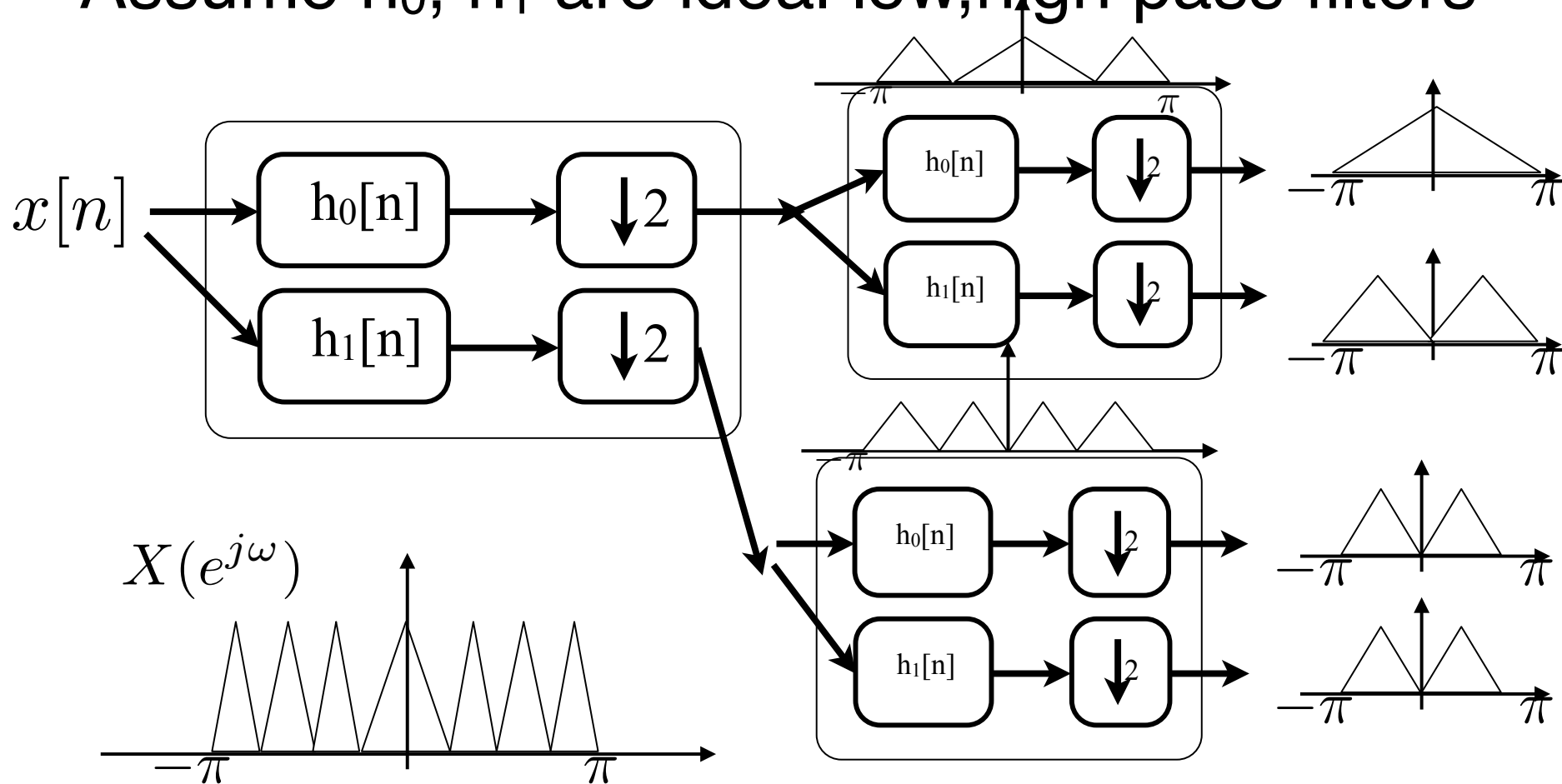

Perfect Reconstruction Ideal Filters

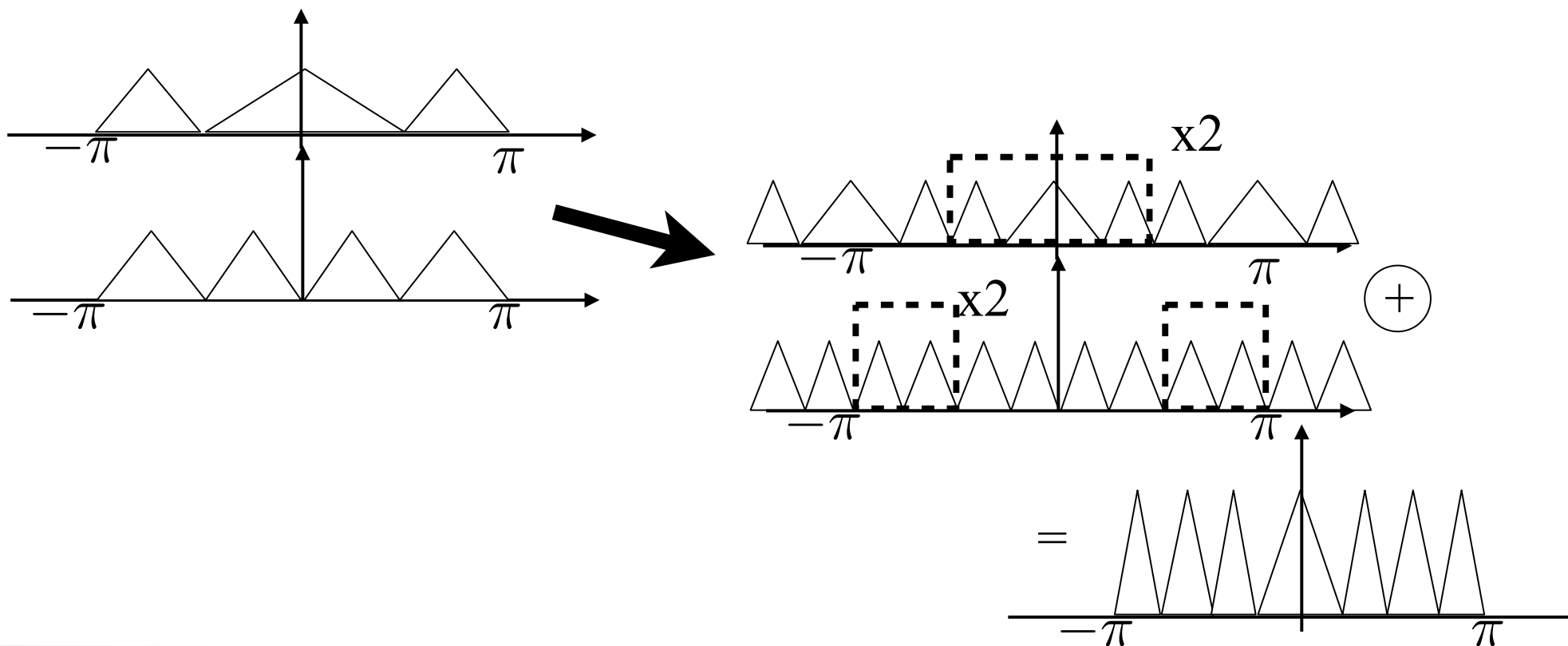
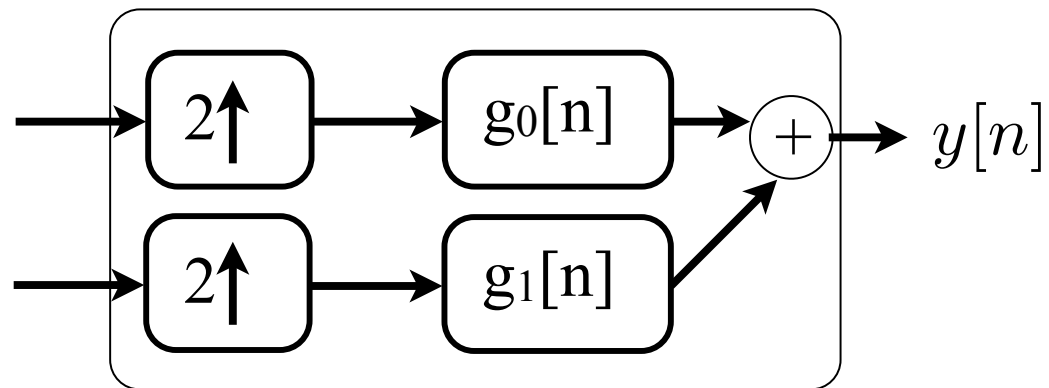

Non ideal LP and HP Filters

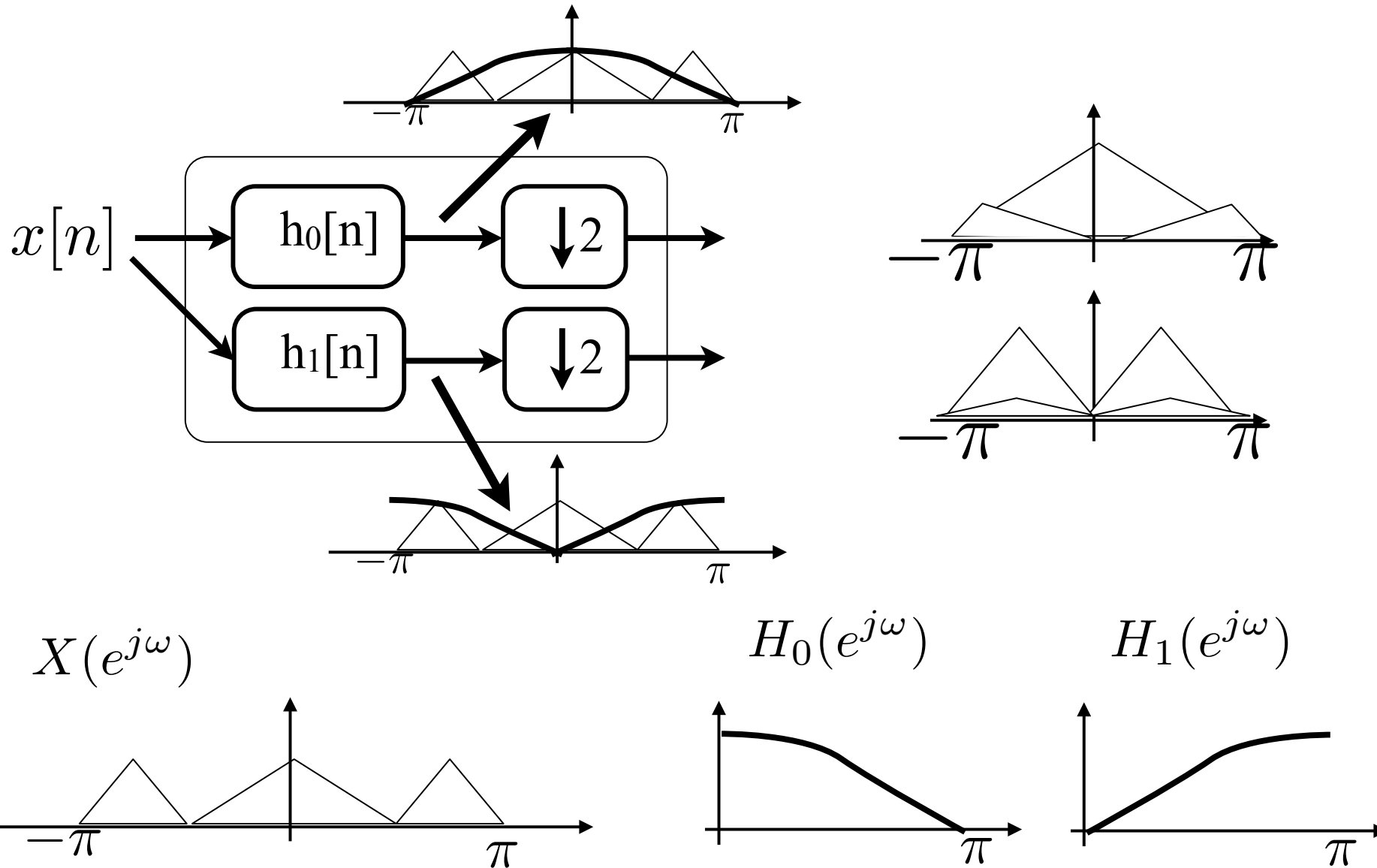

Perfect Reconstruction non-Ideal Filters

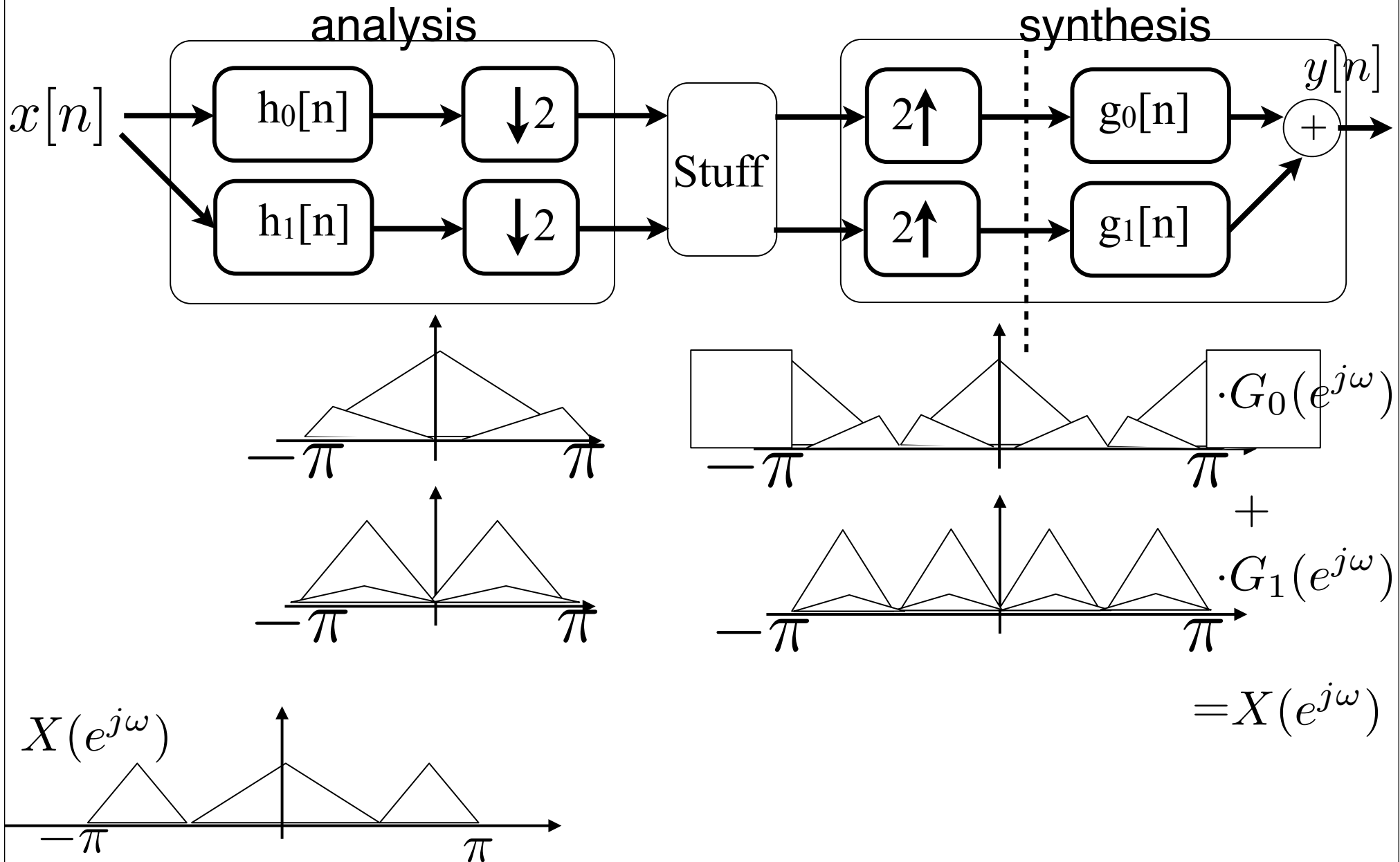

Perfect Reconstruction non-Ideal Filters

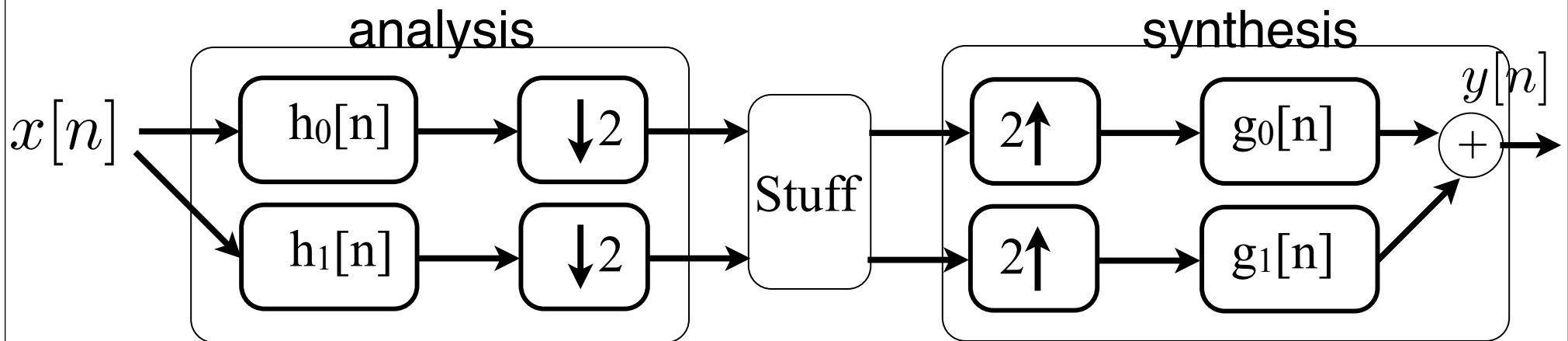

$$Y(e^{j\omega}) = \frac{1}{2} [G_0(e^{j\omega})H_0(e^{j\omega}) + G_1(e^{j\omega})H_1(e^{j\omega})] X(e^{j\omega})$$

$$+ \frac{1}{2} [G_0(e^{j\omega})H_0(e^{j(\omega-\pi)}) + G_1(e^{j\omega})H_1(e^{j(\omega-\pi)})] X(e^{j(\omega-\pi)})$$

↑
need to cancel!

↑
aliasing

Quadrature Mirror Filters - perfect recon

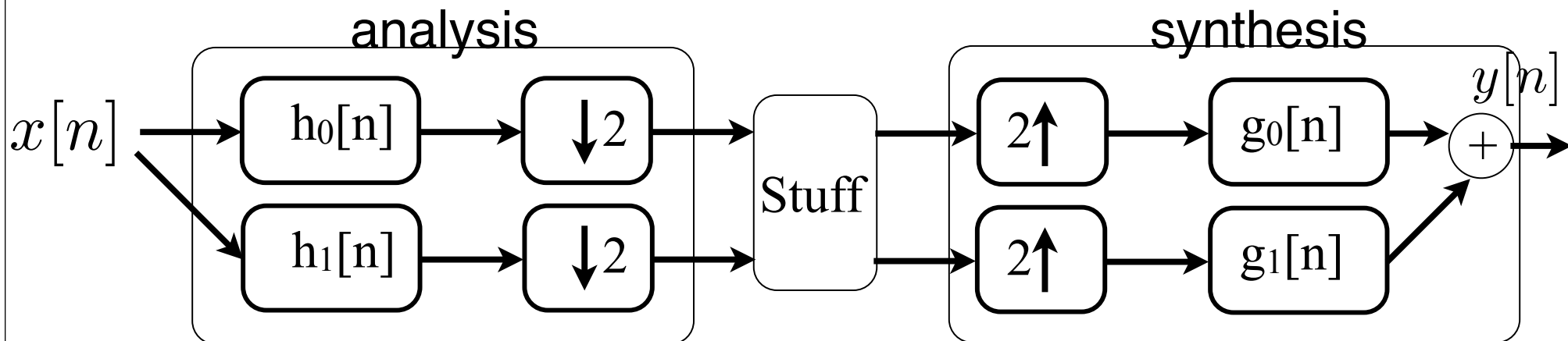

QMF - mirror around $\pi/2$

$$H_1(e^{j\omega}) = H_0(e^{j(\omega-\pi)})$$

$$G_0(e^{j\omega}) = 2H_0(e^{j\omega})$$

$$G_1(e^{j\omega}) = -2H_1(e^{j\omega})$$

Quadrature Mirror Filters - perfect recon

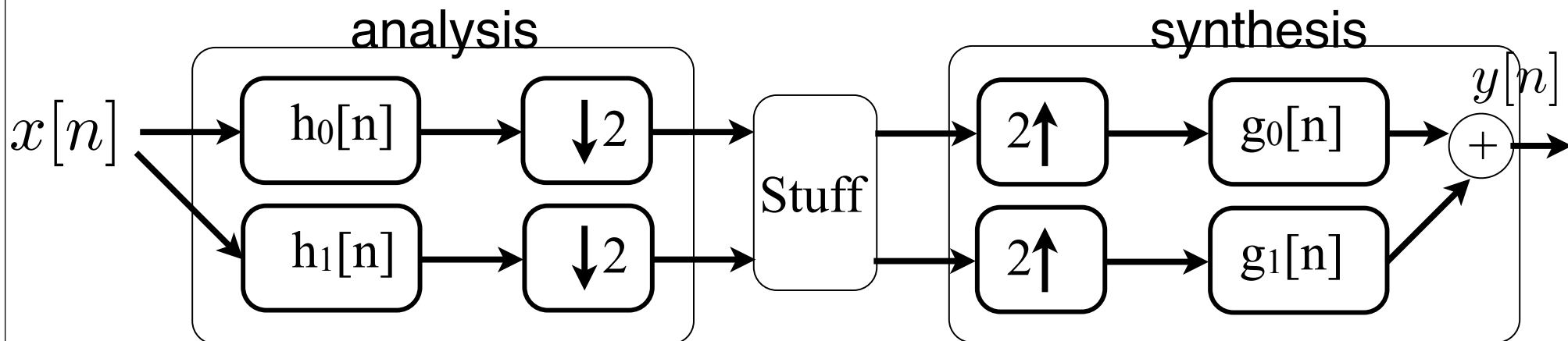

QMF - mirror around $\pi/2$

$$H_1(e^{j\omega}) = H_0(e^{j(\omega-\pi)})$$

$$G_0(e^{j\omega}) = 2H_0(e^{j\omega})$$

$$G_1(e^{j\omega}) = -2H_1(e^{j\omega})$$

Example Haar:

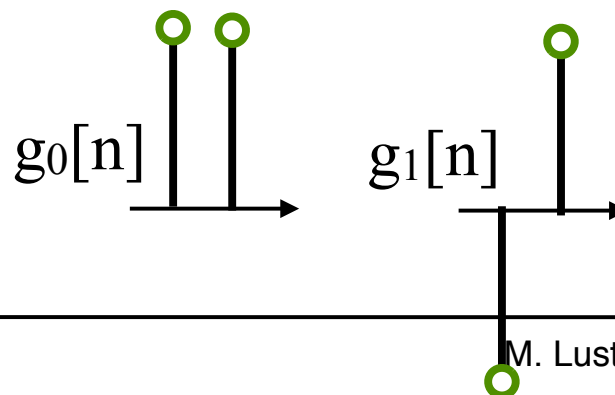
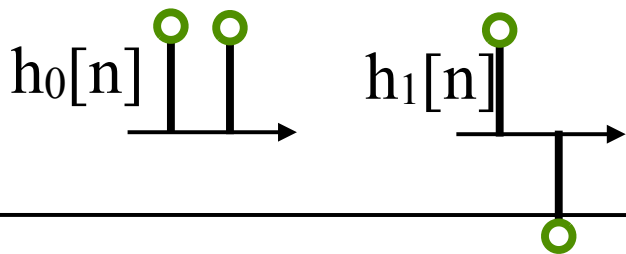

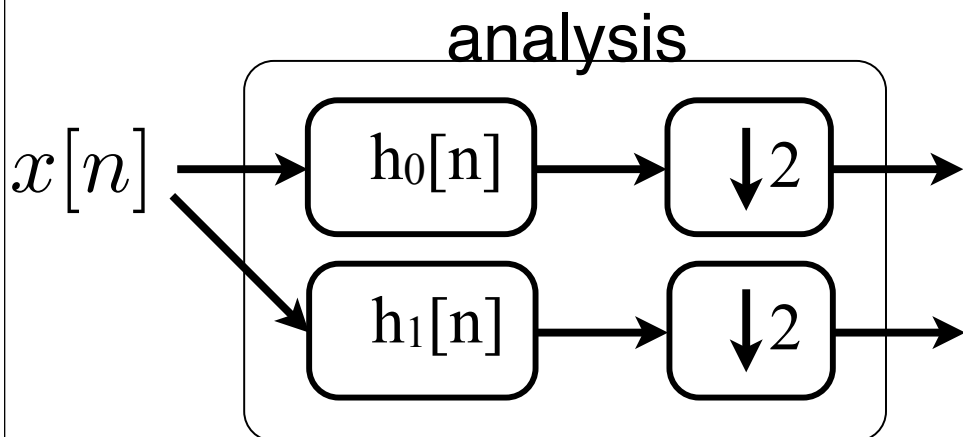

$$e_{00} = h_0[2n]$$

$$e_{01} = h_0[2n + 1]$$

$$e_{10} = h_1[2n] = e^{j2\pi n} h_0[2n] = e_{00}[n]$$

$$e_{11} = h_1[2n + 1] = e^{j2\pi n} e^{j\pi} h_0[2n + 1] = -e_{01}[n]$$

Polyphase Filter-Bank

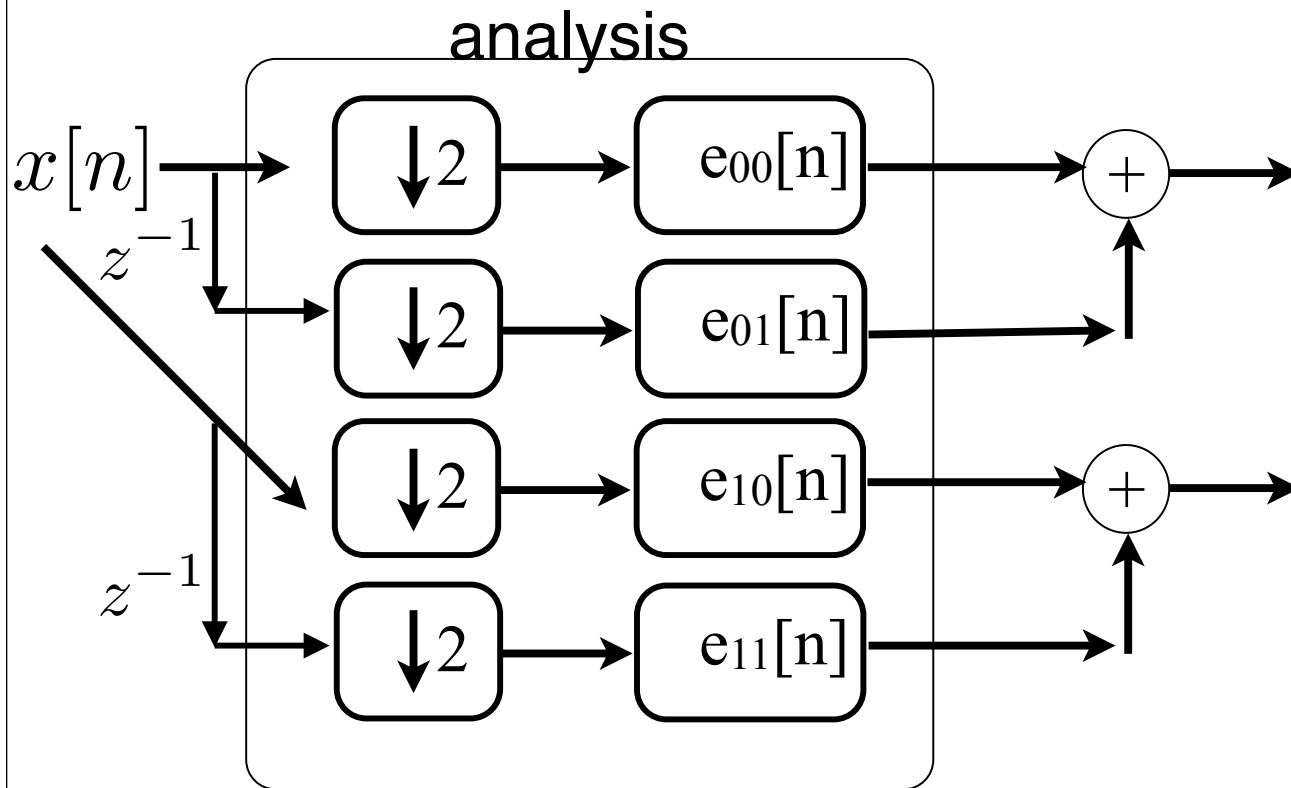

$$e_{00} = h_0[2n]$$

$$e_{01} = h_0[2n + 1]$$

$$e_{10} = e_{00}[n]$$

$$e_{11} = -e_{01}[n]$$

Polyphase Filter-Bank

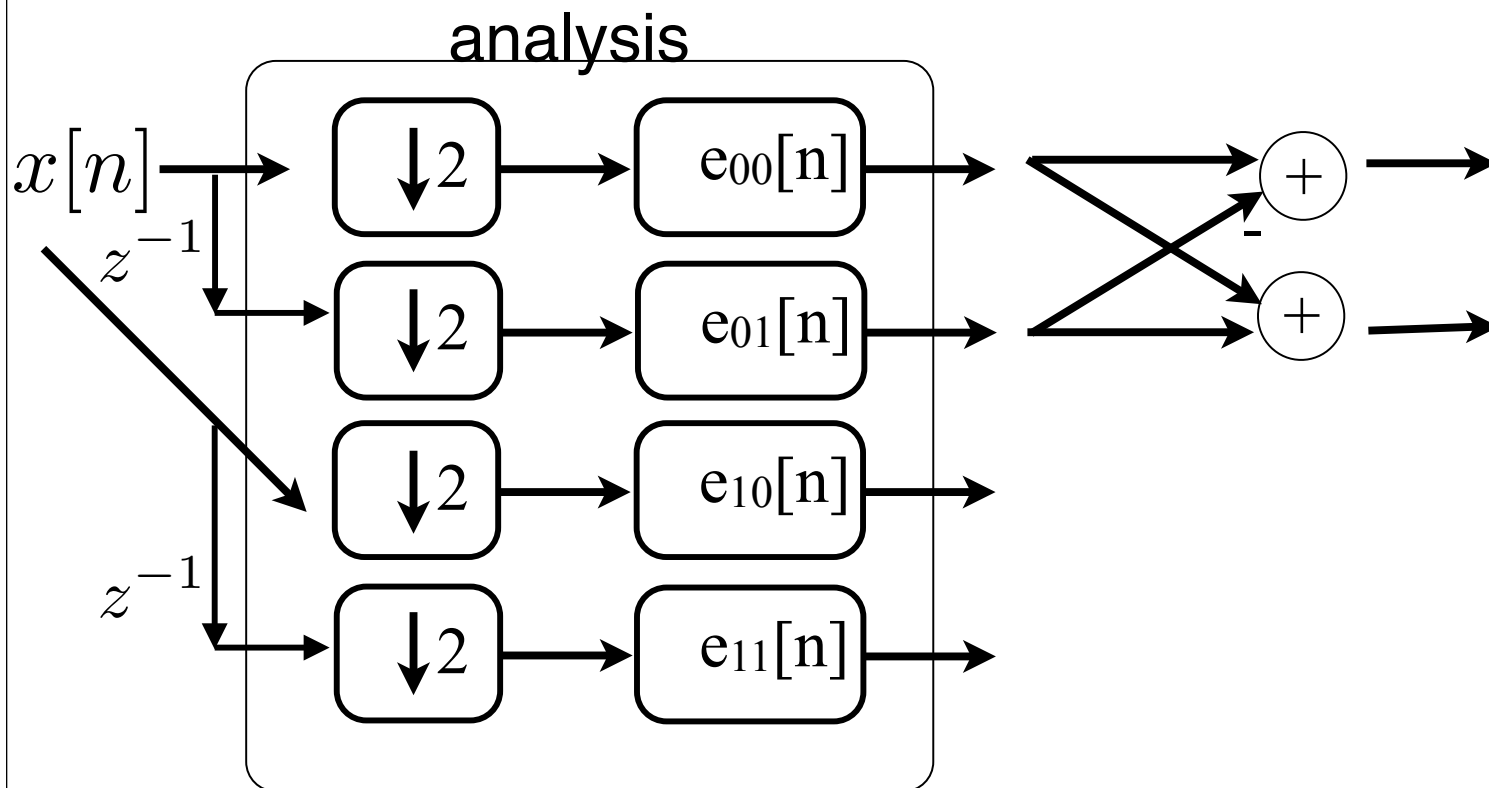

$$e_{00} = h_0[2n]$$

$$e_{01} = h_0[2n + 1]$$

$$e_{10} = e_{00}[n]$$

$$e_{11} = -e_{01}[n]$$