CS 152 Laboratory Exercise 5

*Professor: Sophia Shao
Department of Electrical Engineering & Computer Sciences
University of California, Berkeley*

April 18, 2023

Revision History

Revision	Date	Author(s)	Description
1.1	2023-04-18	Jamie Hong	Update setup and spec
1.0	2022-04-08	hngenc	Initial release

1 Introduction and Goals

The goal of this laboratory assignment is to allow you to explore shared memory multi-processor systems using the Chisel simulation environment. You will be provided a complete implementation of a dual-core Rocket processor supporting the RV64GC ISA. You will write multi-threaded C programs to gain a better understanding of how data-level parallel (DLP) code maps to multi-core processors and to practice optimizing code for different cache coherence protocols.

While students are encouraged to discuss solutions to the lab assignments with each other, you must complete the directed portion of the lab yourself and submit your own work for these problems. For the open-ended portion of each lab, students can either work individually or in groups of two or three. Each group will turn in a single report for the open-ended portion of the lab. You are free to participate in different groups for different lab assignments.

1.1 Graded Items

All code and reports are to be submitted through **Gradescope**. Please label each section of the results clearly. All directed items need to be turned in for evaluation.

- (Directed) Problem 3.3: Naive `vvadd` results for MSI
- (Directed) Problem 3.4: Naive `vvadd` results for MI and analysis
- (Directed) Problem 3.5: Optimized `vvadd` code, results, and analysis

- (Open-ended) Problem 4: Optimized `matmul` code, results, and analysis
- (Directed) Problem 5: Feedback

2 Background

2.1 Dual-Core Rocket Processor

Rocket will be returning from Lab 2, but this time, there are two Rocket cores.

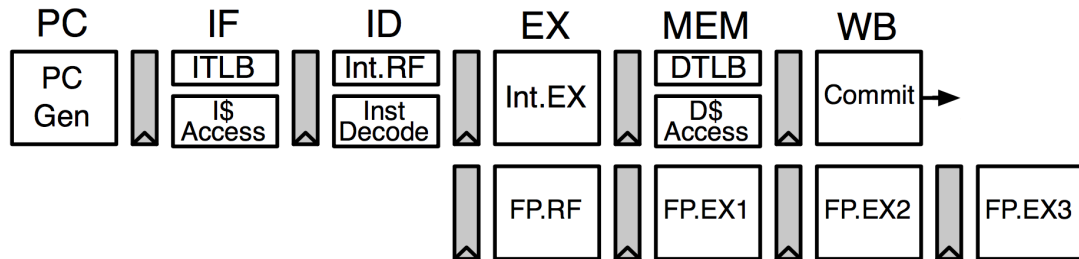

Figure 1: Rocket pipeline

Rocket is a 5-stage, single-issue, fully-bypassed, in-order RISC-V core. The configurations used in this lab implement the RV64IMAFDC instruction set variant¹, which refers to the 64-bit RISC-V base ISA (RV64I) along with a set of useful extensions [1]: M for integer multiply/divide, A for atomic memory operations, F and D for single- and double-precision floating-point, and C for 16-bit compressed representations of common instructions

Rocket also supports the RISC-V privileged architecture [2] with machine, supervisor, and user modes. It has an MMU that implements the Sv39 virtual memory scheme, which provides 39-bit virtual address spaces with 4 KiB pages. These processors are fully capable of booting mainstream operating systems such as Linux; however, no OS will be used in this lab, so code will run “bare metal” in M-mode.

2.2 Memory System

In this lab, you are provided with a dual-core system that utilizes a snoopy cache coherence protocol. Figure 2 shows the high-level block diagram.

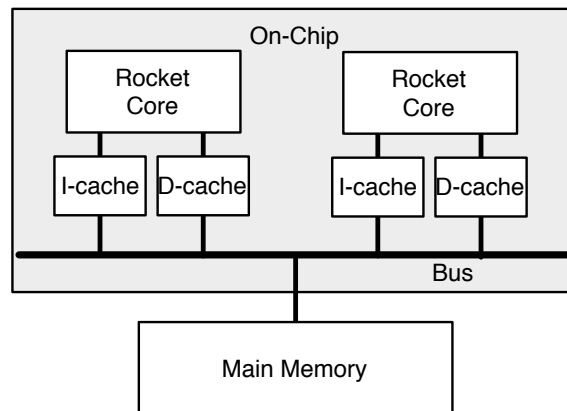

¹ Also known as RV64GC, with G (“general-purpose”) being the canonical shorthand for “IMAFD”

Figure 2: The dual-core Rocket system. A *logical* bus connects the caches and main memory. In practice, the bus is implemented as a crossbar with a coherence hub that arbitrates access to the “bus,” initiates coherence “probe” traffic across the bus, and orchestrates the cache coherence protocol.

Each Rocket core has its own private L1 caches:

- 16 KiB 4-way set-associative L1 instruction cache
- 4 KiB 4-way set-associative L1 data cache

The data caches are kept *coherent* with one another.

An off-chip memory provides the last level of the memory hierarchy. Both cores are connected via a bus to main memory, which is backed by a DRAM model that simulates the functional and timing behaviors of a DDR3 memory system. Only one agent may access the bus at a time.

Conceptually, cache coherence is maintained by having caches broadcast their intentions across the bus and “snooping”, or monitoring, the actions of the other caches.

2.3 Multi-threaded Programming Environment

In most conventional multi-threaded programming environments, one thread begins execution at `main()`, which must then call some sort of `spawn` or `clone()` function to create more threads with assistance from the operating system.

In contrast, we will not be using an OS in this lab. Instead, *all* threads enter `main()` roughly simultaneously after a designated “boot” thread finishes initializing the C runtime environment. Each thread is provided with `ncores` (the number of cores in the system) and a `coreid` (a unique numerical identifier from 0 to `ncores - 1`, inclusive).

2.3.1 Memory Allocation

You will need to be careful how you allocate memory in your code. Local variables can be allocated on the stack as usual; however, each thread is reserved only a limited amount of stack space. You will want to use the `static` keyword to allocate variables statically in the executable image, where it is visible to all threads.

There is also the `__thread` storage class keyword, which denotes a thread-specific variable that should be located in *thread-local storage* (TLS). TLS is a mechanism by which each thread is given its own private instance of the variable. It requires significant orchestration between the linker and system libraries to work, but this complexity is largely transparent to user code.²

2.3.2 Synchronization Primitives

In the software framework, a `barrier()` function is provided to synchronize threads. Once a thread reaches the `barrier()` function, it waits until all threads in the system have reached the same `barrier()`. Implicit in the barrier is a memory fence. The `barrier()` function should probably be sufficient to implement any algorithm necessary in this lab. For more information on the RISC-V memory ordering instructions, consult Section 2.7 of the user-level ISA manual [1]. Section 14 defines the RVWMO (RISC-V weak memory ordering) memory consistency model. Appendix A offers a more in-depth explanation of the rationale behind RVWMO.

²<http://people.redhat.com/drepper/tls.pdf>

The RISC-V `fence` instruction can be inserted in C code using the `__sync_synchronize()` GCC built-in function (saving you the hassle of inlining assembly). The GCC compiler provides more built-in functions for atomic memory accesses, such as `__sync_fetch_and_add()`.³

The `fence` instruction behaves as follows: If the data cache is not busy, the `fence` immediately retires, the pipeline continues execution. If the cache is busy servicing outstanding memory requests (i.e., cache misses), the `fence` stalls the pipeline until the cache is no longer busy. In this manner, the `fence` instruction ensures that all memory operations *before* the fence have completed before any memory operations *after* the fence are issued.⁴

2.3.3 Warnings and Pitfalls

- The stack space provided to each thread is only 24 KiB. As there is no virtual memory protection, there will be no warning if you overrun your stack. Try to allocate arrays and other large data structures statically.
- `printf()` can be used to debug your code. However, it is up to you to ensure that it is called by only one thread at a time; otherwise, the output may be incomprehensibly interleaved. Also, the `printf` implementation in this lab (provided by a stripped-down version of `newlib`, an embedded C library) does not support formatting floating-point types. You will have to cast them to integer types first. However, you will note that the randomly generated test vectors are actually using whole numbers for convenience.

³https://gcc.gnu.org/onlinedocs/gcc/_005f_005fsync-Builtins.html

⁴Finer-grained fences can be performed by setting the *predecessor* and *successor* fields in the instruction, which define which types of accesses (memory reads, memory writes, device reads, device write) should be ordered.

3 Directed Portion (25%)

3.1 General Methodology

This lab will focus on writing multi-threaded C code. This will be done in two steps:

1. Build the Verilog cycle-accurate emulator of the dual-core processor (if the cache coherence protocol needs to be changed)
2. Verify the correctness and measure the performance of your code on the cycle-accurate emulator

3.2 Setup

To complete this lab, `ssh` into an instructional server with the instructional computing account provided to you. The lab infrastructure has been set up to run on the `eda{1..8}.eecs.berkeley.edu` machines (`eda-1.eecs`, `eda-2.eecs`, etc.).

Once logged in, source the following script to initialize your shell environment so as to be able to access to the tools for this lab. Run it before each session.

```
eecs$ source ~cs152/sp23/cs152.lab5.bashrc
```

First, clone the lab materials into an appropriate workspace and initialize the submodules.

```
eecs$ mkdir /scratch/$USER
eecs$ cd /scratch/$USER
eecs$ git clone ~cs152/sp23/lab5.git
eecs$ cd lab5
eecs$ LAB5ROOT="$(pwd)"
eecs$ ./scripts/init-submodules-no-riscv-tools.sh
```

The remainder of this lab will use `${LAB5ROOT}` to denote the path of the `lab5` working tree. Its directory structure is outlined below:

<code>\${LAB5ROOT}</code>	
<code>lab/</code>	Benchmark source code
<code>mt-vvadd-naive/</code>	Naive vvadd code
<code>mt-vvadd-opt/</code>	Optimized vvadd code
<code>mt-matmul-naive/</code>	Naive matmul code
<code>mt-matmul-opt/</code>	Optimized matmul code
<code>generators/</code>	Library of RTL generators
<code>chipyard/</code>	SoC configurations
<code>rocket-chip/</code>	Rocket Chip generator
<code>testchipip/</code>	RTL blocks for interfacing with test chips
<code>...</code>	
<code>sims/</code>	
<code>verilator/</code>	Verilator simulation flow
<code>vcs/</code>	Synopsys VCS simulation flow
<code>...</code>	
<code>tools/</code>	
<code>chisel3/</code>	Chisel hardware description library
<code>firrtl/</code>	RTL intermediate representation library
<code>barstools/</code>	Collection of common FIRRTL transformations
<code>...</code>	

3.3 Measuring Vector-Vector Add with MSI Coherence

First, to acclimate ourselves to the Lab 5 infrastructure, we will gather the results of a poorly written implementation of `vvadd`, which performs a simple vector-vector addition. Navigate to the `/${LAB5ROOT}/lab/mt-vvadd-naive` directory, which has a few files of interest. First, `dataset.h` holds a static copy of the input vectors and expected results vector.⁵ Second, `mt-vvadd_main.c` contains code for managing the benchmark, which includes initializing the state of the program, calling the `vvadd` function itself, and verifying the output of the function. Lastly, a very poor implementation of multi-threaded `vvadd` can be found in `mt-vvadd_naive.c`.

Build the simulator and run the `mt-vvadd-naive` benchmark on a dual-core configuration with an MSI coherence policy.

```
eecs$ cd ${LAB5ROOT}/sims/verilator
eecs$ make CONFIG=Lab5MSIDualRocketConfig run-mt-vvadd-naive
```

`make` will automatically rebuild the simulator and benchmarks programs if changes to the sources are detected. The `CONFIG` variable instructs the generator to use the configuration with two cores and MSI coherence.

Note that the first time you build `Lab5MSIDualRocketConfig` and `Lab5MIDualRocketConfig`, it will take a while for `verilator` to build the configurations. However, after the first time, running the `make` commands should take much faster.

You should see something similar to the following output for `mt-vvadd-naive`, which comes from timing a section of code that calls the `vvadd_naive()` function:

```
vvadd_naive: 37481 cycles, 37.4 cycles/iter, 8.2 CPI
```

! → *Note what the suboptimal `mt-vvadd-naive` results are with the MSI coherence protocol. This will serve as a good reference point when you begin optimizing the performance of the vector-vector add.*

3.4 Measuring Vector-Vector Add with MI Coherence

Run the `mt-vvadd-naive` benchmark again but using an MI coherence policy.

```
eecs$ cd ${LAB5ROOT}/sims/verilator
eecs$ make CONFIG=Lab5MIDualRocketConfig run-mt-vvadd-naive
```

! → *Note what the `mt-vvadd-naive` results are with the MI coherence protocol. This will serve as a good reference point when you begin optimizing the performance of the vector-vector add.*

Some things to consider:

Taking into account that the code is executed on a multi-core cache-coherent system, consider the naive implementation in `textttvvadd_naive()`. Why is it suboptimal on MI and MSI? What are some potential changes you could make to improve the performance?

3.5 Optimizing Multi-Threaded Vector-Vector Add

Now that you know how to run benchmarks, gather performance results, and change the cache coherence protocol, you can now optimize `vvadd` for the dual Rocket cores.

⁵ For rapid testing, you can generate your own input arrays that are a smaller size using `mt-vvadd_`

Write your code in the `vvadd_opt()` function found in `/${LAB5ROOT}/lab/mt-vvadd-opt/mt-vvadd_opt.c`, and then run the `mt-vv-addopt` benchmark as follows.

```
eecs$ cd ${LAB5ROOT}/sims/verilator
eecs$ make CONFIG=Lab5MIDualRocketConfig run-mt-vvadd-opt
eecs$ make CONFIG=Lab5MSIDualRocketConfig run-mt-vvadd-opt
```

! → *Try seeing what results you get for your optimized implementation with both the MI and MSI protocols. What did you do differently to achieve better performance over the naive `vvadd`? You should be able to reduce the number of cycles per iteration to about 60% of the naive implementation under MSI.*

3.5.1 Submission

Use the following command to prepare your code for submission, and upload the resulting `mt-vvadd.zip` file to the Gradescope autograder.

```
eecs$ cd ${LAB5ROOT}/lab
eecs$ make zip-vvadd
```

Note that code outside of `mt-vvadd_opt.c` will be ignored.

There is no written section for the directed portion that you need to submit.

3.5.2 Vector-Vector Add Tips

Refer back to Section 2.3.3 for potential pitfalls with programming in this bare-metal environment. Remember that you can use `printf()` for debugging, with caveats: Floating-point values are not supported, and make sure only one thread calls `printf()` at a time. The benchmark prints the contents of the `output_data` and `verify_data` arrays if a mismatch is found.

To see what each core is doing cycle by cycle, look at the trace in `/${LAB5ROOT}/sims/verilator/output/chipyard.TestHarness.*/mt-vvadd-opt.riscv.out`, where `*` is the chosen `CONFIG`. The output from core 0 and core 1 is prefixed with `C0:` and `C1:`, respectively. The disassembly in `/${LAB5ROOT}/lab/mt-vvadd-opt.riscv.dump` may be useful for understanding the trace.

You can force `make` to repeat the simulation by manually removing the `mt-vvadd-opt.riscv.out` file from the simulator output directory.

If you encounter an error, you can first debug your code in the ISA-level simulator.

```
eecs$ cd ${LAB5ROOT}/lab
eecs$ make
eecs$ spike -p2 mt-vvadd-opt.riscv
```

The `-p` option sets the number of simulated hardware threads.

Note that `spike` is **not** a cycle-accurate processor model, and the “performance” numbers can be distorted since the hardware threads do not execute concurrently (unlike our actual system) but are switched after 5000 instructions. Also, this coarse-grained interleaving does not expose every race condition that would be possible on hardware.

`gendata.py`.

4 Open-Ended Portion: Optimizing Multi-Threaded Matrix Multiply (75%)

For this problem, you will implement and optimize a multi-threaded version of matrix-matrix multiply.

A naive implementation can be found in `/${LAB5ROOT}/lab/mt-matmul-naive/mt-matmul_naive.c`. First build and run the `mt-matmul-naive` benchmark to measure the baseline performance.

```
eecs$ cd ${LAB5ROOT}/sims/verilator
eecs$ make CONFIG=Lab5MIDualRocketConfig run-mt-matmul-naive
eecs$ make CONFIG=Lab5MSIDualRocketConfig run-mt-matmul-naive
```

Write your code in the `matmul_opt()` function found in `/${LAB5ROOT}/lab/mt-matmul-opt/mt-matmul_opt.c`, and then run the `mt-matmul-opt` benchmark as follows.

```
eecs$ make CONFIG=Lab5MIDualRocketConfig run-mt-matmul-opt
eecs$ make CONFIG=Lab5MSIDualRocketConfig run-mt-matmul-opt
```

Once your code passes the correctness test, do your best to optimize its performance. Your results from the MI and MSI runs will be averaged together. Go crazy!

4.1 Submission

Use the following command to prepare your code for submission, and upload the resulting `mt-matmul.zip` file to the Gradescope autograder.

```
eecs$ cd ${LAB5ROOT}/lab
eecs$ make zip-matmul
```

Note that code outside of `mt-matmul_opt.c` will be ignored.

- ! → *If you were not able to get the performance you desired on the Gradescope autograder, you may submit an **optional** written report, presenting 3 to 5 significant ideas you tried for improving performance along with some analysis for each idea.*

4.2 Matrix Multiply Tips

A number of strategies can be used to optimize your code for this problem. First, the problem size is for 32×32 matrices of `int` elements, with a total memory footprint of 12 KiB (the L1 data cache is only 4 KiB, 4-way set-associative). Common techniques that generally work well are loop unrolling, lifting loads out of inner loops and scheduling them earlier, blocking the code to utilize the full register file, transposing matrices to achieve unit-stride accesses to make full use of the L1 cache lines, and loop interchange.

You will also want to minimize sharing between cores; in particular, you will want to have each core responsible for writing its own pieces of the arrays (to avoid false sharing that causes lines to ping-pong between caches). Under the MI coherence protocol, it is also useful to avoid having both cores access the same portions of the input arrays at any given time, as there is no “S” state to accommodate shared lines.

5 Feedback Portion

5.1 Lab Group Feedback

Please complete this short survey regarding your lab group this semester by following the link: [Survey for lab group feedback](#).

6 Acknowledgments

This lab was made possible through the hard work of Andrew Waterman and Henry Cook (among others) in developing the Rocket processor, memory system, cache coherence protocols, and multi-threading software environment. This lab was originally developed for CS152 at UC Berkeley by Christopher Celio.

References

- [1] A. Waterman and K. Asanović, Eds., *The RISC-V instruction set manual, volume I: User-level ISA*, Version 20191213, RISC-V Foundation, Dec. 2019. [Online]. Available: <https://riscv.org/specifications/>.
- [2] A. Waterman and K. Asanović, Eds., *The RISC-V instruction set manual, volume II: Privileged architecture*, Version 20190608-Priv-MSU-Ratified, RISC-V Foundation, Jun. 2019. [Online]. Available: <https://riscv.org/specifications/privileged-isa/>.