

Lecture #19: More Special Effects—Exceptions and OOP

- Test #2 in two weeks (14 April), in class.
- Autograder runs Sunday night "sometime."

Exceptions and Continuations

- Exception-handling in programming languages is a very limited form of continuation.
- Execution continues after a function call that is still active when exception raised.
- Java provides mechanism to return a value with the exception, but this adds no new complexity.

Approach I: Do Nothing

- Some say keep it simple; don't bother with exceptions.
- Use return code convention:

Example: C library functions often return either 0 for OK or non-zero for various degrees of badness.

- Problems:

Approach I: Do Nothing

- Some say keep it simple; don't bother with exceptions.
- Use return code convention:
 - Example: C library functions often return either 0 for OK or non-zero for various degrees of badness.
- Problems:
 - Forgetting to check.
 - Code clutter.
 - Clumsiness: makes value-returning functions less useful.
 - Slight cost in always checking return codes.

Approach II: Non-Standard Return

- First idea is to modify calls so that they look like this:

```
    call _f
    jmp  OK
    code to handle exception
OK:
    code for normal return
```

- To throw exception:
 - Put type of exception in some standard register or memory location.
 - Return to instruction *after* normal return.
- Awkward for the ia32 (above). Easier on machines that allow returning to a register+constant offset address [why?].
- Exception-handling code decides whether it can handle the exception, and does another exception return if not.
- Problem: Requires small distributed overhead for every function call.

Approach III: Stack manipulation

- C does not have an exception mechanism built into its syntax, but uses library routines:

```
jmp_buf catch_point;
```

```
void Caller () {  
    if (setjmp (catch_point) == 0) {  
        normal case, which eventually  
        gets down to Callee  
    } else {  
        handle exception  
    }  
}
```

catch_point:

Caller's
FP, SP,
addr of
setjmp call
& others

```
void Callee () {  
    ...  
    // Throw exception:  
    longjmp (catch_point, 42);  
    ...  
}
```

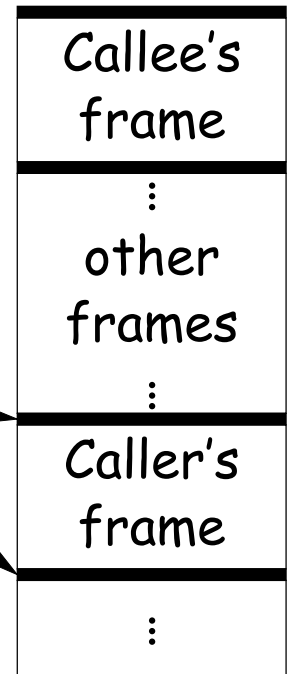

Approach III: Stack manipulation

- *C* does not have an exception mechanism built into its syntax, but uses library routines:

```
jmp_buf catch_point;
```

```
void Caller () {  
    if (setjmp (catch_point) == 0) {  
        normal case, which eventually  
        gets down to Callee  
    } else {  
        handle exception  
    }  
}
```

```
void Callee () {  
    ...  
    // Throw exception:  
    longjmp (catch_point, 42);  
    ...  
}
```

catch_point:

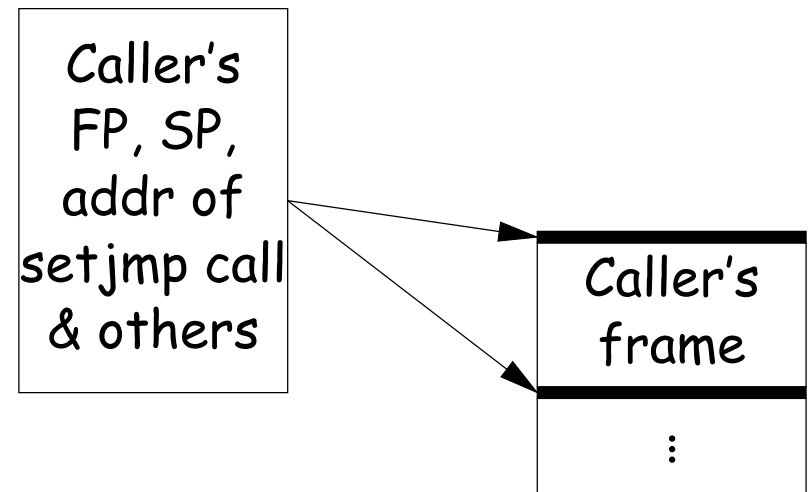

When longjmp called, restore stack as indicated by catch_point and return to the end of the setjmp call.

Approach III: Discussion

- On exception, call to `setjmp` appears to return twice, with two different values.
- Does not require help from compiler,
- But implementation is architecture-specific.
- Overhead imposed on every `setjmp` call.
- If used to implement `try` and `catch`, therefore, would impose cost on every `try`.
- Subtle problems involving variables that are stored in registers:
 - The `jmp_buf` typically has to store such registers, but
 - That means the value of some local variables may revert unpredictably upon a `longjmp`.

Approach IV: PC tables

- Sun's Java implementation uses a different approach.
- Compiler generates a table mapping instruction addresses (program counter (PC) values) to exception handlers for each function.
- If needed, compiler also leaves behind information necessary to return from a function ("unwind the stack") when exception thrown.
- To throw exception E:
 - while (current PC doesn't map to handler for E)
unwind stack to last caller
- Under this approach, a try-catch incurs no cost unless there is an exception, but
- Throwing and handling the exception more expensive than other approaches, and
- Tables add space.

New Topic: Dynamic Method Selection and OOP

- “Interesting” language feature introduced by Simula 67, Smalltalk, C++, Java: the *virtual function* (to use C++ terminology).
- Problem:
 - Arrange classes in a hierarchy of types.
 - Instance of subtype “is an” instance of its supertype(s).
 - In particular, inherits their methods, but can override them.
 - A *dynamic effect*: Cannot in general tell from program text what body of code executed by a given call.
- Implementation difficulty (as usual) depends on details of a language’s semantics.
- Some things still static:
 - Names of functions, numbers of arguments are (usually) known
 - Compiler can handle overloading by inventing new names for functions. E.g., G++ encodes a function $f(\text{int } x)$ in class Q as `_ZN1Q1fEi`, and $f(\text{int } x, \text{int } y)$ as `_ZN1Q1fEii`.

I. Fully Dynamic Approach

- Regular Python has a completely dynamic approach to the problem:

```
class A:
    x = 2; def f (self): return 42

a = A (); b = A ()
print a.x, a.f()    # Prints 2 42
a.x = lambda (self, z): self.w * z
a.f = 13; a.w = 5
print a.x(3), a.f, a.w    # Prints 15 13 5
print b.x(3), b.f, b.w    # Error
print A.x                # Prints 2
A.x = lambda (self): 19
A.f = 2
A.v = 1
c = A ()
print c.x (), c.f, c.v    # Prints 19, 2, 1
```

Characteristics of Dynamic Approach

- Each class instance is independent. Contents of class definition merely used until a new value is assigned to an attribute of the instance.
- New attributes can be added freely to instances or to class.
- In other variants of this approach, there are no classes at all, only instances, and we get new instances by cloning existing objects, and possibly then adding new attributes.

Implementing the Dynamic Approach

- Simple strategy: just put a dictionary in every instance, and in class.
- Create an instance by making fresh copy of class's dictionary.
- Check for value of attribute in object's dictionary, then in that of its class, superclass, etc.
- All checking at runtime.
- All objects (or pointers) carry around dynamic type.

Pros and Cons of Dynamic Approach

- Extremely flexible
- Conceptually simple
- Implementation easy
- Space overhead: every instance has pointers to all methods
- Time overhead: lookup on each call
- No static checking

II. Straight Single Inheritance, Dynamic Typing

- Each class has fixed set of methods and instance variables
- Methods have fixed definition in each class.
- Classes can inherit from single superclass.
- Otherwise, types of parameters, variables, etc., still dynamic
- Basically technique in Smalltalk, Objective C.

Implementing the Smalltalk-like Approach

- Instances need not carry around copies of function pointers.
- Instead, each *class* has a data structure mapping method names to functions, and instance-variable names to offsets from the start of the object.

```
class A:  
  def f (...): body1  
  def g (...): body2  
  x = 3  
class B(A):  
  def f (...): body3  
  def h (...): body4  
  y = 2  
  
a = A ()  
b = B ()
```

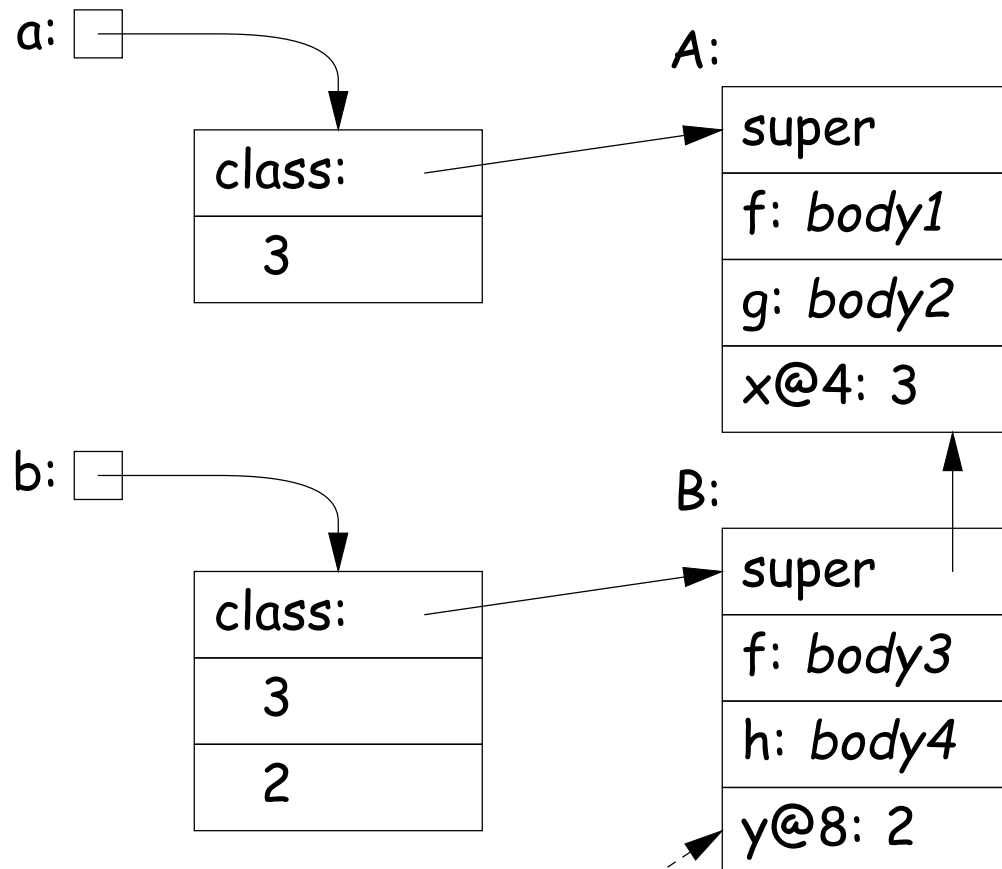

"y is stored at offset 8 from start of instance"

Pros and Cons of Smalltalk Approach

- Only need to store modifiable things—instance variables—in instances.
- Data structure can be a bit faster at accessing than fully dynamic method
- But still, not much static checking possible, and
- Some lookup of method names required.

Single Inheritance with Static Types

- Consider Java without interfaces. Type can inherit from at most one immediate superclass.
- For an access, $x.w$, insist that compiler knows a supertype of x 's dynamic type that defines w .
- Insist that all possible overridings of a method have compatible parameter lists and return values.
- Use a technique similar to previous one, but put entries for all methods (whether or not overridden) in each class data structure.
- Such class data structures are called "virtual tables" or "vtables" in C++ parlance.

Implementation of Simple Static Single Inheritance

```
class A {  
    void f () { body1 }  
    void g () { body2 }  
    int x = 3  
}
```

```
class B extends A {  
    void f () { body3 }  
    void h () { body4 }  
    int y = 2  
}
```

```
-----  
a = new A ()  
b = new B ()
```

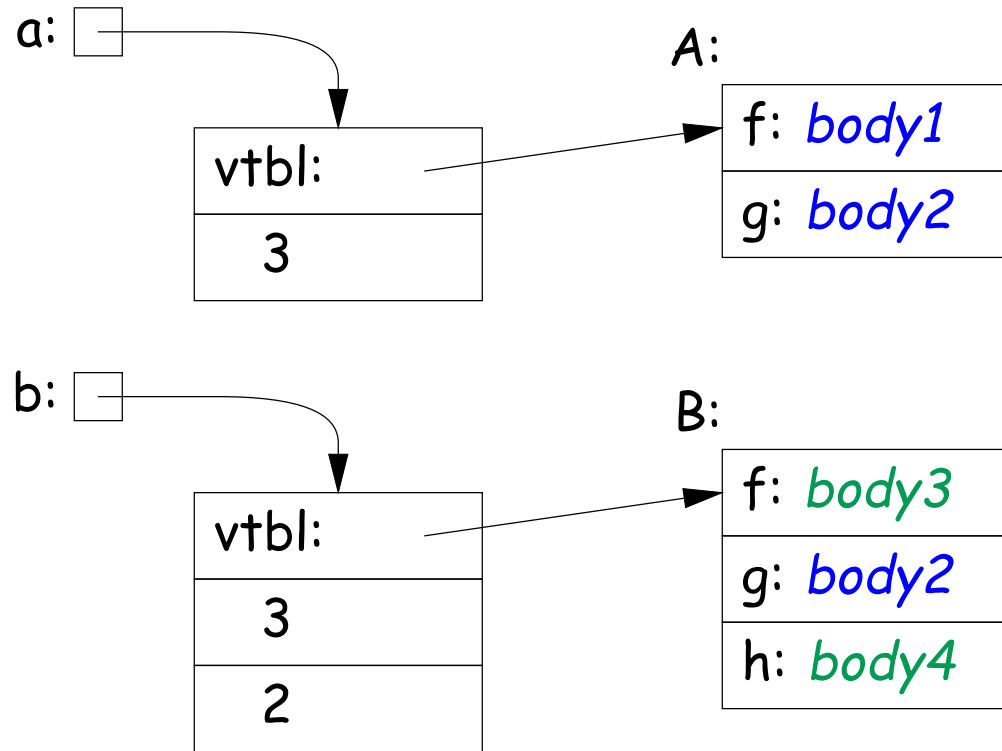

- No need to store offsets of x and y; compiler knows where they are.
- Also, compiler knows where to find 'f', 'g', 'h' virtual tables.
- **Important:** offsets of variables in instances and of method pointers in virtual tables are *known constants*, the *same for all subtypes*.
- So compiler knows how to call methods of b even if static type is A!

Interfaces

- Java allows *interface inheritance* of any number of interface types (introduces no new bodies).
- This complicates life: consider

```
class A {
    int x;
    public f () { ... }
}

class B {
    int y;
    g () { ... }
    h () { ... }
    public f () { ... }
}

interface C {
    f ();
}

/*-----*/
class A2 extends A
    implements C
{...}

class B2 extends B
    implements C
{ ... }

/*-----*/
void f (C y) { y.f () } // How can this work?
```

- We can compile A and B without knowledge of C, A2, B2.
- How can we make the virtual table of A2 and B2 compatible with each other so that f is at same known offset regardless of whether dynamic type of C is A2 or B2? (Above isn't hardest example!)

Interface Implementation I: Brute Force

- One approach is to have the system assign a different offset *globally* to each different function signature

(Functions $f(\text{int } x)$ and $f()$ have different function signatures)

- So in previous example, the virtual tables can be:

A:	B:	C:
0: unused	0: ptr to B.g	0: unused
4: unused	4: ptr to B.h	4: unused
8: ptr to A.f	8: ptr to B.f	8: unused
A2:	B2:	
0: unused	0: ptr to B.g	
4: unused	4: ptr to B.h	
8: ptr to A.f	8: ptr to B.f	

- No slowing of method calls.
- But, Total size of tables gets big (some optimization possible).
- And, must take into account all classes before laying out tables.

Complicates dynamic linking.

Interface Implementation II: Make Interface Values Different

- Another approach is to represent values of static type C (an interface type) differently.
- Converting value $x2$ of type $B2$ to C then causes C to point to a two-word quantity:
 - Pointer to $x2$
 - Pointer to a cut-down virtual table containing just the f entry from $B2$ (at offset 0).
- Means that converting to interface requires work and allocates storage.

Interface Implementation II, Illustrated

```
class A {  
    void f () { body1 }  
    void g () { body2 }  
    void h () { body3 }  
    int x = 3;  
}  
  
interface C { void g (); }  
  
class B extends A  
    implements C { }  
  
B b = new B ();  
C c = b;  
    // Create "interface object"  
c.g ();  
    // Get g from c.vtbl, ...  
    // ...and use c.obj as 'this'.
```

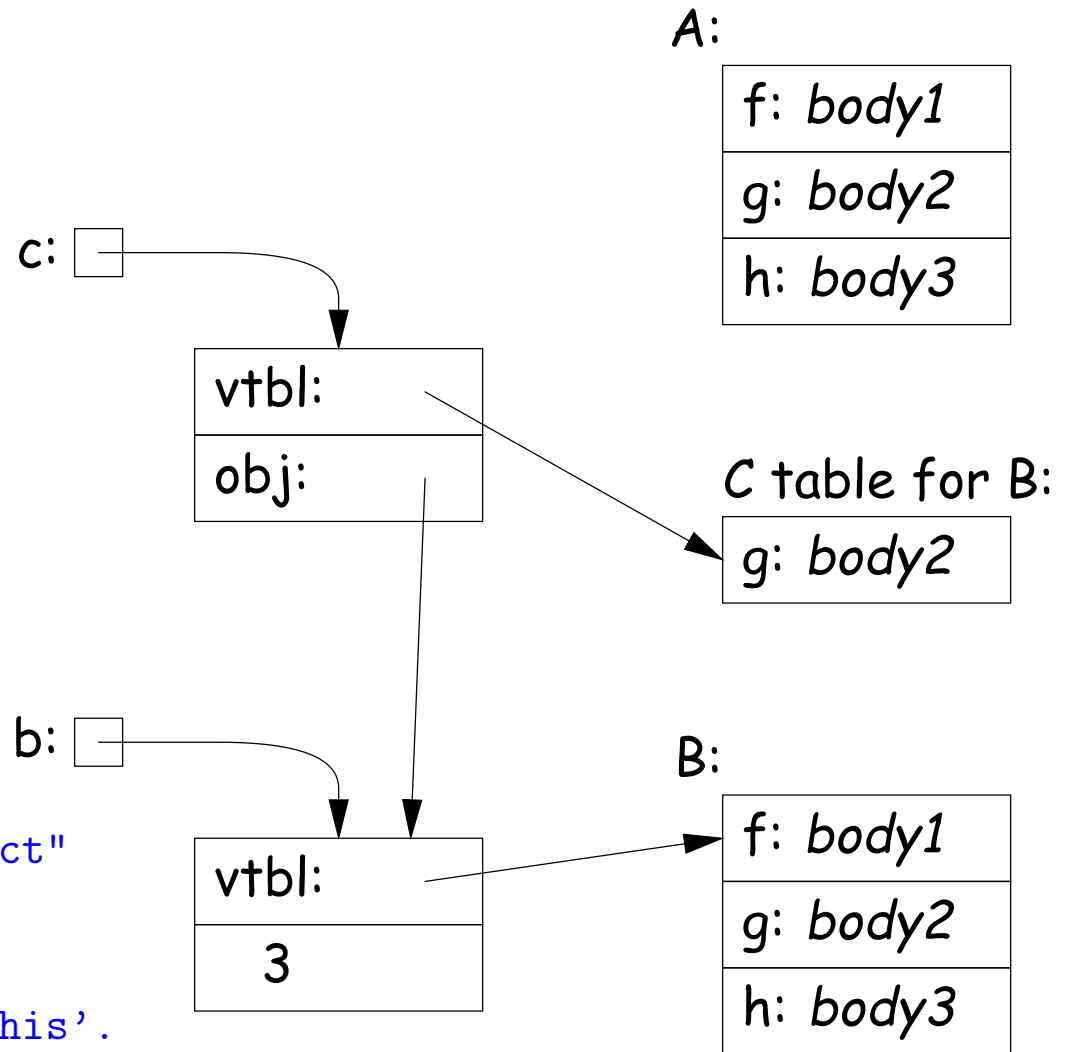

Improving Interface Implementation II

- How can we avoid doing allocation to create value of interface type *C*?
- One method: extend the virtual table of all types to include an *interface vector*.
- Each entry in this vector identifies an interface the type implements, plus the table (e.g. "C table for B" in last slide).
- To implement '*C c = b*' from last slide, just copy pointer *b*, as for the usual cases when assigning to a variable whose type is a super-type of the value assigned.
- To implement '*c.g()*' from last slide, find the "C table" in the interface vector for object pointed to be *c* and fetch the entry for *g*. Just call as usual.
- Question for the reader: How best to design the interface vector?
 - Want fetching of *c.g* to be fast,
 - So best to avoid having to actually perform a search at execution time. How?

Full Multiple Interitance

- Java allows multiple inheritance only via interfaces.
- Important point: *interfaces don't have instance variables*.
- Instance variables basically mess everything up for multiple inheritance, assuming we want to keep constant offsets to instance variables.

```
class A {  
    int x = 19;  
    void f () { ... x ... h() ... }  
    void h () {... }  
}
```

```
class B {  
    int y = 42;  
    void g () { ... y ... h() ... }  
    void h () {... }  
}
```

```
class D extends A, B {  
    // Where do x and y go?  
    void h () {... }  
}
```

- If `aD` is a `D`, then `aD.f` expects that 'this' points to an `A`, `aD.g` expects that it points to a `B`, but `aD.h` expects it to point to a `D`.
- How can these all be true??

Implementing Full Multiple Inheritance I

- Idea is to extend the contents of the virtual table with an offset for each method.
- Offset tells how to adjust the 'this' pointer before calling.
- For the classes from the last slide:

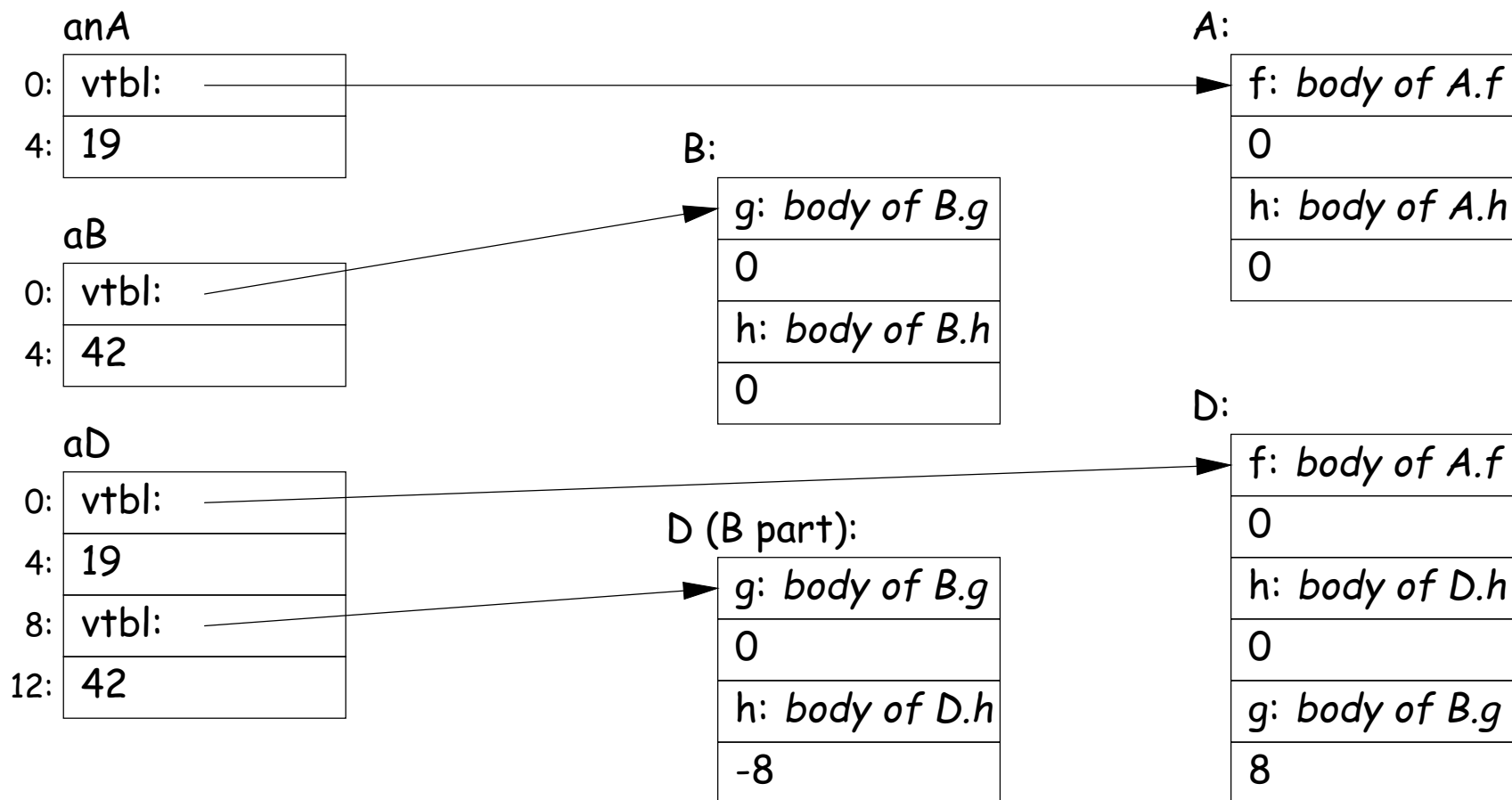

Implementing Full Multiple Inheritance I (contd.)

- To call `aD.g`,
 - Fetch function address of `g` from `D` table.
 - Call it, but first add 8 to pointer value of `aD` so as to get a pointer to the "B part" of `aD`.
- When `aD.g` eventually calls `h` (actually `this.h`),
 - 'this' refers to the "B part" of `aD`.
 - Its virtual table is "D (B part)" in the preceding slide.
 - Fetching `h` from that table gives us `D.h`, ...
 - ...which we call, after first adding the -8 offset from the table to "this."
 - Thus, we end up calling `D.h` with a "this" value that points to `aD`, as it expects.

Implementing Full Multiple Inheritance II

- First implementation slows things down in all cases to accommodate unusual case.
- Would be better if only the methods inherited from B (for example) needed extra work.
- Alternative design: use stubs to adjust the 'this' pointer.
- Define $B.g_1$ to add 8 to the 'this' pointer by 8 and then call $B.g$; and $D.h_1$ to subtract 8 and then call $D.h$:

