

Lecture 5: Parsing

Administrivia

- Project #1 specification and skeleton released. Due in one month. Start today! Write test cases!
- Homework #3 posted.
- If you do not have a group, please send us mail. We will form groups semi-randomly. You may not submit a project without a group of at least two

A Glance at the Map

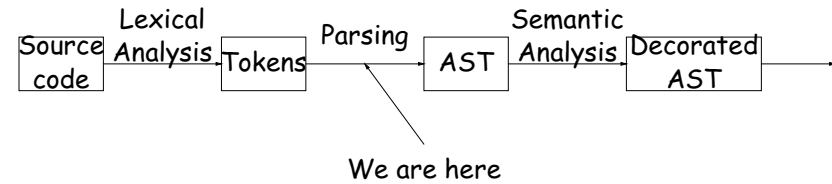

Review: BNF

- BNF is another pattern-matching language;
- Alphabet typically set of *tokens*, such as from lexical analysis, referred to as *terminal symbols* or *terminals*.
- Matching rules have form:

$$X : \alpha_1\alpha_2\cdots\alpha_n,$$

where X is from a set of *nonterminal symbols* (or *nonterminals* or *meta-variables*), $n \geq 0$, and each α_i is a terminal or nonterminal symbol.

- For emphasis, may write $X : \epsilon$ when $n = 0$.
- Read $X : \alpha_1\alpha_2\cdots\alpha_n$, as

"An X may be formed from the concatenation of an $\alpha_1, \alpha_2, \dots, \alpha_n$."

- Designate one nonterminal as the *start symbol*.
- Set of all matching rules is a *context-free grammar*.

Review: Derivations

- String (of terminals) T is in the language described by grammar G , ($T \in L(G)$) if there is a *derivation of T* from the start symbol of G .
- Derivation of $T = \tau_1\cdots\tau_k$ from nonterminal A is sequence of *sentential forms*:

$$A \Rightarrow \alpha_{11}\alpha_{12}\dots \Rightarrow \alpha_{21}\alpha_{22}\dots \Rightarrow \cdots \Rightarrow \tau_1\cdots\tau_k$$

where each α_{ij} is a terminal or nonterminal symbol.

- We say that

$$\alpha_1\cdots\alpha_{m-1}B\alpha_{m+1}\cdots\alpha_n \Rightarrow \alpha_1\cdots\alpha_{m-1}\beta_1\cdots\beta_p\alpha_{m+1}\cdots\alpha_n$$

if $B : \beta_1\cdots\beta_p$ is a production. ($1 \leq m \leq n$).

- If Φ and Φ' are sentential forms, then $\Phi_1 \xRightarrow{*} \Phi_2$ means that 0 or more \Rightarrow steps turns Φ_1 into Φ_2 . $\Phi_1 \xRightarrow{+} \Phi_2$ means 1 or more \Rightarrow steps does it.
- So if S is start symbol of G , then $T \in L(G)$ iff $S \xRightarrow{+} T$.

Example of Derivation

1. $e : s \text{ ID}$
2. $e : s \text{ ' (' e ') '}$
3. $e : e \text{ ' / ' e}$
4. $s :$
5. $s : \text{'+'}$
6. $s : \text{'-'}$

Alternative Notation

- $$e : s \text{ ID}$$
- $$| s \text{ ' (' e ') '}$$
- $$| e \text{ ' / ' e}$$
- $$s : \epsilon \text{ | ' + ' | ' - '}$$

Problem: Derive - ID / (ID / ID)

$$e \xrightarrow{3} e / e \xrightarrow{1} s \text{ ID} / e \xrightarrow{6} - \text{ID} / e \xrightarrow{2} - \text{ID} / s (e)$$

$$\xrightarrow{4} - \text{ID} / (e) \xrightarrow{3} - \text{ID} / (e / e) \xrightarrow{1} - \text{ID} / (s \text{ ID} / e)$$

$$\xrightarrow{4} - \text{ID} / (\text{ID} / e) \xrightarrow{1} - \text{ID} / (\text{ID} / s \text{ ID})$$

$$\xrightarrow{4} - \text{ID} / (\text{ID} / \text{ID})$$

Types of Derivation

- **Context free** means can replace nonterminals in any order (i.e., regardless of context) to get same result (as long as you use same productions).
- So, if we use a particular rule for selecting nonterminal to "produce" from, can characterize derivation by just listing productions.
- Previous example was **leftmost derivation**: always choose leftmost nonterminals. Completely characterized by list of productions: 3, 1, 6, 2, 4, 3, 1, 4, 1, 4.

Derivations and Parse Trees

- A leftmost derivation also completely characterized by parse tree:

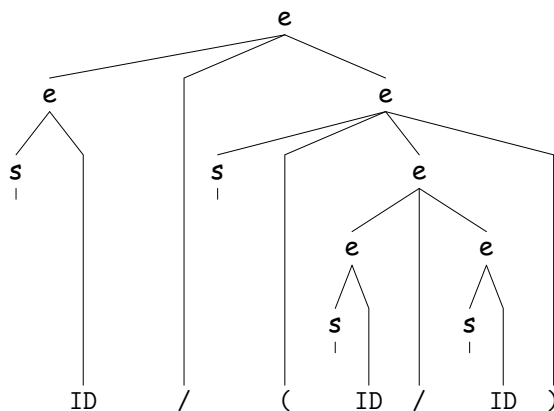

- What is the rightmost derivation for this?

$$e \xrightarrow{3} e / e \xrightarrow{2} e / s (e) \xrightarrow{3} e / s (e / e)$$

$$\xrightarrow{1} e / s (e / s \text{ ID}) \xrightarrow{4} e / s (e / \text{ID})$$

$$\xrightarrow{1} e / s (s \text{ ID} / \text{ID}) \xrightarrow{4} e / s (\text{ID} / \text{ID})$$

$$\xrightarrow{4} e / (\text{ID} / \text{ID}) \xrightarrow{1} s \text{ ID} / (\text{ID} / \text{ID}) \xrightarrow{6} - \text{ID} / (\text{ID} / \text{ID})$$

Ambiguity

- Only one derivation for previous example.
- What about 'ID / ID / ID'?
- Claim there are two parse trees, corresponding to two leftmost derivations. What are they?

- If there exists even one string like ID / ID / ID in $L(G)$, we say G is ambiguous (even if other strings only have one parse tree).

Ambiguity

- Only one derivation for previous example.
- What about 'ID / ID / ID'?
- Claim there are two parse trees, corresponding to two derivations. What are they?

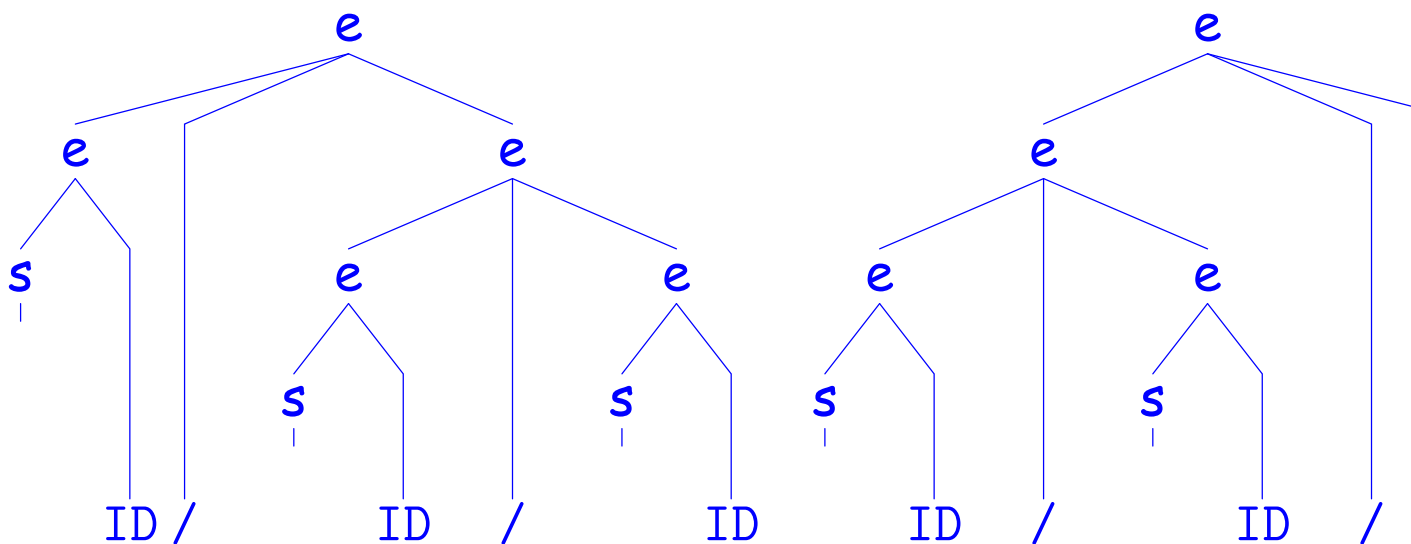

- If there exists even one string like ID / ID / ID in $L(G)$, G is ambiguous (even if other strings only have one parse tree)

Review: Syntax-Directed Translation

- Want the structure of sentences, not just whether they are in the language, because this drives translation.
- Associate translation rules to each production, just as Flex associated actions with matching patterns.
- Bison notation:

```
e : e '/' e          { $$ = doDivide($1, $3); }
```

provides way to refer to and set *semantic values* on each node of a parse tree.
- Compute these semantic values from leaves up the parse tree.
- Same as the order of a *rightmost derivation in reverse* (a.k.a a *canonical derivation*).
- Alternatively, just perform arbitrary actions in the same order.

Example: Conditional statement

Problem: *if-else* or *if-elif-else* statements in Python (*else* optional). Assume that only (indented) suites may be used for then and else clauses, that nonterminal *stmt* defines an individual statement (one per line), and that nonterminal *expr* defines an expression. Lexer supplies *INDENTS* and *DEDENTS*. A *cond* is a kind of *stmt*.

```
expr : ...
stmt : ... | cond | ...
cond : "if" expr ':' suite elifs else
suite: INDENT stmts DEDENT
stmts: stmt | stmts stmt
elifs: ε | "elif" expr ':' suite elifs
else : ε | "else" expr ':' suite
```

Example: Conditional statement in Java

Problem: *if-else* in Java. Assume that nonterminal *stmt* defines an individual statement (including a block in `{}`).

```
expr : ...
stmt : ... | cond | ...
cond : "if" '(' expr ')' stmt else
else : ε | "else" stmt
```

But this doesn't quite work: recognizes correct statements and rejects incorrect ones, but is ambiguous. E.g.,

```
if (foo) if (bar) walk(); else chewGum();
```

Do we chew gum if foo is false? That is, is this equivalent to

```
if (foo) { if (bar) walk(); } else chewGum();
/*or*/ if (foo) { if (bar) walk(); else chewGum(); } ?
```

Example resolved: Conditional statement in Java

The rule is supposed to be "each 'else' attaches to the nearest open 'if' on the left," which is captured by:

```
expr : ...
stmt : ... | cond | ...
stmt_closed : ... | cond_closed | ...
cond_closed : "if" '(' expr ')' stmt_closed "else" stmt_closed
cond : "if" '(' expr ')' stmt
      | "if" '(' expr ')' stmt_closed "else" stmt
```

This does not allow us to interpret

```
if (foo) if (bar) walk(); else chewGum();
```

as

```
if (foo) { if (bar) walk(); } else chewGum();
```

But it's not exactly clear, is it?

Puzzle: NFA to BNF

Problem: What BNF grammar accepts the same string as this NFA?

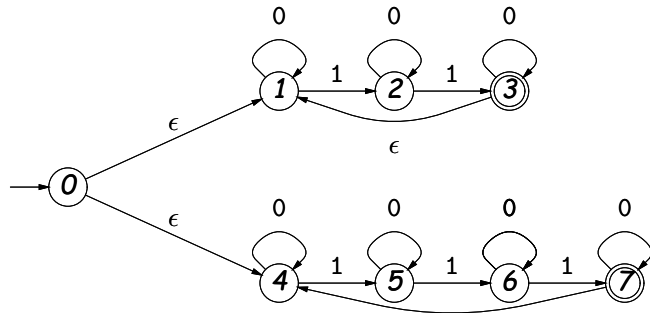

A general answer, with one nonterminal per state:

S0: S1 S4	S4: '1' S5 '0' S4
S1: '1' S2 '0' S1	S5: '1' S6 '0' S5
S2: '1' S3 '0' S2	S6: '1' S7 '0' S6
S3: S1 '0' S3 ϵ	S7: S4 '0' S7 ϵ

Interpret nonterminal S_k as "the set of strings that will get me from S_k in the NFA to a final state in the NFA."