

Q1. Surrealist Pacman

In the game of Surrealist Pacman, Pacman \ominus plays against a moving wall \boxplus . On Pacman's turn, Pacman must move in one of the four cardinal directions, and must move into an unoccupied square. On the wall's turn, the wall must move in one of the four cardinal directions, and must move into an unoccupied square. The wall cannot move into a dot-containing square. Staying still is not allowed by either player. Pacman's score is always equal to the number of dots he has eaten.

The first game begins in the configuration shown below. Pacman moves first.

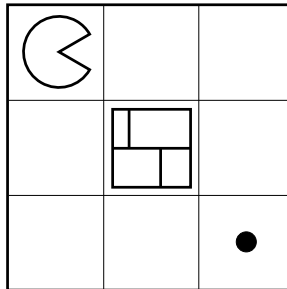

- (a) Draw a game tree with one move for each player. Nodes in the tree represent game states (location of all agents and walls). Edges in the tree connect successor states to their parent states. Draw only the legal moves.

- (b) According to the depth-limited game tree you drew above what is the value of the game? Use Pacman's score as your evaluation function.

- (c) If we were to consider a game tree with ten moves for each player (rather than just one), what would be the value of the game as computed by minimax?

A second game is played on a more complicated board. A partial game tree is drawn, and leaf nodes have been scored using an (unknown) evaluation function e .

- (d) In the dashed boxes, fill in the values of all internal nodes using the minimax algorithm.
- (e) Cross off any nodes that are not evaluated when using alpha-beta pruning (assuming the standard left-to-right traversal of the tree).

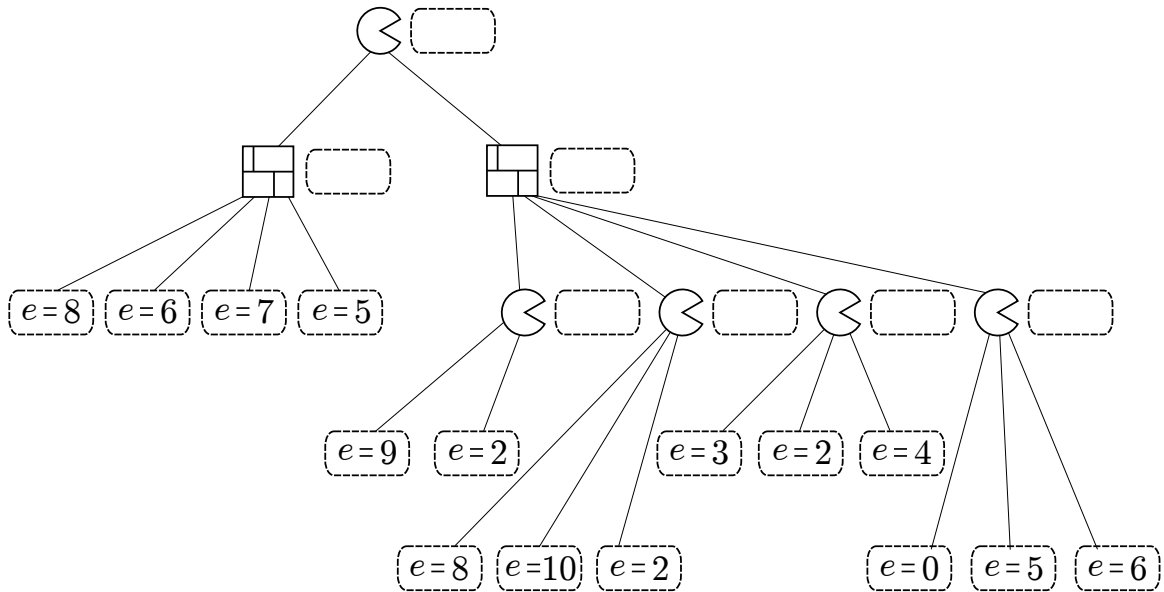

Suppose that this evaluation function has a special property: it is known to give the correct minimax value of any internal node to within 2, and the correct minimax values of the leaf nodes exactly. That is, if v is the true minimax value of a particular node, and e is the value of the evaluation function applied to that node, $e - 2 \leq v \leq e + 2$, and $v = e$ if the node is a dashed box in the tree below.

Using this special property, you can modify the alpha-beta pruning algorithm to prune more nodes.

- (f) Standard alpha-beta pseudocode is given below (only the max-value recursion). Fill in the boxes on the right to replace the corresponding boxes on the left so that the pseudocode prunes as many nodes as possible, taking account of this special property of the evaluation function.

```

function MAX-VALUE(node,  $\alpha$ ,  $\beta$ )
   $e \leftarrow$  EVALUATIONFUNCTION(node)
  if node is leaf then
    return  $e$ 
  end if
   (1)
   $v \leftarrow -\infty$ 
  for child  $\leftarrow$  CHILDREN(node) do
     (2)
    if  $v \geq \beta$  then
      return  $v$ 
    end if
     $\alpha \leftarrow$  MAX( $\alpha$ ,  $v$ )
  end for
  return  $v$ 
end function

```

Fill in these boxes:

(1)

(2)

The same game tree is shown below, with the evaluation function applied to *internal* as well as leaf nodes.

- (g) In the game tree below cross off any nodes that can be pruned assuming the special property holds true. If not sure you correctly formalized into pseudo-code your intuition on how to exploit the special property for improved pruning, make sure to annotate your pruned nodes with a brief explanation of why each of them was pruned.

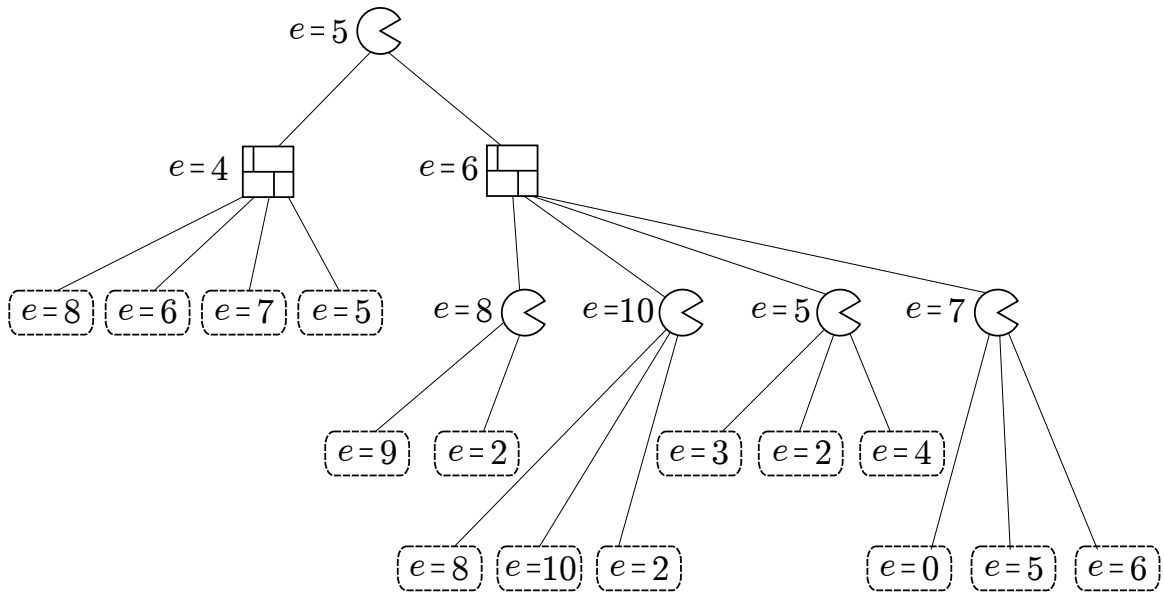

Q2. Bounded Expectimax

- (a) **Expectimax.** Consider the game tree below, where the terminal values are the *payoffs* of the game. Fill in the expectimax values, assuming that player 1 is maximizing expected payoff and player 2 plays uniformly at random (i.e., each action available has equal probability).

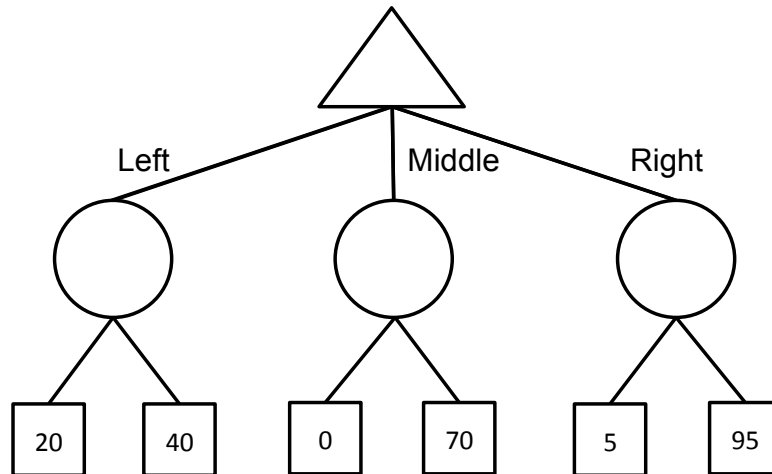

- (b) Again, assume that Player 1 follows an expectimax strategy (i.e., maximizes expected payoff) and Player 2 plays uniformly at random (i.e., each action available has equal probability).
- What is Player 1's expected payoff if she takes the expectimax optimal action?
 - Multiple outcomes are possible from Player 1's expectimax play. What is the worst possible payoff she could see from that action?
- (c) Even if the average outcome is good, Player 1 doesn't like that very bad outcomes are possible. Therefore, rather than purely maximizing expected payoff using expectimax, Player 1 chooses to perform a modified search. In particular, she only considers actions whose worst-case outcome is 10 or better.
- Which action does Player 1 choose for this tree?
 - What is the expected payoff for that action?
 - What is the worst payoff possible for that action?

(d) Now let's consider a more general case. Player 1 has the following preferences:

- Player 1 prefers any lottery with worst-case outcome of 10 or higher over any lottery with worst-case outcome lower than 10.
- Among two lotteries with worst-case outcome of 10 or higher, Player 1 chooses the one with the highest expected payoff.
- Among two lotteries with worst-case outcome lower than 10, Player 1 chooses the one with the highest worst-case outcome (breaking ties by highest expected payoff).

Player 2 still always plays uniformly at random.

To compute the appropriate values of tree nodes, Player 1 must consider both expectations and worst-case values at each node. For each node in the game tree below, fill in a pair of numbers (e, w) . Here e is the expected value under Player 1's preferences and w is the value of the worst-case outcome under those preferences, assuming that Player 1 and Player 2 play according to the criteria described above.

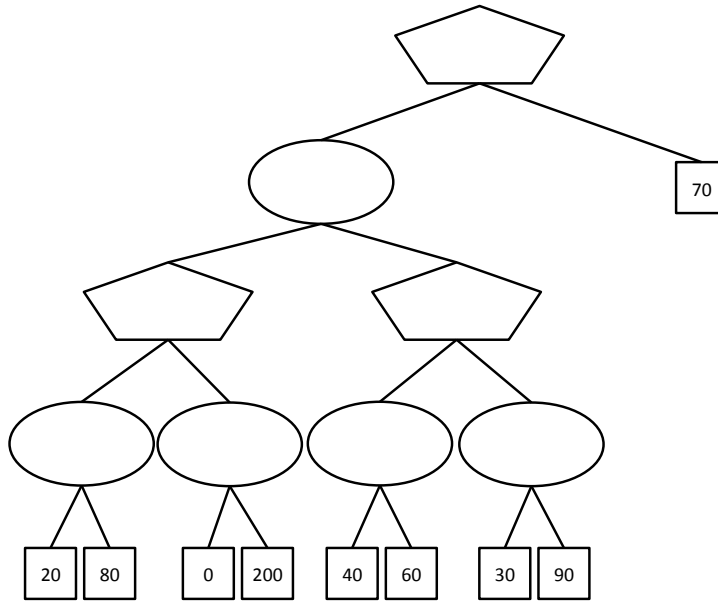

(e) Now let's consider the general case, where the lower bound used by Player 1 is a number L not necessarily equal to 10, and not referring to the particular tree above. Player 2 still plays uniformly at random.

(i) Suppose a Player 1 node has two children: the first child passes up values (e_1, w_1) , and the second child passes up values (e_2, w_2) . What values (e, w) will be passed up by a Player 1 node if

1. $w_1 < w_2 < L$
2. $w_1 < L < w_2$
3. $L < w_1 < w_2$

(ii) Now consider a Player 2 node with two children: the first child passes up values (e_1, w_1) and the second child passes up values (e_2, w_2) . What values (e, w) will be passed up by a Player 2 node if

1. $w_1 < w_2 < L$

2. $w_1 < L < w_2$

3. $L < w_1 < w_2$

Q3. Expectimax

Your little brother Timmy has a birthday and he was promised a toy. However, Timmy has been misbehaving lately and Dad thinks he deserves the least expensive present. Timmy, of course, wants the most expensive toy. Dad will pick the city from which to buy the toy, Timmy will pick the store and you get to pick the toy itself. You don't want to take sides so you decide to pick a toy at random. All prices (including X and Y) are assumed to be nonnegative.

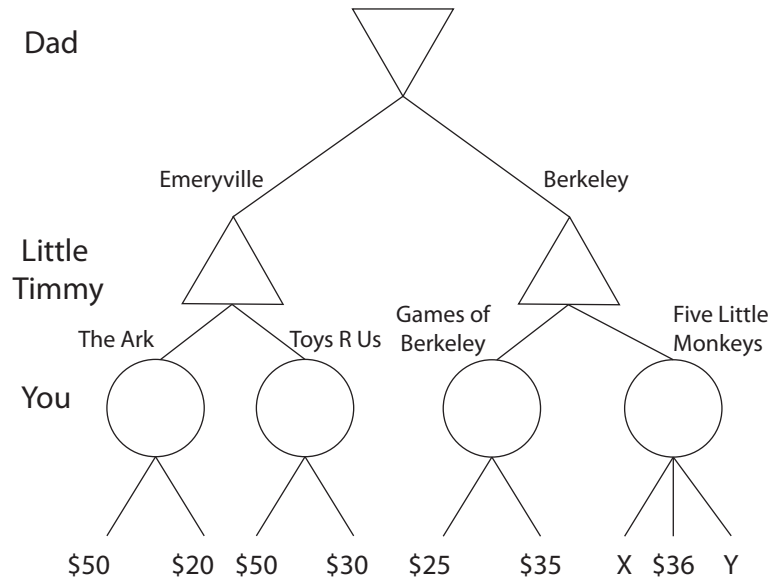

- (a) Fill in the values of all the nodes that don't depend on X or Y.
- (b) What values of X will make Dad pick Emeryville regardless of the price of Y?

- (c) We know that Y is at most \$30. What values of X will result in a toy from Games of Berkeley regardless of the exact price of Y?

- (d) Normally, alpha-beta pruning is not used with expectimax. However, with some additional information, it is possible to do something similar. Which **one** of the following conditions on a problem are required to perform pruning with expectimax?
 1. The children of the expectation node are leaves.

2. All values are positive.
3. The children of the expectation node have specified ranges.
4. The child to prune is last.