

Logic Gates

Fill in the following truth tables:

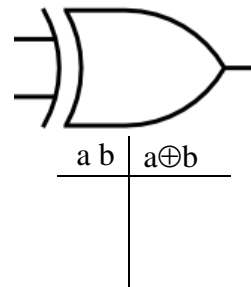
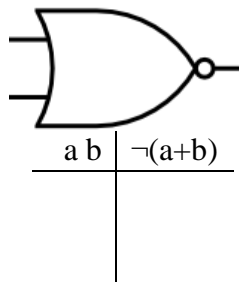
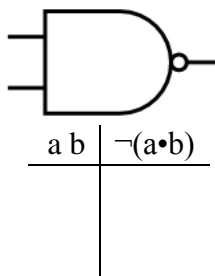
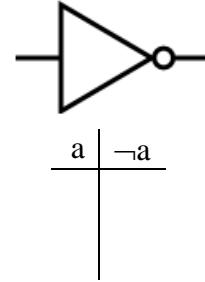
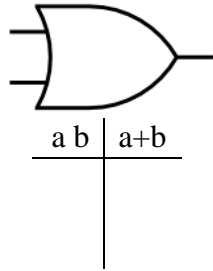
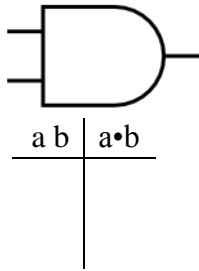

Create an inverter (NOT gate) using only NAND gates (Hint: look at the truth tables for each).

State Elements

One of the basic building blocks of SDS. State elements provide a means of storing values, and controlling the flow of information in the circuit. The most basic state element (we're concerned with) is a DQ Flip-Flop:

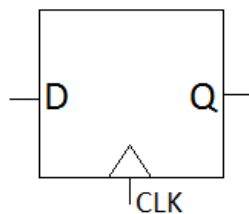

D is a single bit input, Q is a single bit output. On the **rising edge** of the clock, the value from D is copied to Q, after a small delay (known as the Clk-to-Q delay). At all other times, Q presents the value last copied and ignores D.

An n-bit register is just n DQ Flip-Flops aligned in parallel, tied to the same clock.

Timing Diagrams: Fill out the timing diagrams for the circuits below.

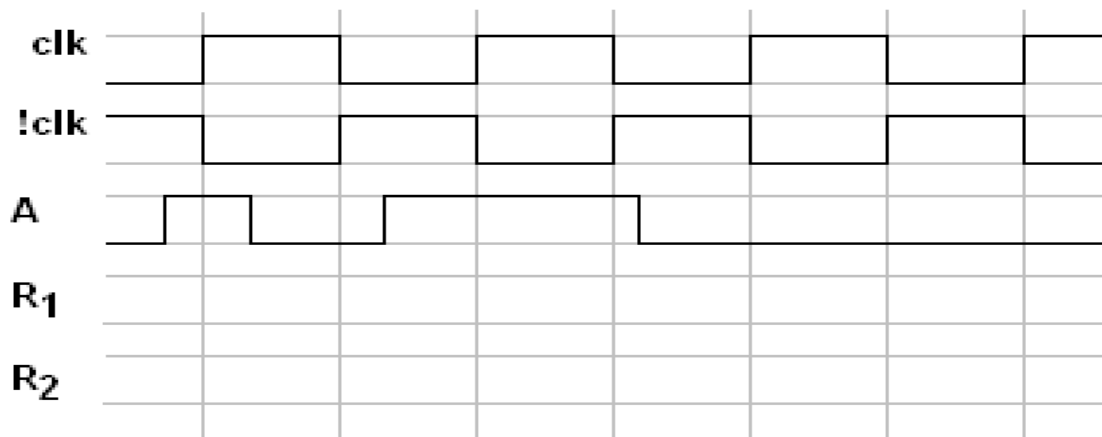
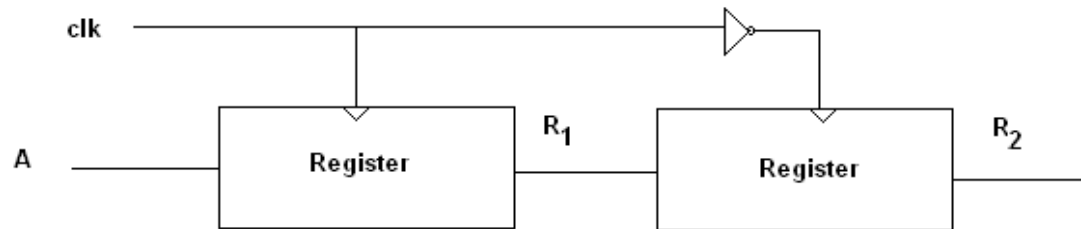
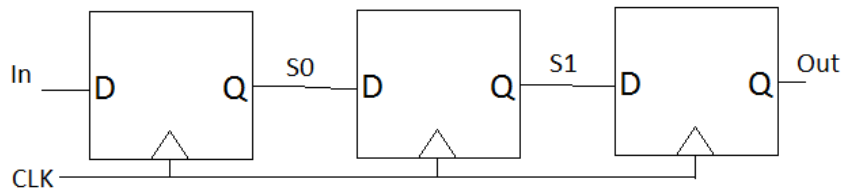

Finite State Machines

FSMs can be an incredibly useful computational tool. They have a straightforward implementation in hardware:

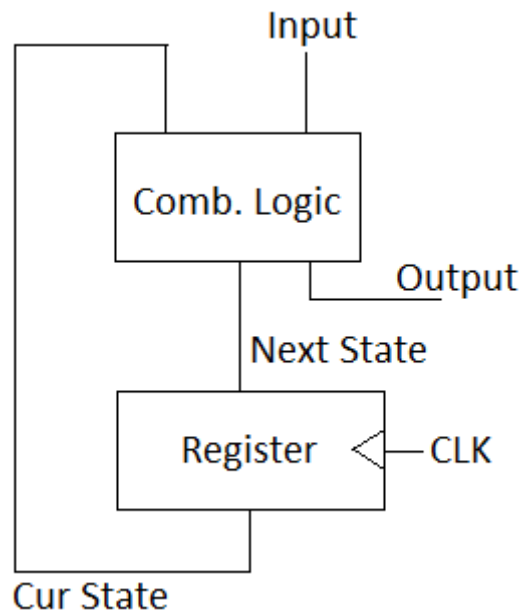

The register holds the current state (encoded as a particular combination of bits), and the combinational logic block maps from {current state, input} to {next state, output}.

Exercises

Draw a transition diagram for an FSM that can take in an input sequence one bit at a time, and after each input is received, output whether the number of 1s is divisible by 3. Write out the truth table that the combinational logic block must implement.