

EE105 Lab Experiments

Experiment 10: Differential Amplifiers

1 Objective

Differential amplifiers are designed to amplify the difference between two signals. Differential amplifiers are thereby able to reduce noise that is common to both inputs, only amplifying the differential signal that we're interested in. We can quantify the differential-mode versus common-mode gain in a quantity called the common-mode rejection ratio (CMRR). Differential amplifiers also lend themselves to use in feedback, though we will not explore that usage in this lab. A typical differential amplifier with a single-ended output that you are familiar with is the op-amp.

2 Materials

For this lab, assume all NPN transistors are identical 2N3904 BJTs and all PNP transistors are identical 2N3906 BJTs.

Component	Quantity
LM741 op-amp	1
2N3904 NPN BJT	4
2N3906 PNP BJT	2
1 k Ω resistor	2
5.1 k Ω resistor	2
10 k Ω resistor	2
0.1 μ F capacitor	1

Table 1: Components used in this lab

Component	I_S (A)	V_A (V)
2N3904 NPN BJT	6.734×10^{-15}	74.03
2N3906 PNP BJT	1.41×10^{-15}	18.7

Table 2: Transistor properties

3 Procedure

3.1 Generating a differential signal

Before building a differential amplifier, we'd like to be able to generate a differential signal. This requires inverting an analog signal. One way we can do this is by using an op-amp in negative feedback, as shown in Figure 1.

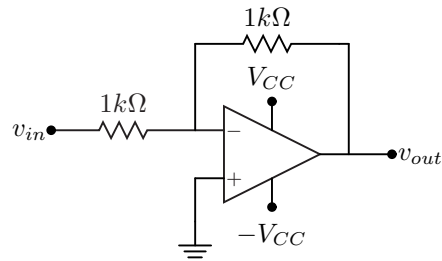

Figure 1: Inverting amplifier

1. Construct the circuit in Figure 1. Use the LM741 op-amp. The pin layout for the LM741 op-amp is in Figure 2. *Note: If your LM741 doesn't have a notch as shown in the figure, check for a small dot. This dot labels pin 1.*

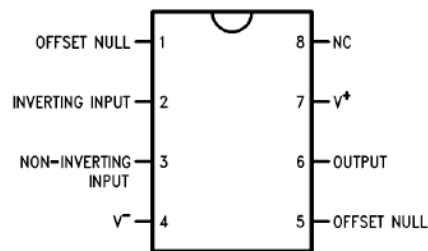

Figure 2: LM741 pin layout

2. Apply a 30 mV amplitude, 1 kHz sine wave to the input. Display the input and output on the oscilloscope. The output should be the inverse of the input.

3.2 Differential pair with resistive load

1. Construct the circuit in Figure 3 using 2N3904 transistors for the NPN BJTs. Use $R_1 = 10\text{ k}\Omega$, $R_2 = R_3 = 5.1\text{ k}\Omega$, and $V_{CC} = 9\text{ V}$. This is the same circuit you analyzed in the prelab.

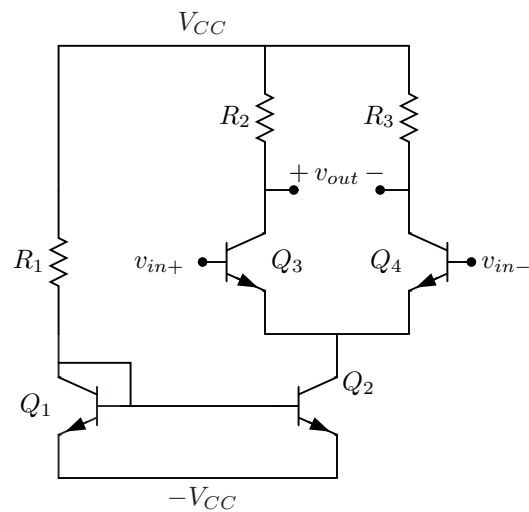

Figure 3: Differential pair with resistive load

2. Ground the inputs and measure I_{C1} , I_{C2} , I_{C3} , and $V_{out,DC}$ (the output DC bias). How do these values compare to what you'd expect from hand calculations?
3. Apply a 30 mV amplitude, 1 kHz sine wave to v_{in+} and ground v_{in-} . Use the oscilloscope to display the input waveform at v_{in+} and the output waveform at v_{out+} and sketch the result. If the input signal is noisy, use the averaging feature of the oscilloscope to get a more accurate result.
4. Use the oscilloscope to measure the peak-to-peak voltages of v_{in+} and v_{out+} .
5. Use the oscilloscope to display v_{out+} and v_{out-} . Do they appear as you'd expect?
6. Use the oscilloscope to display $v_{out+} - v_{out-}$. Measure the peak-to-peak voltage of the signal and calculate the differential gain of the circuit. Does this match the gain you calculated in the prelab?
7. Apply a 30 mV amplitude, 1 kHz sine wave to both v_{in+} and v_{in-} . Use the oscilloscope to display the output waveform at v_{out+} and v_{out-} . What do you see at the output? Why?
8. Use the inverting amplifier you built to apply a 20 mV amplitude, 1 kHz differential sine wave to the inputs (that means a 10 mV amplitude sine wave to v_{in+} and the inverted sine wave to v_{in-}). Measure the peak-to-peak voltage of the differential input and output with the oscilloscope. Does the gain match your prelab calculations? Does it match the gain you observed in step 3.2.6?

3.3 Differential pair with active load

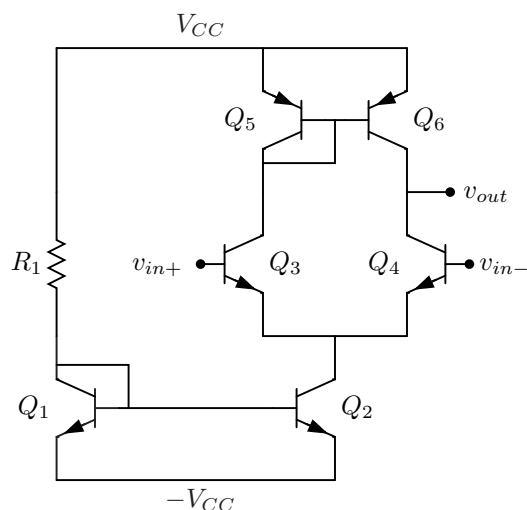

Figure 4: Differential pair with active load

1. Construct the circuit in Figure 4 using 2N3904 transistors for the NPN BJTs and 2N3906 transistors for the PNP BJTs. Use $R_1 = 10 \text{ k}\Omega$ and $V_{CC} = 9 \text{ V}$.
2. Apply a 30 mV amplitude, 1 kHz sine wave to v_{in+} and ground v_{in-} . Use the oscilloscope to display the output waveform at v_{out} and sketch the result. Why isn't the output sinusoidal?
3. We'd like to reduce R_{out} by loading the amplifier with a small resistor. Attach a load to the amplifier as shown in Figure 5. Use $C_L = 0.1 \text{ }\mu\text{F}$ and $R_L = 5 \text{ k}\Omega$.
4. Calculate the differential gain for the amplifier with the new load resistance.
5. Apply a 20 mV amplitude, 1 kHz sine wave to v_{in+} and ground v_{in-} . Use the oscilloscope to display v_{in+} and v_{out} . Sketch v_{out} . What is the measured differential gain of the circuit? How does this compare with your hand calculations? Does the gain match the differential gain you measured in step 3.2.6? Should it?

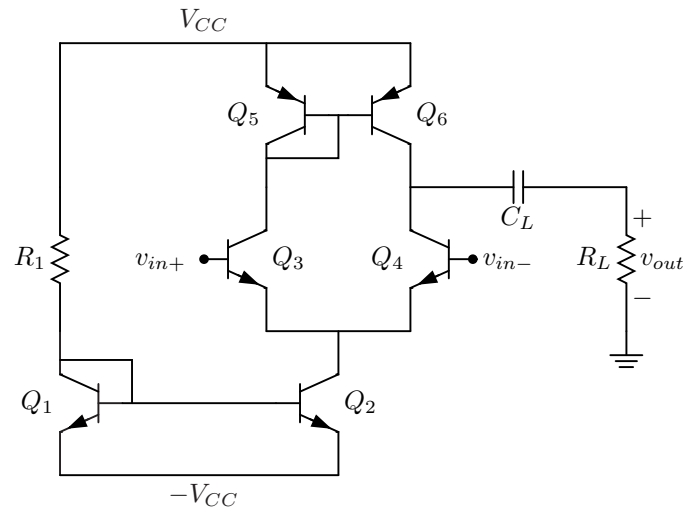

Figure 5: Differential pair with reduced output resistance

3.4 SPICE Analysis

1. Write a netlist for the circuit in Figure 3. Apply a differential input of amplitude 20 mV, frequency 1 kHz as you did in step 3.2.8. *Hint: Generate a 20 mV amplitude, 1 kHz sine wave and use dependent sources to generate the non-inverted and inverted 10 mV amplitude sine waves.*
2. Use SPICE to find I_{C1} , I_{C2} , I_{C3} , and $V_{out,DC}$. Compare these values with your calculations from the prelab and measurements in lab.
3. Plot the differential input and differential output signals in Awaves. Print the plot and attach it to your lab worksheet. Use the plot to calculate the gain. Does it match your hand calculations? Does it match your measurements?