



EE105 - Spring 2007 Microelectronic Devices and Circuits

Lecture 5 MOSFET



Metal-Oxide-Semiconductor (MOS) Capacitor

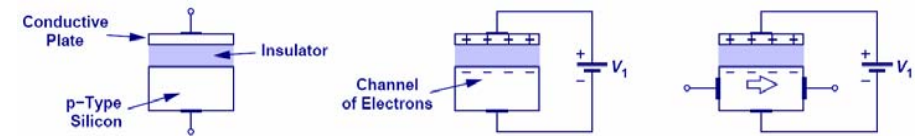

- The MOS structure can be thought of as a parallel-plate capacitor, with the top plate being the positive plate, oxide being the dielectric, and Si substrate being the negative plate. (We are assuming P-substrate.)



Structure and Symbol of MOSFET

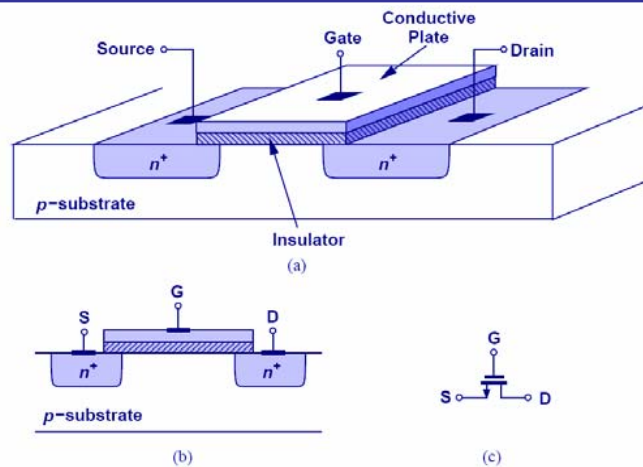

- This device is symmetric, so either of the n+ regions can be source or drain.



State of the Art MOSFET Structure

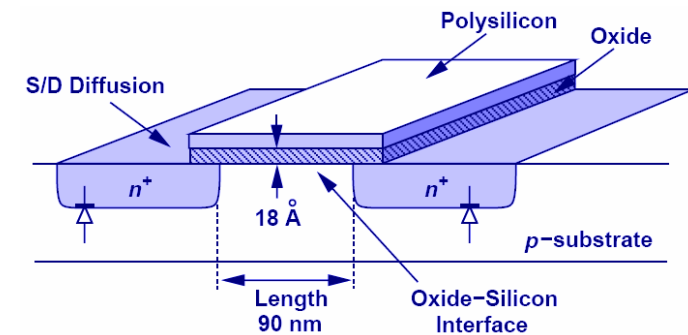

- The gate is formed by polysilicon, and the insulator by Silicon dioxide.



Formation of Channel

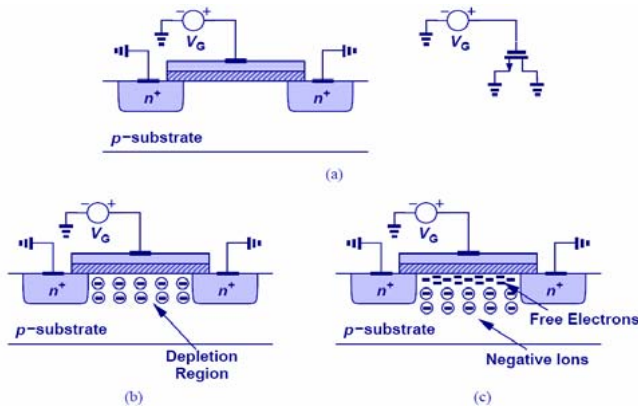

- First, the holes are repelled by the positive gate voltage, leaving behind negative ions and forming a depletion region. Next, electrons are attracted to the interface, creating a channel ("inversion layer").

5



Voltage-Dependent Resistor

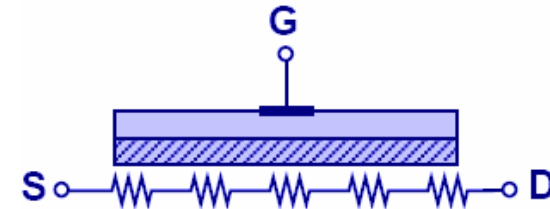

- The inversion channel of a MOSFET can be seen as a resistor.
- Since the charge density inside the channel depends on the gate voltage, this resistance is also voltage-dependent.

6



Voltage-Controlled Attenuator

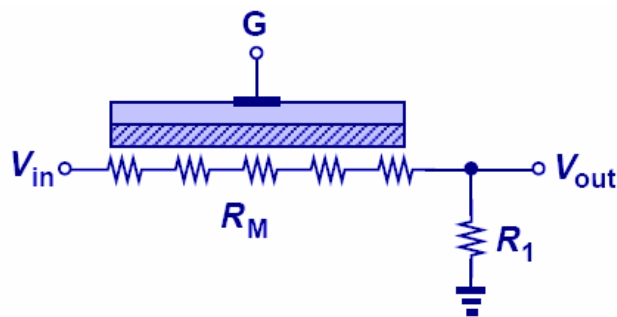

- As the gate voltage decreases, the output drops because the channel resistance increases.
- This type of gain control finds application in cell phones to avoid saturation near base stations.

7



MOSFET Characteristics

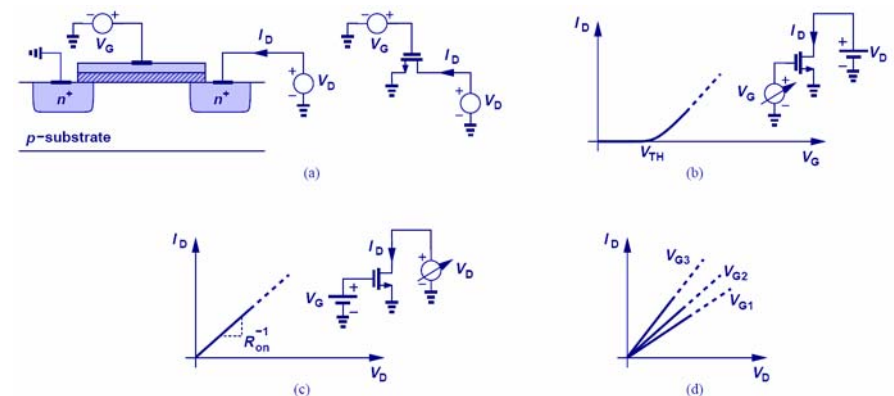

- The MOS characteristics are measured by varying V_G while keeping V_D constant, and varying V_D while keeping V_G constant.
- (d) shows the voltage dependence of channel resistance.

8



L (Gate Length) and t_{ox} (Gate Oxide Thickness) Dependence

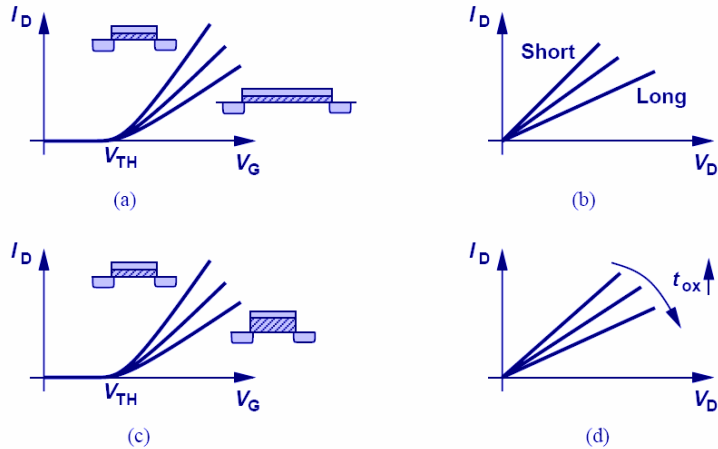

- Small gate length and oxide thickness yield low channel resistance, which will increase the drain current.

9



Effect of Gate Width: W

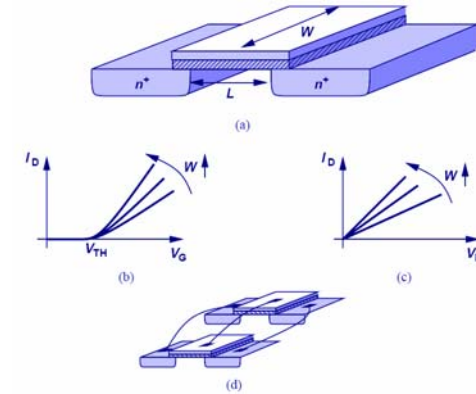

- As the gate width increases, the current increases due to a decrease in resistance. However, gate capacitance also increases thus, limiting the speed of the circuit.
- An increase in W can be seen as two devices in parallel.

10



Channel Potential Variation

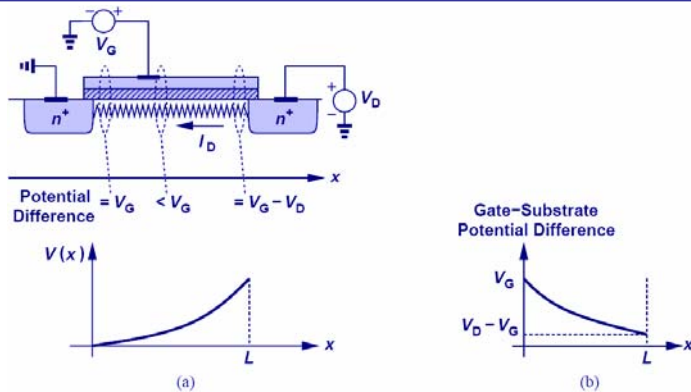

- Since there's a channel resistance between drain and source, and if drain is biased higher than the source, channel potential increases from source to drain, and the potential between gate and channel will decrease from source to drain.

11



Channel Pinch-Off

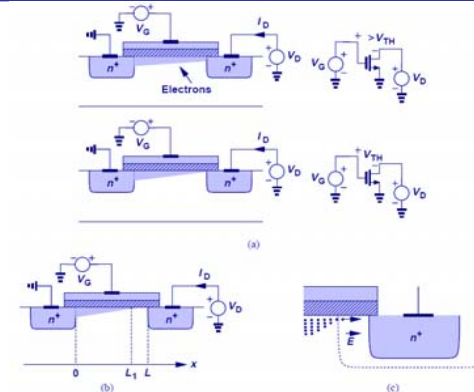

- As the potential difference between drain and gate becomes more positive, the inversion layer beneath the interface starts to pinch off around drain.
- When $V_D - V_G = V_{th}$, the channel at drain totally pinches off, and when $V_D - V_G > V_{th}$, the channel length starts to decrease.

12



Channel Charge Density

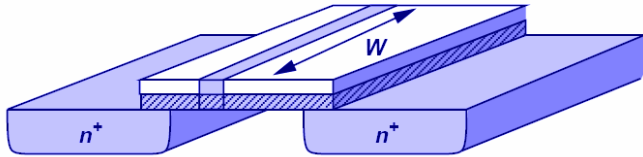

$$Q = WC_{ox}(V_{GS} - V_{TH})$$

- The channel charge density is equal to the gate capacitance times the gate voltage in excess of the threshold voltage.

13



Charge Density at a Point

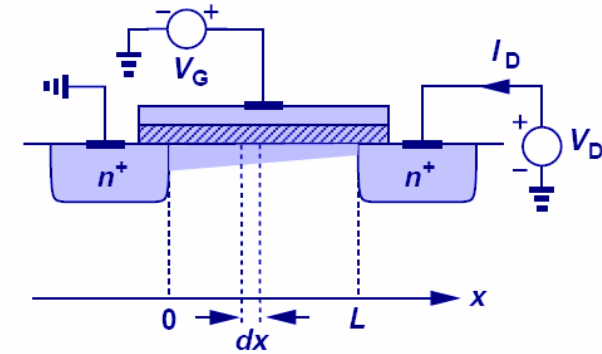

$$Q(x) = WC_{ox}[V_{GS} - V(x) - V_{TH}]$$

- Let x be a point along the channel from source to drain, and $V(x)$ its potential; the expression above gives the charge density (per unit length).

14



Charge Density and Current

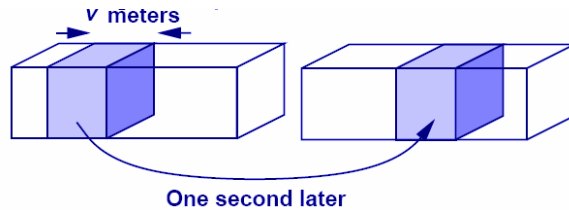

$$I = Q \cdot v$$

- The current that flows from source to drain (electrons) is related to the charge density in the channel by the charge velocity.

15



Drain Current

$$v = +\mu_n \frac{dV}{dx}$$

$$I_D = WC_{ox}[V_{GS} - V(x) - V_{TH}]\mu_n \frac{dV(x)}{dx}$$

$$I_D = \frac{1}{2}\mu_n C_{ox} \frac{W}{L} [2(V_{GS} - V_{TH})V_{DS} - V_{DS}^2]$$

16



Parabolic I_D - V_{DS} Relationship

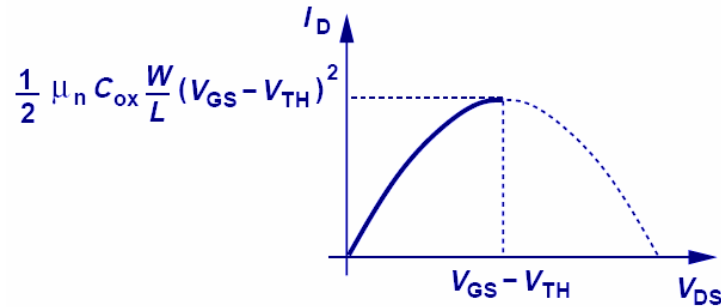

- By keeping V_G constant and varying V_{DS} , we obtain a parabolic relationship.
- The maximum current occurs when V_{DS} equals to $V_{GS} - V_{TH}$.

17



I_D - V_{DS} for Different Values of V_{GS}

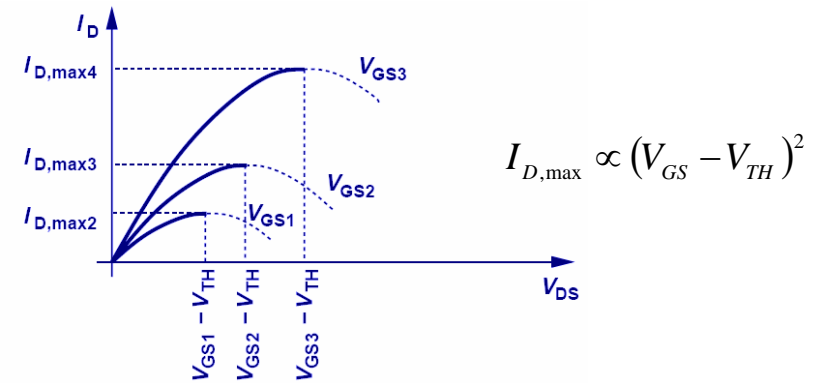

18



Linear Resistance

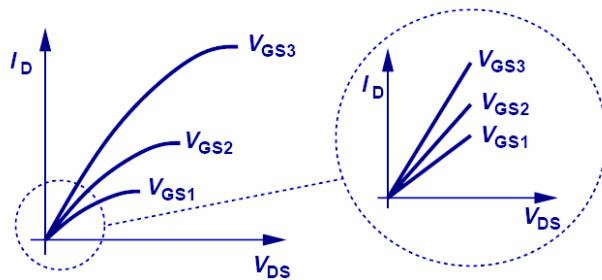

- At small V_{DS} , the transistor can be viewed as a resistor, with the resistance depending on the gate voltage.
- It finds application as an electronic switch.

19



Application of Electronic Switches

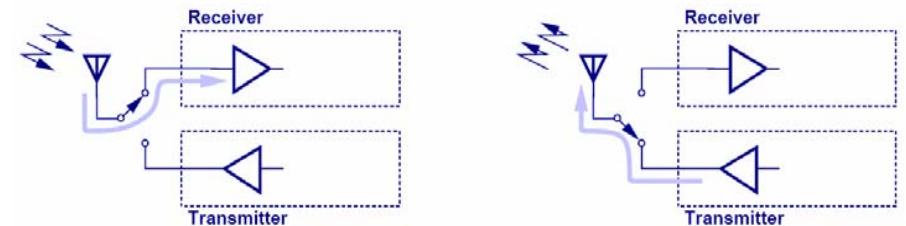

- In a cordless telephone system in which a single antenna is used for both transmission and reception, a switch is used to connect either the receiver or transmitter to the antenna.

20



Effects of On-Resistance

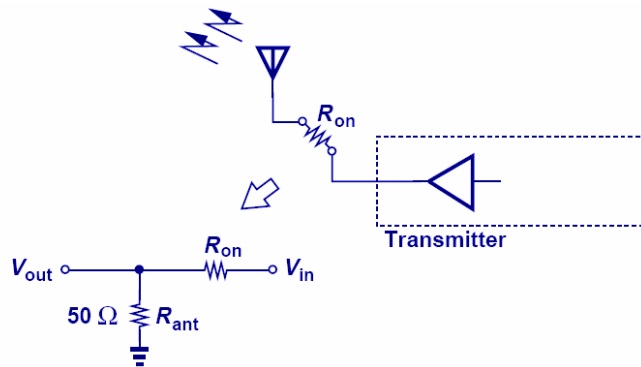

- To minimize signal attenuation, R_{on} of the switch has to be as small as possible. This means larger W/L aspect ratio and greater V_{GS} .

21



Different Regions of Operation

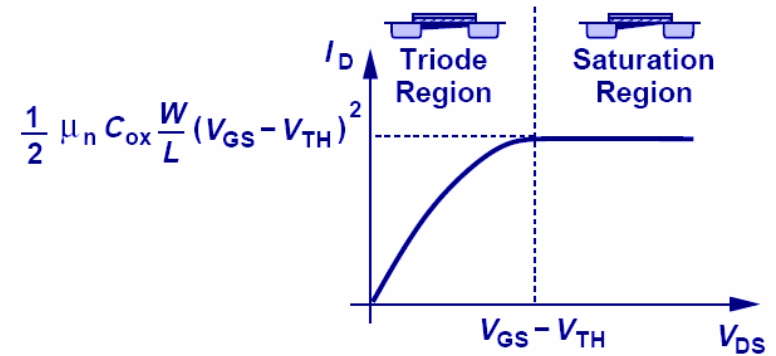

22



How to Determine 'Region of Operation'

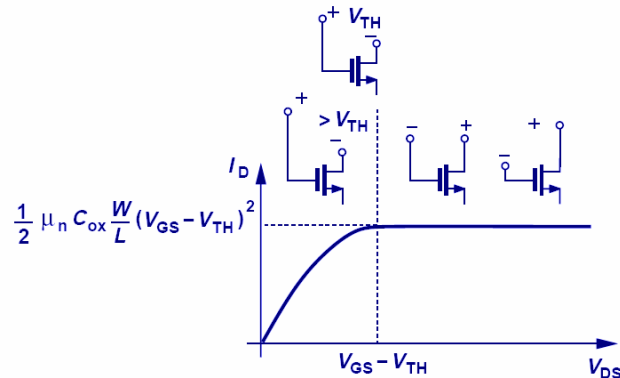

- When the potential difference between gate and drain is greater than V_{TH} , the MOSFET is in triode region.
- When the potential difference between gate and drain becomes equal to or less than V_{TH} , the MOSFET enters saturation region.

23



Triode or Saturation?

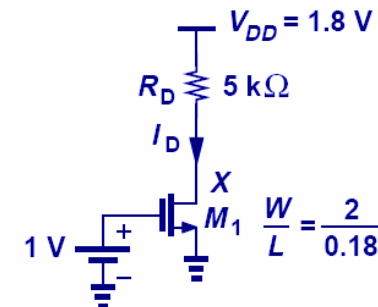

- When the region of operation is not known, a region is assumed (with an intelligent guess). Then, the final answer is checked against the assumption.

24



Channel-Length Modulation

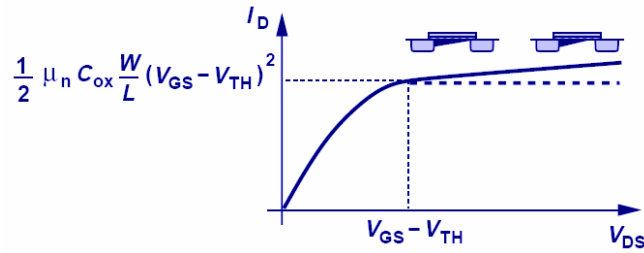

$$I_D = \frac{1}{2} \mu_n C_{ox} \frac{W}{L} (V_{GS} - V_{TH})^2 (1 + \lambda V_{DS})$$

- The original observation that the current is constant in the saturation region is not quite correct. The end point of the channel actually moves toward the source as V_D increases, increasing I_D . Therefore, the current in the saturation region is a weak function of the drain voltage.



λ and L

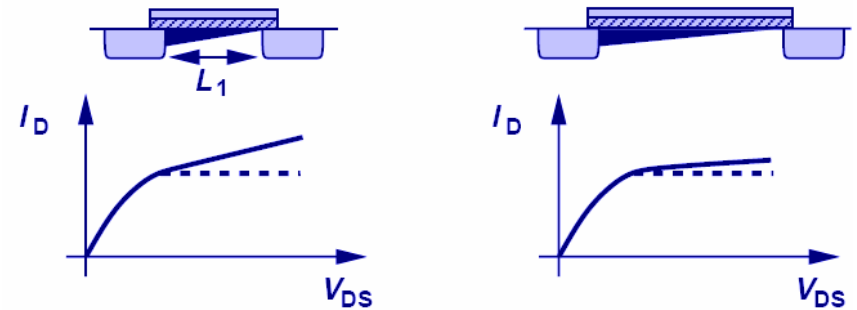

- Unlike the Early voltage in BJT, the channel-length modulation factor can be controlled by the circuit designer.
- For long L, the channel-length modulation effect is less than that of short L.



Transconductance

$\frac{W}{L}$ Constant $V_{GS} - V_{TH}$ Variable	$\frac{W}{L}$ Variable $V_{GS} - V_{TH}$ Constant	$\frac{W}{L}$ Variable $V_{GS} - V_{TH}$ Constant
$g_m \propto \sqrt{I_D}$	$g_m \propto I_D$	$g_m \propto \sqrt{\frac{W}{L}}$
$g_m \propto V_{GS} - V_{TH}$	$g_m \propto \frac{W}{L}$	$g_m \propto \frac{1}{V_{GS} - V_{TH}}$

$$g_m = \mu_n C_{ox} \frac{W}{L} (V_{GS} - V_{TH}) \quad g_m = \sqrt{2C_{ox} \frac{W}{L} I_D} \quad g_m = \frac{2I_D}{V_{GS} - V_{TH}}$$

- Transconductance is a measure of how strong the drain current changes when the gate voltage changes.
- It has three different expressions.



Doubling of g_m Due to Doubling W/L

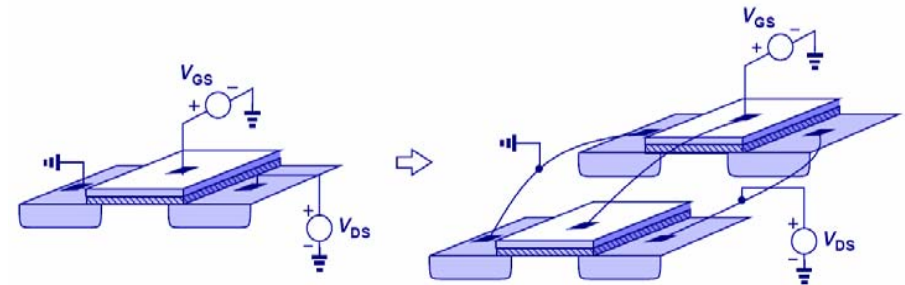

- If W/L is doubled, effectively two equivalent transistors are added in parallel, thus doubling the current (if $V_{GS} - V_{TH}$ is constant) and hence g_m .



Velocity Saturation

$$I_D = v_{sat} \cdot Q = v_{sat} \cdot WC_{ox} (V_{GS} - V_{TH})$$

$$g_m = \frac{\partial I_D}{\partial V_{GS}} = v_{sat} WC_{ox}$$

- Since the channel is very short, it does not take a very large drain voltage to velocity saturate the charge particles.
- In velocity saturation, the drain current becomes a linear function of gate voltage, and gm becomes a function of W.



Body Effect

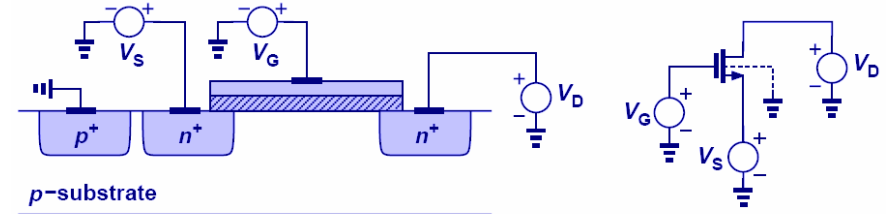

$$V_{TH} = V_{TH0} + \rho(\sqrt{2\phi_F + V_{SB}} - \sqrt{2\phi_F})$$

- As the source potential departs from the bulk potential, the threshold voltage changes.



Large-Signal Models

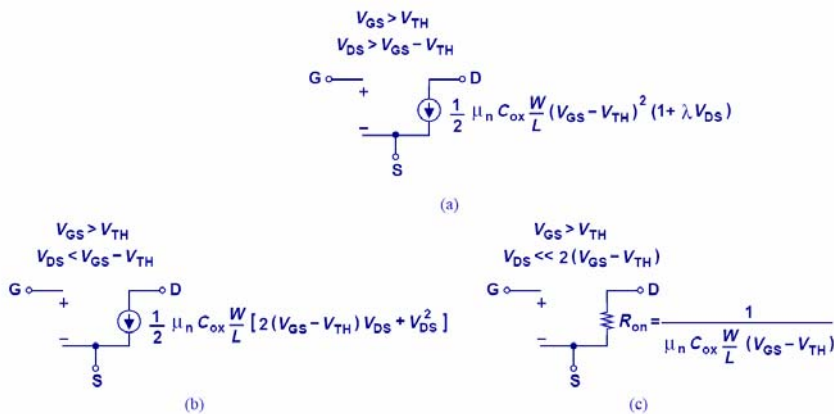

- Based on the value of V_{DS} , MOSFET can be represented with different large-signal models.



Example: Behavior of I_D with V_1 as a Function

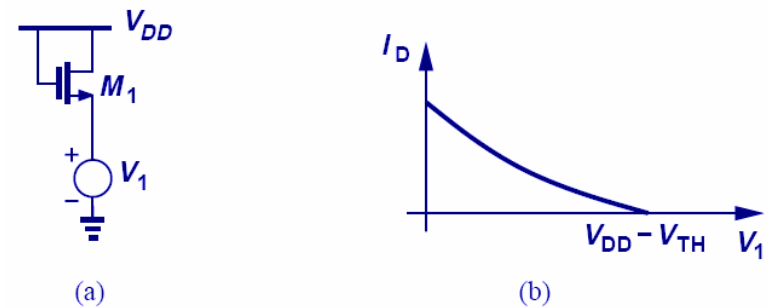

$$I_D = \frac{1}{2} \mu_n C_{ox} \frac{W}{L} (V_{DD} - V_1 - V_{TH})^2$$

- Since V_1 is connected at the source, as it increases, the current drops.



Small-Signal Model

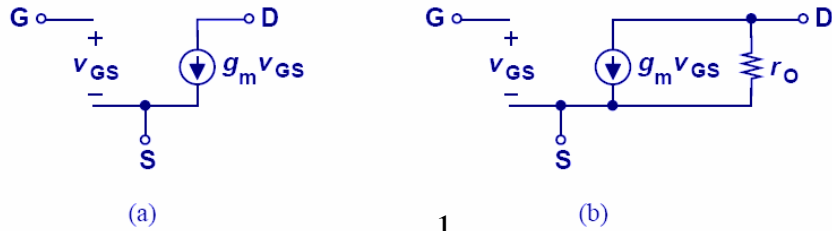

$$r_o \approx \frac{1}{\lambda I_D}$$

- When the bias point is not perturbed significantly, small-signal model can be used to facilitate calculations.
- To represent channel-length modulation, an output resistance is inserted into the model.

33



PMOS Transistor

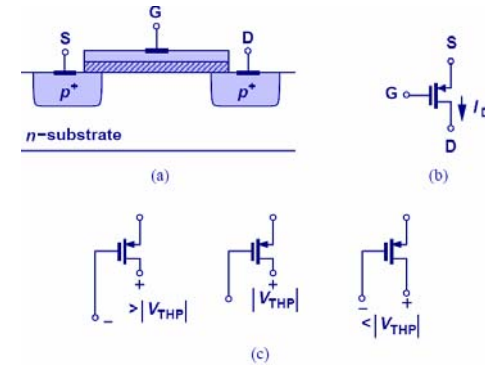

- Just like the PNP transistor in bipolar technology, it is possible to create a MOS device where holes are the dominant carriers. It is called the PMOS transistor.
- It behaves like an NMOS device with all the polarities reversed.

34



PMOS Equations

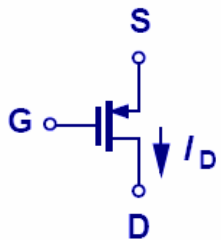

$$I_{D,sat} = \frac{1}{2} \mu_p C_{ox} \frac{W}{L} (V_{GS} - V_{TH})^2 (1 - \lambda V_{DS})$$

$$I_{D,tri} = \frac{1}{2} \mu_p C_{ox} \frac{W}{L} [2(V_{GS} - V_{TH})V_{DS} - V_{DS}^2]$$

$$I_{D,sat} = \frac{1}{2} \mu_p C_{ox} \frac{W}{L} (|V_{GS}| - |V_{TH}|)^2 (1 + \lambda |V_{DS}|)$$

$$I_{D,tri} = \frac{1}{2} \mu_p C_{ox} \frac{W}{L} [2(|V_{GS}| - |V_{TH}|)|V_{DS}| - V_{DS}^2]$$

35



Small-Signal Model of PMOS Device

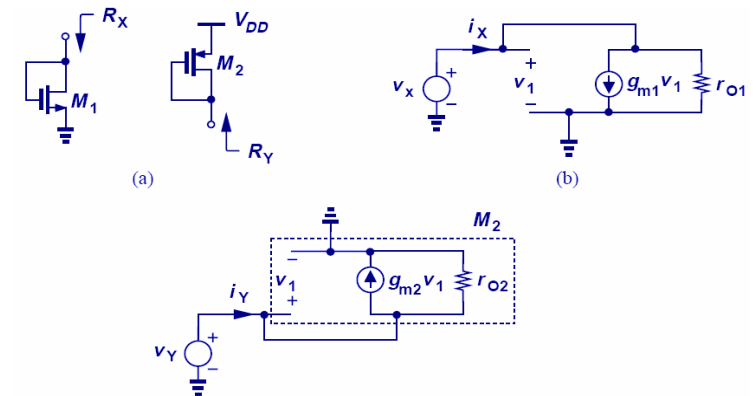

- The small-signal model of PMOS device is identical to that of NMOS transistor; therefore, R_x equals R_y and hence $(1/g_m) || r_o$.

36



CMOS Technology

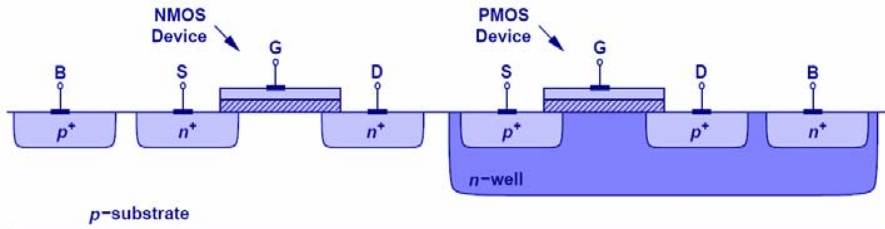

- It is possible to grow an n-well inside a p-substrate to create a technology where both NMOS and PMOS can coexist.
- It is known as CMOS, or "Complementary MOS".

37



Comparison of Bipolar and MOS Transistors

Bipolar Transistor	MOSFET
Exponential Characteristic	Quadratic Characteristic
Active: $V_{CB} > 0$	Saturation: $V_{DS} > V_{GS} - V_{TH}$
Saturation: $V_{CB} < 0$	Triode: $V_{DS} < V_{GS} - V_{TH}$
Finite Base Current	Zero Gate Current
Early Effect	Channel-Length Modulation
Diffusion Current	Drift Current
-	Voltage-Dependent Resistor

- Bipolar devices have a higher g_m than MOSFETs for a given bias current due to its exponential IV characteristics.

38