

Lecture 11

OUTLINE

- Cascode Stage

Reading: Chapter 9.1

EE105 Spring 2008

Lecture 11, Slide 1

Prof. Wu, UC Berkeley

Ideal Current Source

Circuit Symbol

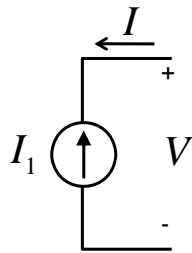

I-V Characteristic

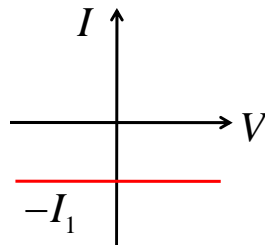

Equivalent Circuit

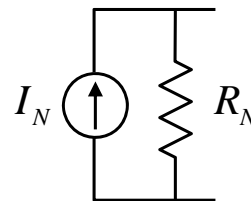

- An ideal current source has infinite output impedance.

How can we increase the output impedance of a BJT that is used as a current source?

EE105 Spring 2008

Lecture 11, Slide 2

Prof. Wu, UC Berkeley

Boosting the Output Impedance

- Recall that emitter degeneration boosts the impedance seen looking into the collector.
 - This improves the gain of the CE or CB amplifier. **However, headroom is reduced.**

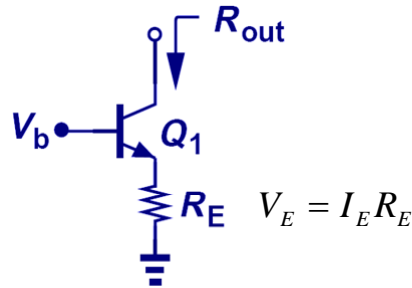

$$R_{out} = [1 + g_m (R_E \parallel r_\pi)] r_O + R_E \parallel r_\pi$$

EE105 Spring 2008

Lecture 11, Slide 3

Prof. Wu, UC Berkeley

Cascode Stage

- In order to relax the trade-off between output impedance and voltage headroom, we can use a transistor instead of a degeneration resistor:

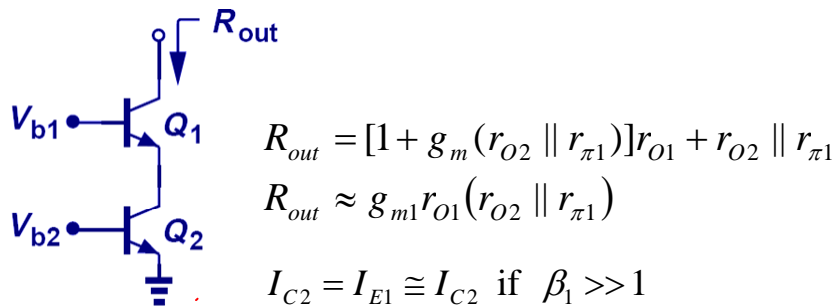

$$R_{out} = [1 + g_m (r_{O2} \parallel r_{\pi1})] r_{O1} + r_{O2} \parallel r_{\pi1}$$

$$R_{out} \approx g_{m1} r_{O1} (r_{O2} \parallel r_{\pi1})$$

$$I_{C2} = I_{E1} \cong I_{C1} \text{ if } \beta_1 \gg 1$$

- V_{CE} for Q_2 can be as low as $\sim 0.4V$ ("soft saturation")

EE105 Spring 2008

Lecture 11, Slide 4

Prof. Wu, UC Berkeley

Maximum Bipolar Cascode Output Impedance

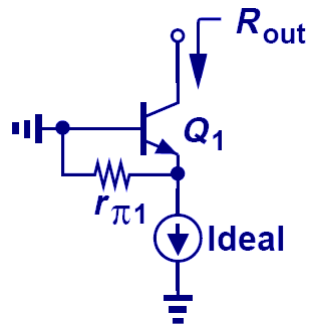

$$R_{out,max} \approx g_{m1} r_{o1} r_{\pi 1}$$

$$R_{out,max} \approx \beta_1 r_{o1}$$

- The maximum output impedance of a bipolar cascode is bounded by the ever-present r_{π} between emitter and ground of Q_1 .

EE105 Spring 2008

Lecture 11, Slide 5

Prof. Wu, UC Berkeley

PNP Cascode Stage

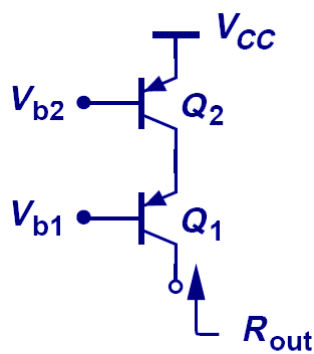

$$R_{out} = [1 + g_m (r_{o2} \parallel r_{\pi 1})] r_{o1} + r_{o2} \parallel r_{\pi 1}$$

$$R_{out} \approx g_{m1} r_{o1} (r_{o2} \parallel r_{\pi 1})$$

EE105 Spring 2008

Lecture 11, Slide 6

Prof. Wu, UC Berkeley

False Cascodes

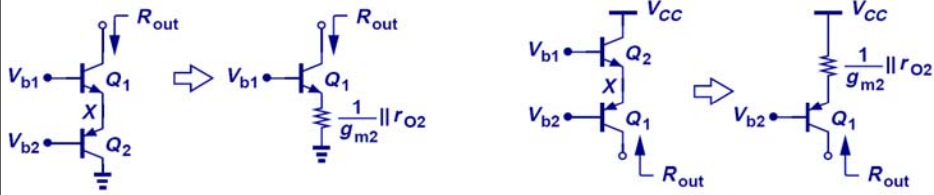

$$R_{out} = \left[1 + g_{m1} \left(\frac{1}{g_{m2}} \parallel r_{O2} \parallel r_{\pi1} \right) \right] r_{O1} + \frac{1}{g_{m2}} \parallel r_{O2} \parallel r_{\pi1}$$

$$R_{out} \approx \left(1 + \frac{g_{m1}}{g_{m2}} \right) r_{O1} + \frac{1}{g_{m2}} \approx 2r_{O1}$$

- When the emitter of Q_1 is connected to the emitter of Q_2 , it's no longer a cascode since Q_2 becomes a diode-connected device instead of a current source.

EE105 Spring 2008

Lecture 11, Slide 7

Prof. Wu, UC Berkeley

Short-Circuit Transconductance

- The **short-circuit transconductance** of a circuit is a measure of its strength in converting an input voltage signal into an output current signal.

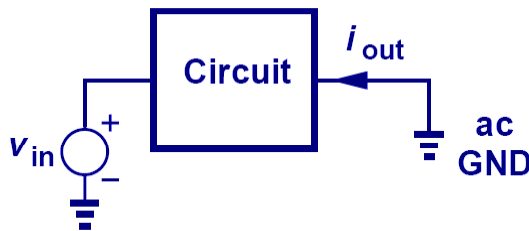

$$G_m \equiv \left. \frac{i_{out}}{v_{in}} \right|_{v_{out}=0}$$

EE105 Spring 2008

Lecture 11, Slide 8

Prof. Wu, UC Berkeley

Voltage Gain of a Linear Circuit

- By representing a linear circuit with its Norton equivalent, the relationship between V_{out} and V_{in} can be expressed by the product of G_m and R_{out} .

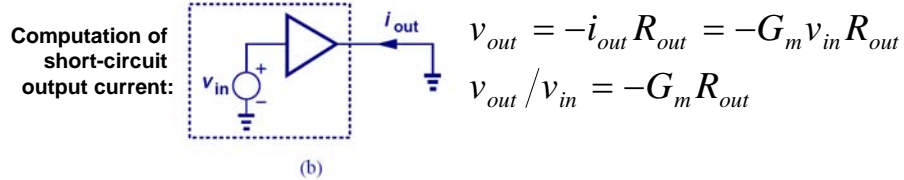
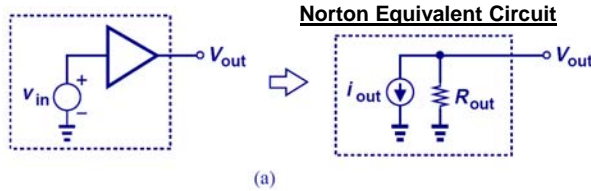

EE10

Prof. Wu, UC Berkeley

Example: Voltage Gain

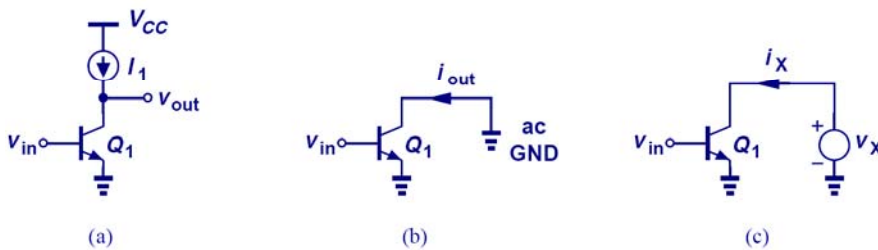

$$G_m \equiv \left. \frac{i_{out}}{v_{in}} \right|_{v_{out}=0} = g_{m1} \qquad R_{out} \equiv \frac{v_x}{i_x} = r_{o1}$$

$$A_v = -g_{m1} r_{o1}$$

EE105 Spring 2008

Lecture 11, Slide 10

Prof. Wu, UC Berkeley

Comparison of CE and Cascode Stages

- Since the output impedance of the cascode is higher than that of a CE stage, its voltage gain is also higher.

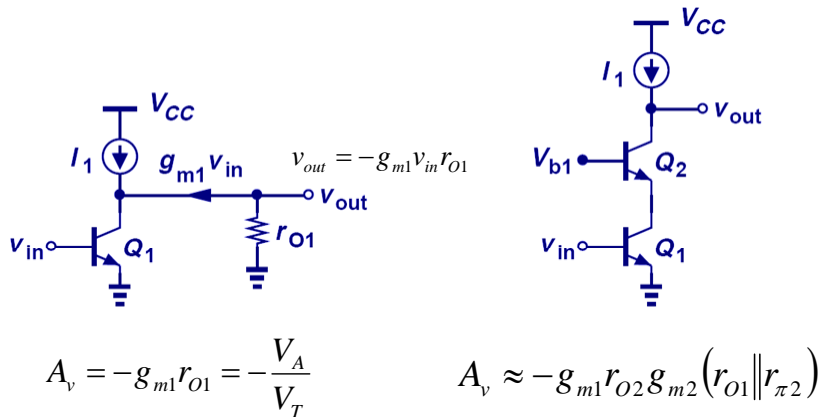

EE105 Spring 2008

Lecture 11, Slide 11

Prof. Wu, UC Berkeley

Voltage Gain of Cascode Amplifier

- Since r_{O1} is much larger than $1/g_{m1}$, most of $I_{C,Q1}$ flows into diode-connected Q_2 . Using R_{out} as before, A_v is easily calculated.

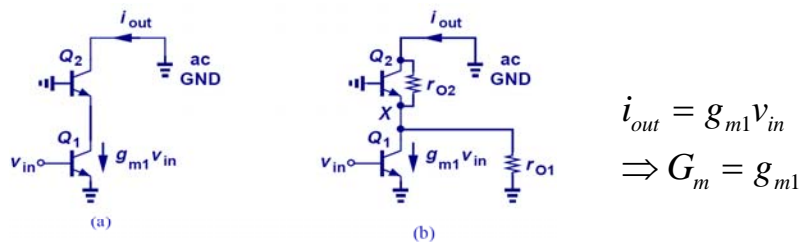

$$A_v = -G_m R_{out}$$

$$= -g_{m1} [(1 + g_{m2} (r_{O1} \parallel r_{\pi 2})) r_{O2} + r_{O1} \parallel r_{\pi 2}]$$

$$\approx -g_{m1} [g_{m2} (r_{O1} \parallel r_{\pi 2}) r_{O2}]$$

EE105 Spring 2008

Lecture 11, Slide 12

Prof. Wu, UC Berkeley

Alternate View of Cascode Amplifier

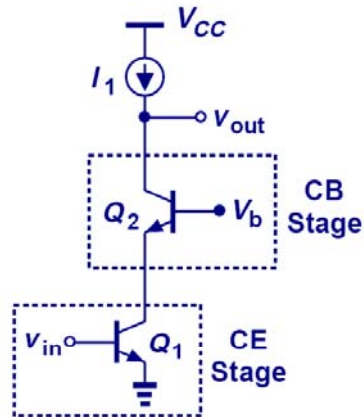

- A bipolar cascode amplifier is also a CE stage in series with a CB stage.

EE105 Spring 2008

Lecture 11, Slide 13

Prof. Wu, UC Berkeley

Practical Cascode Stage

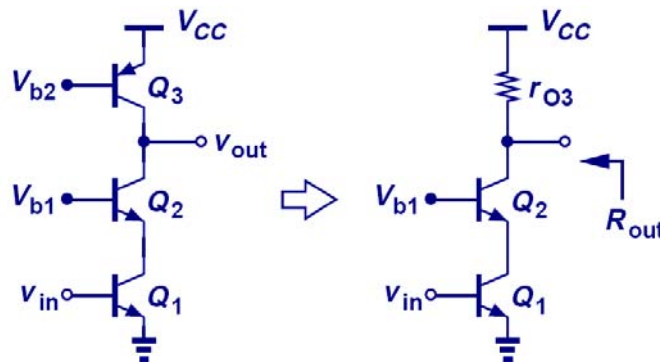

$$R_{out} \approx r_{O3} \parallel g_{m2}r_{O2}(r_{O1} \parallel r_{\pi 2})$$

- Since no current source can be ideal, the output impedance drops.

EE105 Spring 2008

Lecture 11, Slide 14

Prof. Wu, UC Berkeley

Improved Cascode Stage

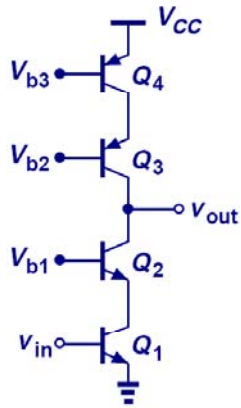

$$R_{out} \approx [g_{m3}r_{O3}(r_{O4} \parallel r_{\pi3})] \parallel [g_{m2}r_{O2}(r_{O1} \parallel r_{\pi2})]$$

$$A_v = -g_{m1}R_{out}$$

- In order to preserve the high output impedance, a cascode PNP current source is used.