

Lecture 16

OUTLINE

- MOSFET structure & operation (qualitative)
- Large-signal I-V characteristics
- Channel length modulation
- Small-signal model
- Reading: Chapter 6.1-6.3

EE105 Spring 2008

Lecture 16, Slide 1

Prof. Wu, UC Berkeley

Metal-Oxide-Semiconductor (MOS) Capacitor

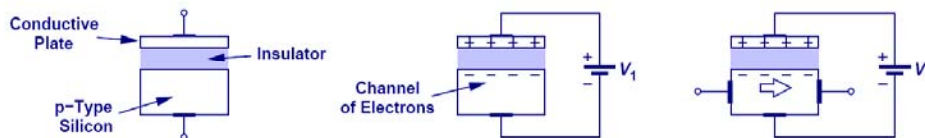

- The MOS structure can be thought of as a parallel-plate capacitor, with the top plate being the positive plate, oxide being the dielectric, and Si substrate being the negative plate. (We are assuming P-substrate.)

EE105 Spring 2008

Lecture 16, Slide 2

Prof. Wu, UC Berkeley

Structure and Symbol of MOSFET

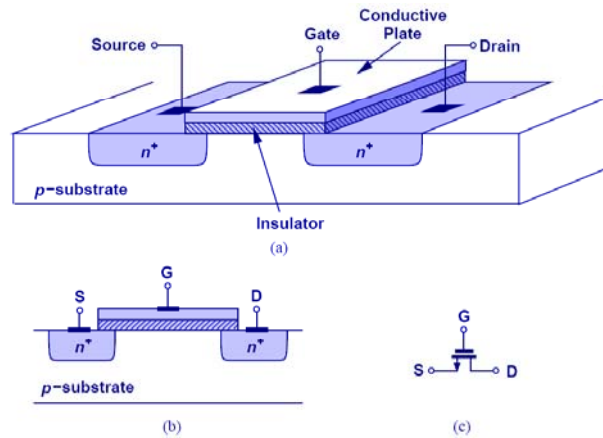

- This device is symmetric, so either of the n+ regions can be source or drain.

EE105 Spring 2008

Lecture 16, Slide 3

Prof. Wu, UC Berkeley

State of the Art MOSFET Structure

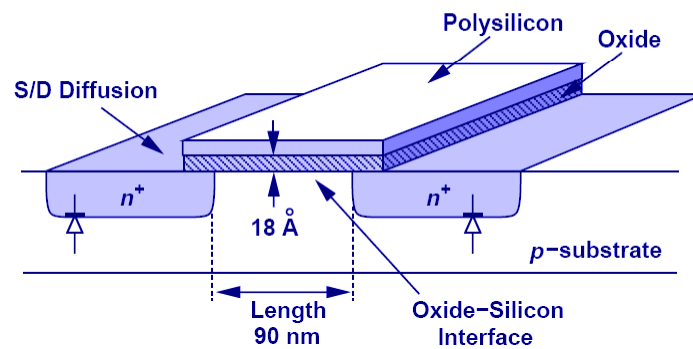

- The gate is formed by polysilicon, and the insulator by Silicon dioxide.

EE105 Spring 2008

Lecture 16, Slide 4

Prof. Wu, UC Berkeley

Formation of Channel

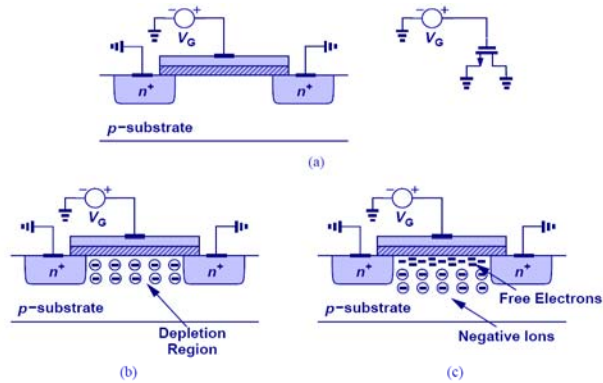

- First, the holes are repelled by the positive gate voltage, leaving behind negative ions and forming a depletion region. Next, electrons are attracted to the interface, creating a channel (“inversion layer”).

EE105 Spring 2008

Lecture 16, Slide 5

Prof. Wu, UC Berkeley

Voltage-Dependent Resistor

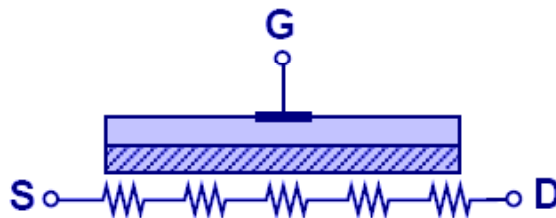

- The inversion channel of a MOSFET can be seen as a resistor.
- Since the charge density inside the channel depends on the gate voltage, this resistance is also voltage-dependent.

EE105 Spring 2008

Lecture 16, Slide 6

Prof. Wu, UC Berkeley

Voltage-Controlled Attenuator

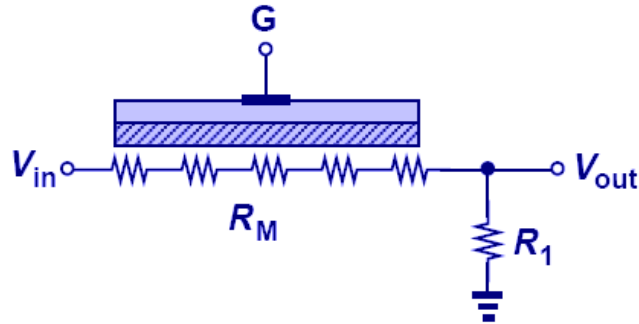

- As the gate voltage decreases, the output drops because the channel resistance increases.
- This type of gain control finds application in cell phones to avoid saturation near base stations.

EE105 Spring 2008

Lecture 16, Slide 7

Prof. Wu, UC Berkeley

MOSFET Characteristics

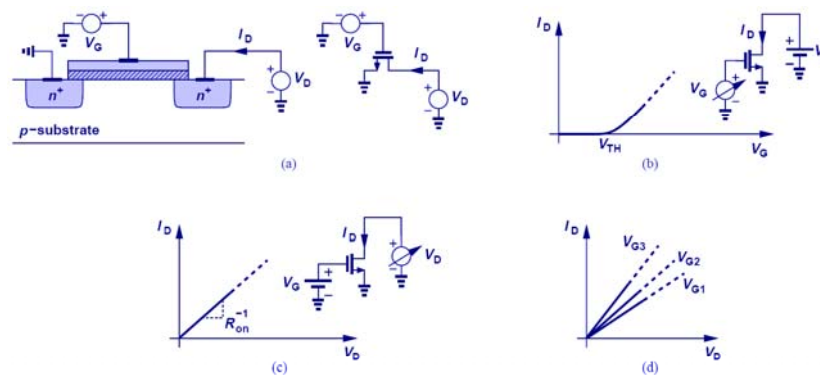

- The MOS characteristics are measured by varying V_G while keeping V_D constant, and varying V_D while keeping V_G constant.
- (d) shows the voltage dependence of channel resistance.

EE105 Spring 2008

Lecture 16, Slide 8

Prof. Wu, UC Berkeley

L (Gate Length) and t_{ox} (Gate Oxide Thickness) Dependence

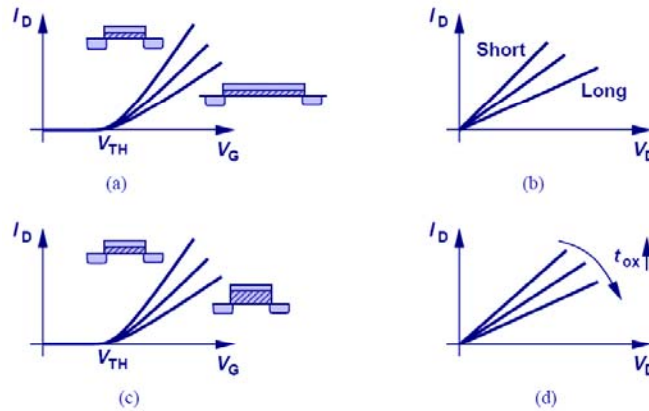

- Small gate length and oxide thickness yield low channel resistance, which will increase the drain current.

EE105 Spring 2008

Lecture 16, Slide 9

Prof. Wu, UC Berkeley

Effect of Gate Width: W

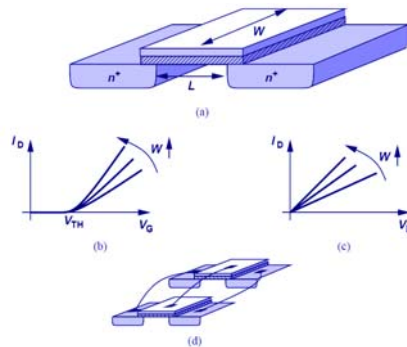

- As the gate width increases, the current increases due to a decrease in resistance. However, gate capacitance also increases thus, limiting the speed of the circuit.
- An increase in W can be seen as two devices in parallel.

EE105 Spring 2008

Lecture 16, Slide 10

Prof. Wu, UC Berkeley

Channel Potential Variation

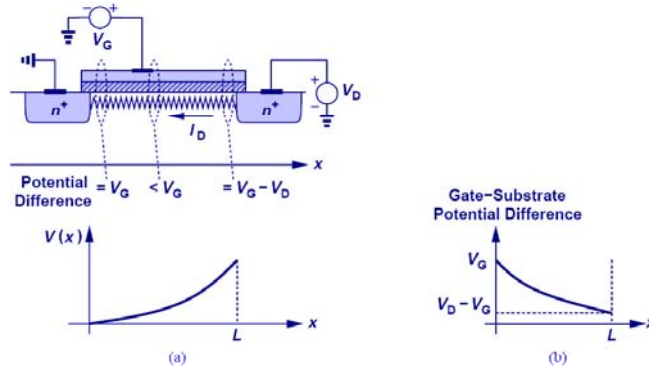

- Since there's a channel resistance between drain and source, and if drain is biased higher than the source, channel potential increases from source to drain, and the potential between gate and channel will decrease from source to drain.

EE105 Spring 2008

Lecture 16, Slide 11

Prof. Wu, UC Berkeley

Channel Pinch-Off

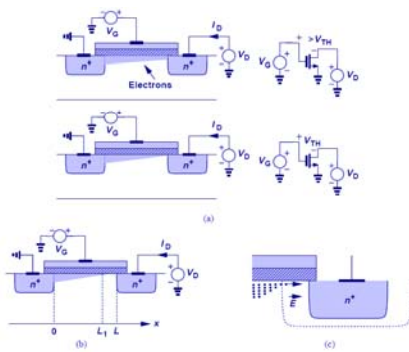

- As the potential difference between drain and gate becomes more positive, the inversion layer beneath the interface starts to pinch off around drain.
- When $V_D - V_G = V_{th}$, the channel at drain totally pinches off, and when $V_D - V_G > V_{th}$, the channel length starts to decrease.

EE105 Spring 2008

Lecture 16, Slide 12

Prof. Wu, UC Berkeley

Channel Charge Density

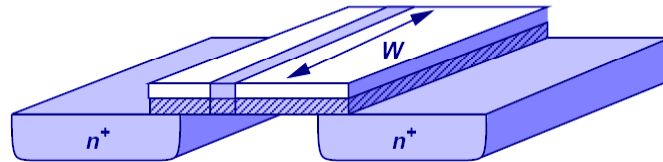

$$Q = WC_{ox}(V_{GS} - V_{TH})$$

- The channel charge density is equal to the gate capacitance times the gate voltage in excess of the threshold voltage.

EE105 Spring 2008

Lecture 16, Slide 13

Prof. Wu, UC Berkeley

Charge Density at a Point

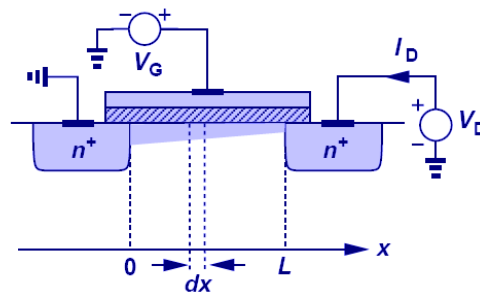

$$Q(x) = WC_{ox}[V_{GS} - V(x) - V_{TH}]$$

- Let x be a point along the channel from source to drain, and $V(x)$ its potential; the expression above gives the charge density (per unit length).

EE105 Spring 2008

Lecture 16, Slide 14

Prof. Wu, UC Berkeley

Parabolic I_D - V_{DS} Relationship

$$I_D = Q \cdot v$$

$$Q(x) = WC_{ox} [V_{GS} - V(x) - V_{TH}]$$

$$v = +\mu_n \frac{dV}{dx}$$

$$I_D = WC_{ox} [V_{GS} - V(x) - V_{TH}] \mu_n \frac{dV(x)}{dx}$$

$$I_D = \frac{1}{2} \mu_n C_{ox} \frac{W}{L} [2(V_{GS} - V_{TH})V_{DS} - V_{DS}^2]$$

- By keeping V_G constant and varying V_{DS} , we obtain a parabolic relationship.
- The maximum current occurs when V_{DS} equals to $V_{GS} - V_{TH}$.

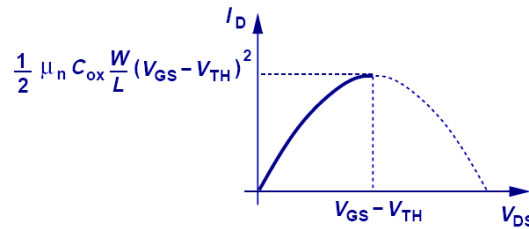

EE105 Spring 2008

Lecture 16, Slide 15

Prof. Wu, UC Berkeley

I_D - V_{DS} for Different Values of V_{GS}

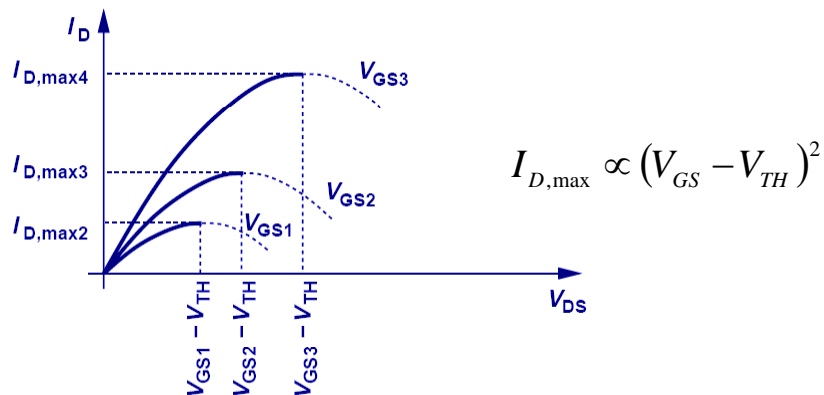

EE105 Spring 2008

Lecture 16, Slide 16

Prof. Wu, UC Berkeley

Linear Resistance

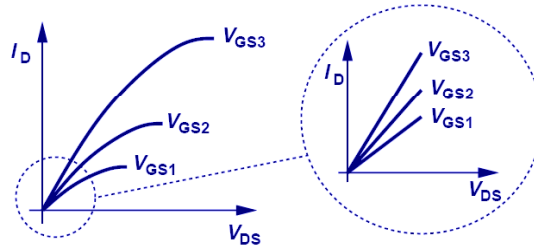

$$R_{on} = \frac{1}{\mu_n C_{ox} \frac{W}{L} (V_{GS} - V_{TH})}$$

- At small V_{DS} , the transistor can be viewed as a resistor, with the resistance depending on the gate voltage.
- It finds application as an electronic switch.

EE105 Spring 2008

Lecture 16, Slide 17

Prof. Wu, UC Berkeley

Application of Electronic Switches

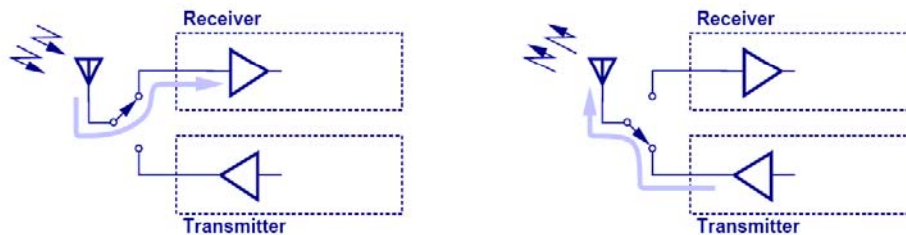

- In a cordless telephone system in which a single antenna is used for both transmission and reception, a switch is used to connect either the receiver or transmitter to the antenna.

EE105 Spring 2008

Lecture 16, Slide 18

Prof. Wu, UC Berkeley

Effects of On-Resistance

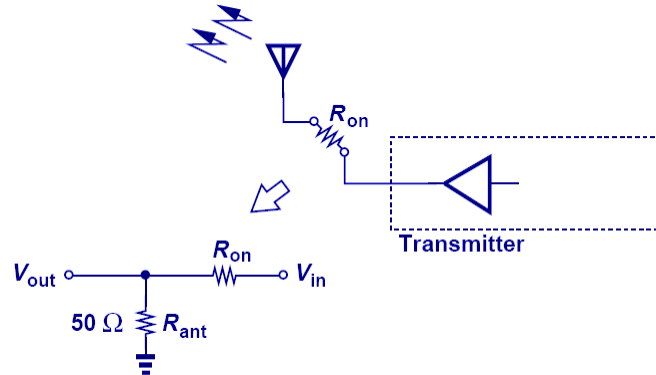

- To minimize signal attenuation, R_{on} of the switch has to be as small as possible. This means larger W/L aspect ratio and greater V_{GS} .

EE105 Spring 2008

Lecture 16, Slide 19

Prof. Wu, UC Berkeley

Different Regions of Operation

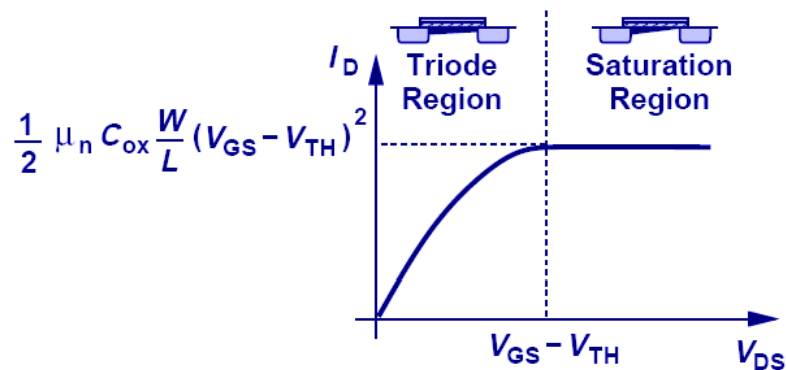

EE105 Spring 2008

Lecture 16, Slide 20

Prof. Wu, UC Berkeley

How to Determine 'Region of Operation'

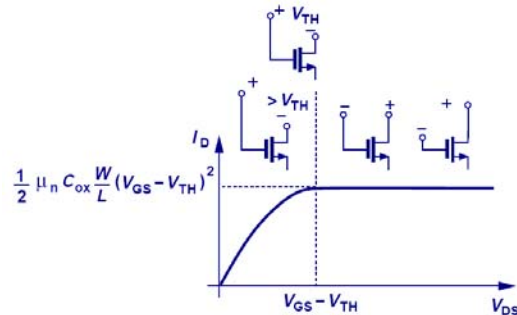

- When the potential difference between gate and drain is greater than V_{TH} , the MOSFET is in triode region.
- When the potential difference between gate and drain becomes equal to or less than V_{TH} , the MOSFET enters saturation region.

EE105 Spring 2008

Lecture 16, Slide 21

Prof. Wu, UC Berkeley

Triode or Saturation?

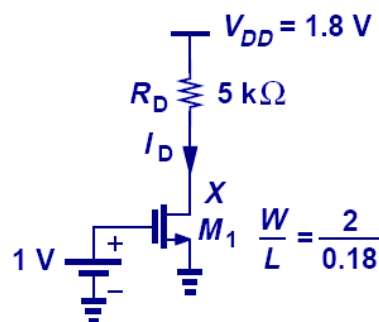

- When the region of operation is not known, a region is assumed (with an intelligent guess). Then, the final answer is checked against the assumption.

EE105 Spring 2008

Lecture 16, Slide 22

Prof. Wu, UC Berkeley

Channel-Length Modulation

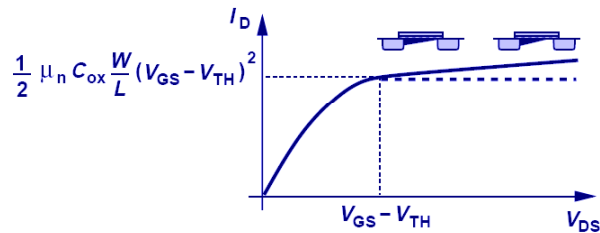

$$I_D = \frac{1}{2} \mu_n C_{ox} \frac{W}{L} (V_{GS} - V_{TH})^2 (1 + \lambda V_{DS})$$

- The original observation that the current is constant in the saturation region is not quite correct. The end point of the channel actually moves toward the source as V_D increases, increasing I_D . Therefore, the current in the saturation region is a weak function of the drain voltage.

EE105 Spring 2008

Lecture 16, Slide 23

Prof. Wu, UC Berkeley

λ and L

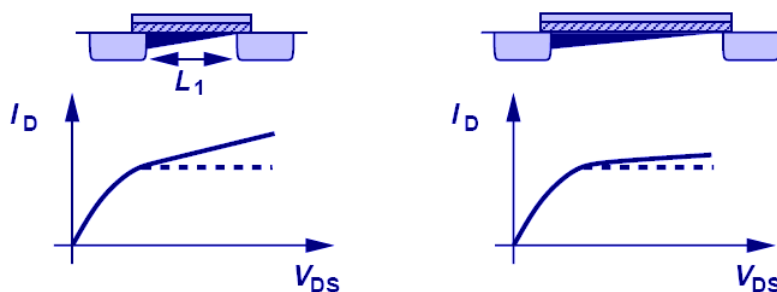

- Unlike the Early voltage in BJT, the channel-length modulation factor can be controlled by the circuit designer.
- For long L, the channel-length modulation effect is less than that of short L.

EE105 Spring 2008

Lecture 16, Slide 24

Prof. Wu, UC Berkeley

Transconductance

$\frac{W}{L}$ Constant $V_{GS} - V_{TH}$ Variable	$\frac{W}{L}$ Variable $V_{GS} - V_{TH}$ Constant	$\frac{W}{L}$ Variable $V_{GS} - V_{TH}$ Constant
$g_m \propto \sqrt{I_D}$	$g_m \propto I_D$	$g_m \propto \sqrt{\frac{W}{L}}$
$g_m \propto V_{GS} - V_{TH}$	$g_m \propto \frac{W}{L}$	$g_m \propto \frac{1}{V_{GS} - V_{TH}}$

$$g_m = \mu_n C_{ox} \frac{W}{L} (V_{GS} - V_{TH}) \quad g_m = \sqrt{2\mu_n C_{ox} \frac{W}{L} I_D} \quad g_m = \frac{2I_D}{V_{GS} - V_{TH}}$$

- Transconductance is a measure of how strong the drain current changes when the gate voltage changes.
- It has three different expressions.

EE105 Spring 2008

Lecture 16, Slide 25

Prof. Wu, UC Berkeley

Velocity Saturation

$$I_D = v_{sat} \cdot Q = v_{sat} \cdot WC_{ox} (V_{GS} - V_{TH})$$

$$g_m = \frac{\partial I_D}{\partial V_{GS}} = v_{sat} WC_{ox}$$

- Since the channel is very short, it does not take a very large drain voltage to velocity saturate the charge particles.
- In velocity saturation, the drain current becomes a linear function of gate voltage, and g_m becomes a function of W .

EE105 Spring 2008

Lecture 16, Slide 26

Prof. Wu, UC Berkeley

Body Effect

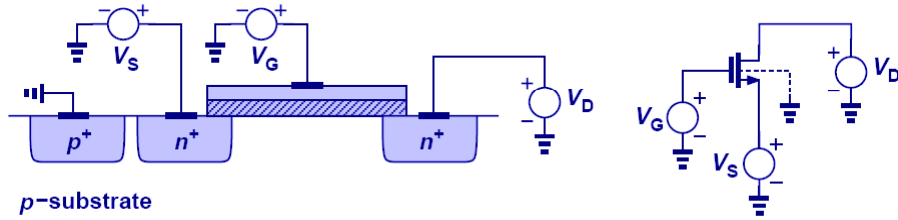

$$V_{TH} = V_{TH0} + \gamma \left(\sqrt{|2\phi_F| + V_{SB}} - \sqrt{|2\phi_F|} \right)$$

- As the source potential departs from the bulk potential, the threshold voltage changes.

EE105 Spring 2008

Lecture 16, Slide 27

Prof. Wu, UC Berkeley

Large-Signal Models

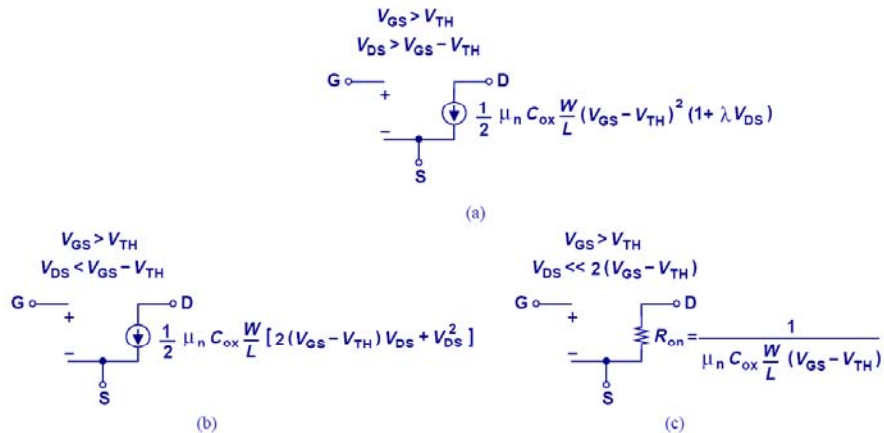

- Based on the value of V_{DS} , MOSFET can be represented with different large-signal models.

EE105 Spring 2008

Lecture 16, Slide 28

Prof. Wu, UC Berkeley

Example: Behavior of I_D with V_1 as a Function

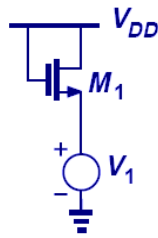

(a)

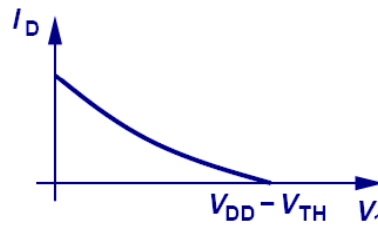

(b)

$$I_D = \frac{1}{2} \mu_n C_{ox} \frac{W}{L} (V_{DD} - V_1 - V_{TH})^2$$

- Since V_1 is connected at the source, as it increases, the current drops.

EE105 Spring 2008

Lecture 16, Slide 29

Prof. Wu, UC Berkeley

Small-Signal Model

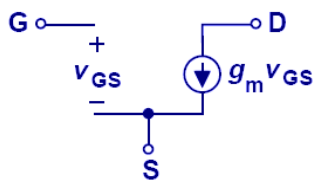

(a)

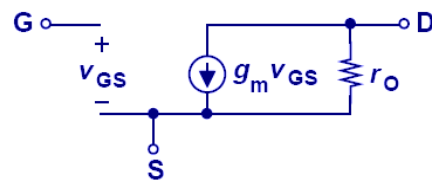

(b)

$$r_o \approx \frac{1}{\lambda I_D}$$

- When the bias point is not perturbed significantly, small-signal model can be used to facilitate calculations.
- To represent channel-length modulation, an output resistance is inserted into the model.

EE105 Spring 2008

Lecture 16, Slide 30

Prof. Wu, UC Berkeley

PMOS Transistor

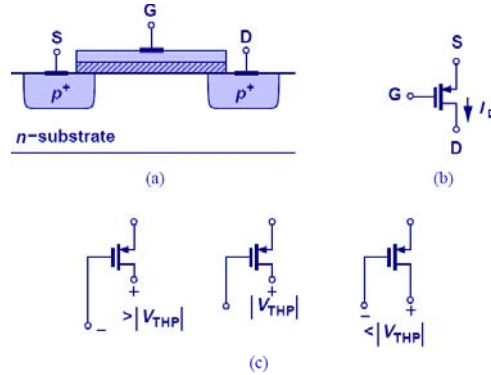

- Just like the PNP transistor in bipolar technology, it is possible to create a MOS device where holes are the dominant carriers. It is called the PMOS transistor.
- It behaves like an NMOS device with all the polarities reversed.

EE105 Spring 2008

Lecture 16, Slide 31

Prof. Wu, UC Berkeley

PMOS Equations

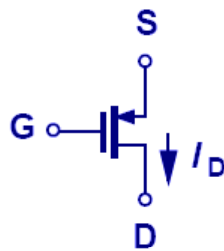

$$I_{D,sat} = \frac{1}{2} \mu_p C_{ox} \frac{W}{L} (V_{GS} - V_{TH})^2 (1 - \lambda V_{DS})$$

$$I_{D,tri} = \frac{1}{2} \mu_p C_{ox} \frac{W}{L} [2(V_{GS} - V_{TH})V_{DS} - V_{DS}^2]$$

$$I_{D,sat} = \frac{1}{2} \mu_p C_{ox} \frac{W}{L} (|V_{GS}| - |V_{TH}|)^2 (1 + \lambda |V_{DS}|)$$

$$I_{D,tri} = \frac{1}{2} \mu_p C_{ox} \frac{W}{L} [2(|V_{GS}| - |V_{TH}|)|V_{DS}| - V_{DS}^2]$$

EE105 Spring 2008

Lecture 16, Slide 32

Prof. Wu, UC Berkeley

Small-Signal Model of PMOS Device

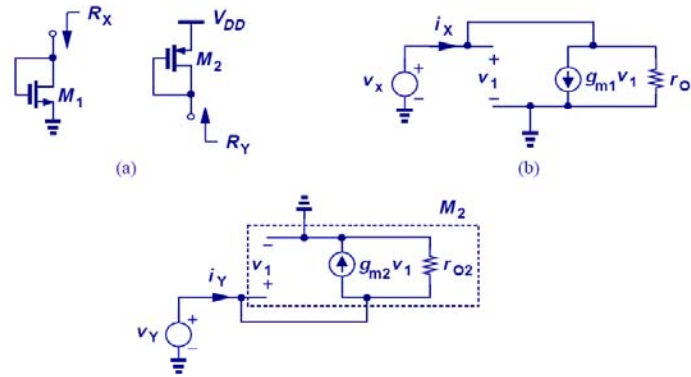

- The small-signal model of PMOS device is identical to that of NMOS transistor; therefore, R_X equals R_Y and hence $(1/g_m) || r_o$.

EE105 Spring 2008

Lecture 16, Slide 33

Prof. Wu, UC Berkeley

CMOS Technology

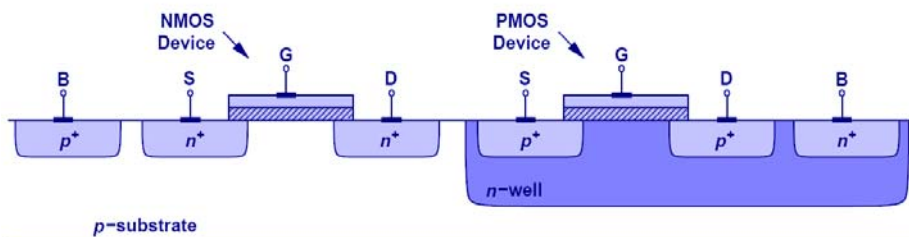

- It is possible to grow an n-well inside a p-substrate to create a technology where both NMOS and PMOS can coexist.
- It is known as CMOS, or "Complementary MOS".

EE105 Spring 2008

Lecture 16, Slide 34

Prof. Wu, UC Berkeley

Comparison of Bipolar and MOS Transistors

Bipolar Transistor	MOSFET
Exponential Characteristic Active: $V_{CB} > 0$ Saturation: $V_{CB} < 0$ Finite Base Current Early Effect Diffusion Current -	Quadratic Characteristic Saturation: $V_{DS} > V_{GS} - V_{TH}$ Triode: $V_{DS} < V_{GS} - V_{TH}$ Zero Gate Current Channel-Length Modulation Drift Current Voltage-Dependent Resistor

- Bipolar devices have a higher g_m than MOSFETs for a given bias current due to its exponential IV characteristics.