

Lecture 18

OUTLINE

- Basic MOSFET amplifier
- MOSFET biasing
- MOSFET current sources
- Common-source amplifier

- Reading: Chap. 7.1-7.2

EE105 Spring 2008

Lecture 18, Slide 1

Prof. Wu, UC Berkeley

Common-Source Stage

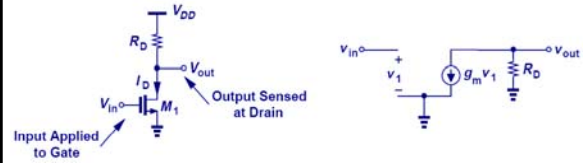

$$\lambda = 0$$

$$A_v = -g_m R_D$$

$$A_v = -\sqrt{2\mu_n C_{ox} \frac{W}{L}} I_D R_D$$

EE105 Spring 2008

Lecture 18, Slide 2

Prof. Wu, UC Berkeley

Operation in Saturation

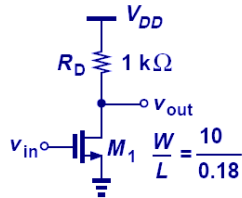

Condition for M_1 in saturation
 $V_{out} > V_{in} - V_{TH}$

$$\Rightarrow V_{DD} - R_D I_D > (V_{GS} - V_{TH})$$

- In order to maintain operation in saturation, V_{out} cannot fall below V_{in} by more than one threshold voltage.
- The condition above ensures operation in saturation.

EE105 Spring 2008

Lecture 18, Slide 3

Prof. Wu, UC Berkeley

CS Stage with $\lambda=0$

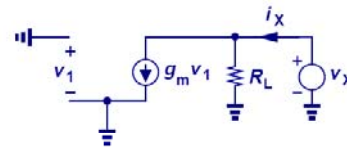

$$A_v = -g_m R_L$$

$$R_{in} = \infty$$

$$R_{out} = R_L$$

EE105 Spring 2008

Lecture 18, Slide 4

Prof. Wu, UC Berkeley

CS Stage with $\lambda \neq 0$

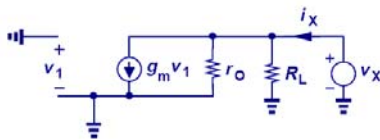

$$A_v = -g_m (R_L \parallel r_o)$$

$$R_{in} = \infty$$

$$R_{out} = R_L \parallel r_o$$

- However, channel length modulation leads to finite output resistance, r_o , which is in parallel with the load resistance, R_L

EE105 Spring 2008

Lecture 18, Slide 5

Prof. Wu, UC Berkeley

CS Gain Variation with Channel Length

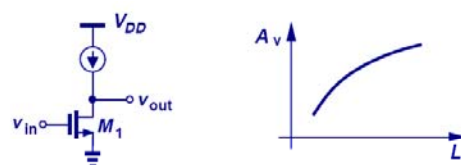

$$|A_v| = \frac{\sqrt{2\mu_n C_{ox} \frac{W}{L}}}{\lambda \sqrt{I_D}} \propto \sqrt{\frac{2\mu_n C_{ox} W L}{I_D}}$$

- Since λ is inversely proportional to L , the intrinsic voltage gain actually becomes proportional to the square root of L .

EE105 Spring 2008

Lecture 18, Slide 6

Prof. Wu, UC Berkeley

MOS Biasing

$$\frac{R_1}{R_1 + R_2} V_{DD} = V_{GS} + I_D R_S$$

$$I_D = \frac{1}{2} \mu_n C_{ox} \frac{W}{L} (V_{GS} - V_{TH})^2$$

2 unknowns (V_{GS} , I_D), 2 equations \Rightarrow

$$V_{GS} = -(V_i - V_{TH}) + \sqrt{V_i^2 + 2V_i \left(\frac{R_S V_{DD}}{R_1 + R_2} - V_{TH} \right)}$$

$$V_i = \frac{1}{\mu_n C_{ox} \frac{W}{L} R_S}$$

- Voltage at X is determined by V_{DD} , R_1 , and R_2 .
- V_{GS} can be found using the equation above, and I_D can be found by using the NMOS current equation.

EE105 Spring 2008 Lecture 18, Slide 7 Prof. Wu, UC Berkeley

Self-Biased MOS Stage

$$I_D R_D + V_{GS} + R_S I_D = V_{DD}$$

$$I_D = \frac{1}{2} \mu_n C_{ox} \frac{W}{L} (V_{GS} - V_{TH})^2$$

- The circuit above is analyzed by noting M_1 is in saturation and no potential drop appears across R_G .

EE105 Spring 2008 Lecture 18, Slide 8 Prof. Wu, UC Berkeley

Current Sources

(a)

(b)

(c)

(d)

- When in saturation region, a MOSFET behaves as a current source.
- NMOS draws current from a point to ground (sinks current), whereas PMOS draws current from V_{DD} to a point (sources current).

EE105 Spring 2008 Lecture 18, Slide 9 Prof. Wu, UC Berkeley

CS Stage with Current-Source Load

$$A_v = -g_{m1} (r_{O1} \parallel r_{O2})$$

$$R_{out} = r_{O1} \parallel r_{O2}$$

- To alleviate the headroom problem, an active current-source load is used.
- This is advantageous because a current-source has a high output resistance and can tolerate a small voltage drop across it.

EE105 Spring 2008 Lecture 18, Slide 10 Prof. Wu, UC Berkeley

PMOS CS Stage with NMOS as Load

$$A_v = -g_{m2} (r_{O1} \parallel r_{O2})$$

- Similarly, with PMOS as input stage and NMOS as the load, the voltage gain is the same as before.

EE105 Spring 2008 Lecture 18, Slide 11 Prof. Wu, UC Berkeley

CS Stage with Diode-Connected Load

$$A_v = -g_{m1} \left(\frac{1}{g_{m2}} \parallel r_{O2} \parallel r_{O1} \right)$$

$$A_v = -g_{m1} \cdot \frac{1}{g_{m2}} = -\sqrt{\frac{(W/L)_1}{(W/L)_2}}$$

- Lower gain, but less dependent on process parameters.

EE105 Spring 2008 Lecture 18, Slide 12 Prof. Wu, UC Berkeley

CS Stage with Diode-Connected PMOS Device

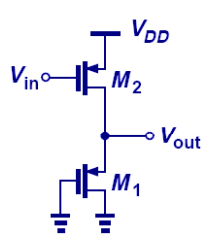

$$A_v = -g_{m2} \left(\frac{1}{g_{m1}} \parallel r_{o1} \parallel r_{o2} \right)$$

- Note that PMOS circuit symbol is usually drawn with the source on top of the drain.

EE105 Spring 2008 Lecture 18, Slide 13 Prof. Wu, UC Berkeley

CS Stage with Degeneration

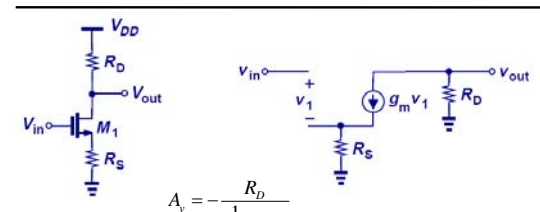

$$A_v = -\frac{R_D}{\frac{1}{g_m} + R_S}$$

$$\lambda = 0$$

- Similar to bipolar counterpart, when a CS stage is degenerated, its gain, I/O impedances, and linearity change.

EE105 Spring 2008 Lecture 18, Slide 14 Prof. Wu, UC Berkeley

Example of CS Stage with Degeneration

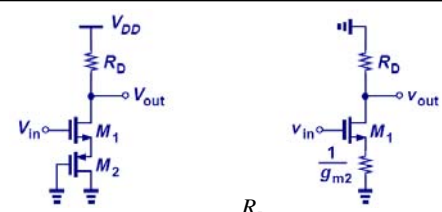

$$A_v = -\frac{R_D}{\frac{1}{g_{m1}} + \frac{1}{g_{m2}}}$$

- A diode-connected device degenerates a CS stage.

EE105 Spring 2008 Lecture 18, Slide 15 Prof. Wu, UC Berkeley

CS Stage with Gate Resistance

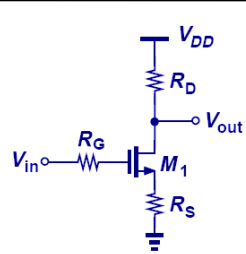

$$V_{R_G} = 0$$

- Since at low frequencies, the gate conducts no current, gate resistance does not affect the gain or I/O impedances.

EE105 Spring 2008 Lecture 18, Slide 16 Prof. Wu, UC Berkeley

Output Impedance of CS Stage with Degeneration

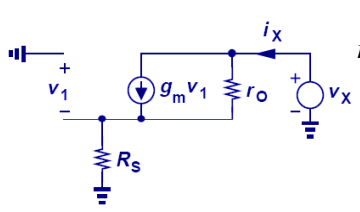

$$r_{out} \approx g_m r_O R_S + r_O$$

- Similar to the bipolar counterpart, degeneration boosts output impedance.

EE105 Spring 2008 Lecture 18, Slide 17 Prof. Wu, UC Berkeley

Output Impedance Example (I)

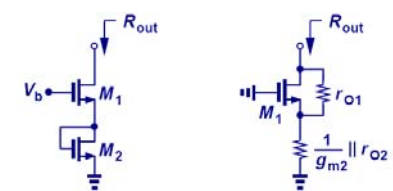

$$R_{out} = r_{O1} \left(1 + g_{m1} \frac{1}{g_{m2}} \right)$$

- When $1/g_m$ is parallel with r_{O2} , we often just consider $1/g_m$

EE105 Spring 2008 Lecture 18, Slide 18 Prof. Wu, UC Berkeley

Output Impedance Example (II)

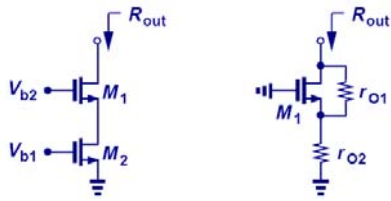

$$R_{out} \approx g_{m1} r_{O1} r_{O2} + r_{O1}$$

- In this example, the impedance that degenerates the CS stage is r_{O2} , instead of $1/g_m$ in the previous example.

EE105 Spring 2008

Lecture 18, Slide 19

Prof. Wu, UC Berkeley

CS Core with Biasing

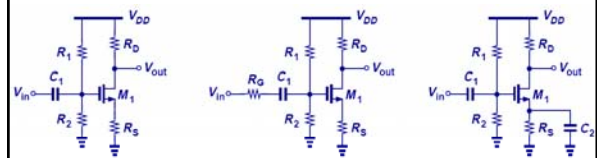

$$A_v = \frac{R_1 \parallel R_2}{R_G + R_1 \parallel R_2} \cdot \frac{-R_D}{\frac{1}{g_m} + R_5}$$

$$A_v = -g_m R_D$$

- Degeneration is used to stabilize bias point, and a bypass capacitor can be used to obtain a larger small-signal voltage gain at the frequency of interest.

EE105 Spring 2008

Lecture 18, Slide 20

Prof. Wu, UC Berkeley