

Lecture 21

OUTLINE

- Frequency Response
 - Review of basic concepts
 - high-frequency MOSFET model
 - CS stage
 - CG stage
 - Source follower
 - Cascode stage
- Reading: Chapter 11

EE105 Spring 2008

Lecture 21, Slide 1

Prof. Wu, UC Berkeley

A_v Roll-Off due to C_L

- The impedance of C_L decreases at high frequencies, so that it shunts some of the output current to ground.

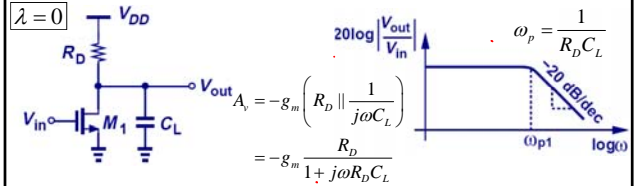

- In general, if **node j in the signal path** has a small-signal resistance of R_j to ground and a capacitance C_j to ground, then it contributes a **pole at frequency $(R_j C_j)^{-1}$**

EE105 Spring 2008

Lecture 21, Slide 2

Prof. Wu, UC Berkeley

Pole Identification Example 1

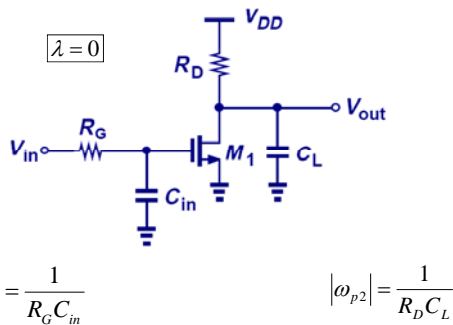

EE105 Spring 2008

Lecture 21, Slide 3

Prof. Wu, UC Berkeley

Pole Identification Example 2

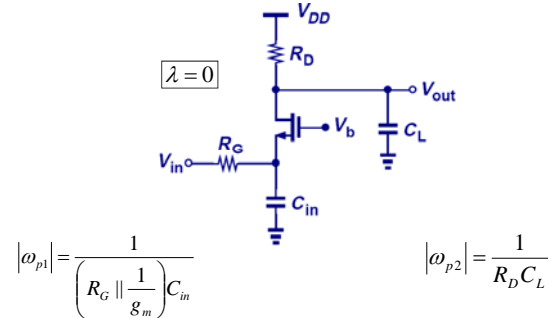

EE105 Spring 2008

Lecture 21, Slide 4

Prof. Wu, UC Berkeley

Dealing with a Floating Capacitance

- Recall that a pole is computed by finding the resistance and capacitance between a node and (AC) GROUND.
- It is not straightforward to compute the pole due to C_F in the circuit below, because neither of its terminals is grounded.

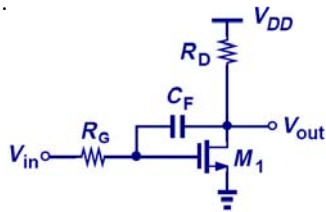

EE105 Spring 2008

Lecture 21, Slide 5

Prof. Wu, UC Berkeley

Miller's Theorem

- If A_v is the voltage gain from node 1 to 2, then a floating impedance Z_F can be converted to two grounded impedances Z_1 and Z_2 :

$$\frac{V_1 - V_2}{Z_F} = \frac{V_1}{Z_1} \Rightarrow Z_1 = Z_F \frac{V_1}{V_1 - V_2} = Z_F \frac{1}{1 - A_v}$$

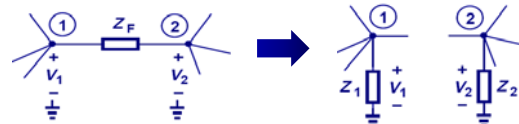

$$\frac{V_1 - V_2}{Z_F} = -\frac{V_2}{Z_2} \Rightarrow Z_2 = -Z_F \frac{V_2}{V_1 - V_2} = Z_F \frac{1}{1 - 1/A_v}$$

EE105 Spring 2008

Lecture 21, Slide 6

Prof. Wu, UC Berkeley

Miller Multiplication

- Applying Miller's theorem, we can convert a floating capacitance between the input and output nodes of an amplifier into two grounded capacitances.
- The capacitance at the input node is larger than the original floating capacitance.

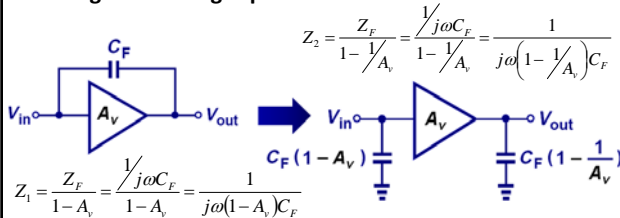

EE105 Spring 2008

Lecture 21, Slide 7

Prof. Wu, UC Berkeley

Application of Miller's Theorem

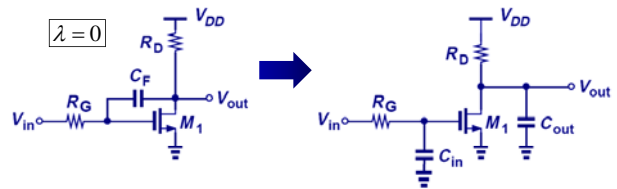

$$\omega_{in} = \frac{1}{R_G(1 + g_m R_D)C_F}$$

$$\omega_{out} = \frac{1}{R_D\left(1 + \frac{1}{g_m R_D}\right)C_F}$$

EE105 Spring 2008

Lecture 21, Slide 8

Prof. Wu, UC Berkeley

MOSFET Intrinsic Capacitances

The MOSFET has intrinsic capacitances which affect its performance at high frequencies:

1. gate oxide capacitance between the gate and channel,
2. overlap and fringing capacitances between the gate and the source/drain regions, and
3. source-bulk & drain-bulk junction capacitances (C_{SB} & C_{DB}).

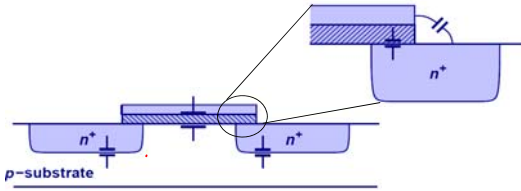

EE105 Spring 2008

Lecture 21, Slide 9

Prof. Wu, UC Berkeley

High-Frequency MOSFET Model

- The gate oxide capacitance can be decomposed into a capacitance between the gate and the source (C_1) and a capacitance between the gate and the drain (C_2).

- In saturation, $C_1 \cong (2/3) \times C_{gate}$, and $C_2 \cong 0$. ($C_{gate} = C_{ox}WL$)
- C_1 in parallel with the source overlap/fringing capacitance $\rightarrow C_{GS}$
- C_2 in parallel with the drain overlap/fringing capacitance $\rightarrow C_{GD}$

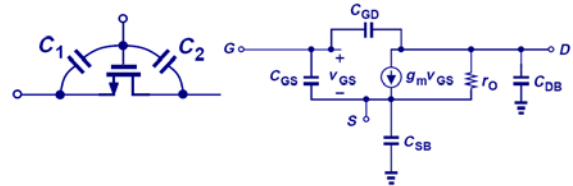

EE105 Spring 2008

Lecture 21, Slide 10

Prof. Wu, UC Berkeley

Example

CS stage

...with MOSFET capacitances explicitly shown

Simplified circuit for high-frequency analysis

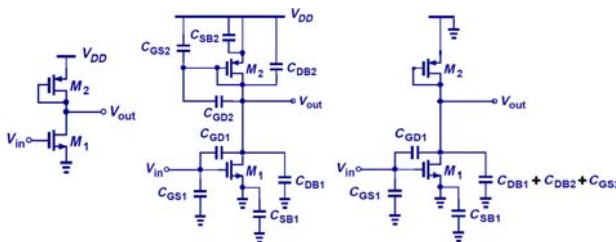

EE105 Spring 2008

Lecture 21, Slide 11

Prof. Wu, UC Berkeley

Transit Frequency

- The "transit" or "cut-off" frequency, f_T , is a measure of the intrinsic speed of a transistor, and is defined as the frequency where the current gain falls to 1.

Conceptual set-up to measure f_T

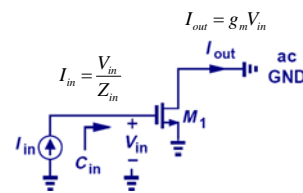

$$\left| \frac{I_{out}}{I_{in}} \right| = |g_m Z_{in}| = \left| g_m \left(\frac{1}{j\omega C_{in}} \right) \right| = 1$$

$$\Rightarrow \omega_T = \frac{g_m}{C_{in}}$$

$$2\pi f_T = \frac{g_m}{C_{GS}}$$

EE105 Spring 2008

Lecture 21, Slide 12

Prof. Wu, UC Berkeley

Small-Signal Model for CS Stage

$\lambda = 0$

EE105 Spring 2008 Lecture 21, Slide 13 Prof. Wu, UC Berkeley

... Applying Miller's Theorem

$V_{Thev} = V_{in}$
 $R_{Thev} = R_G$
 $C_X = C_{GD} (1 + g_m R_D)$
 $C_Y = C_{GD} (1 + \frac{1}{g_m R_D})$

$\omega_{p,in} = \frac{1}{R_{Thev} (C_{in} + (1 + g_m R_D) C_{GD})}$
 $\omega_{p,out} = \frac{1}{R_D (C_{out} + (1 + \frac{1}{g_m R_D}) C_{GD})}$

Note that $\omega_{p,out} > \omega_{p,in}$

EE105 Spring 2008 Lecture 21, Slide 14 Prof. Wu, UC Berkeley

Direct Analysis of CS Stage

- Direct analysis yields slightly different pole locations and an extra zero:

$$\omega_z = \frac{g_m}{C_{XY}}$$

$$\omega_{p1} = \frac{1}{(1 + g_m R_D) C_{XY} R_{Thev} + R_{Thev} C_{in} + R_D (C_{XY} + C_{out})}$$

$$\omega_{p2} = \frac{(1 + g_m R_D) C_{XY} R_{Thev} + R_{Thev} C_{in} + R_D (C_{XY} + C_{out})}{R_{Thev} R_D (C_{in} C_{XY} + C_{out} C_{XY} + C_{in} C_{out})}$$

EE105 Spring 2008 Lecture 21, Slide 15 Prof. Wu, UC Berkeley

I/O Impedances of CS Stage

$\lambda = 0$

$Z_{in} \approx \frac{1}{j\omega [C_{GS} + (1 + g_m R_D) C_{GD}]}$

$Z_{out} = \frac{1}{j\omega [C_{GD} + C_{DB}]} \parallel R_D$

EE105 Spring 2008 Lecture 21, Slide 16 Prof. Wu, UC Berkeley

CG Stage: Pole Frequencies

CG stage with MOSFET capacitances shown

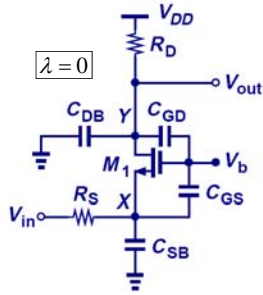

$$\omega_{p,X} = \frac{1}{\left(R_S \parallel \frac{1}{g_m}\right) C_X}$$

$$C_X = C_{GS} + C_{SB}$$

$$\omega_{p,Y} = \frac{1}{R_D C_Y}$$

$$C_Y = C_{GD} + C_{DB}$$

EE105 Spring 2008

Lecture 21, Slide 17

Prof. Wu, UC Berkeley

AC Analysis of Source Follower

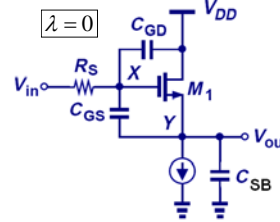

- The transfer function of a source follower can be obtained by direct AC analysis, similarly as for the emitter follower

$$\frac{v_{out}}{v_{in}} = \frac{1 + (j\omega) \frac{C_{GS}}{g_m}}{a(j\omega)^2 + b(j\omega) + 1}$$

$$a = \frac{R_S}{g_m} (C_{GD} C_{GS} + C_{GD} C_{SB} + C_{GS} C_{SB})$$

$$b = R_S C_{GD} + \frac{C_{GD} + C_{SB}}{g_m}$$

EE105 Spring 2008

Lecture 21, Slide 18

Prof. Wu, UC Berkeley

Example

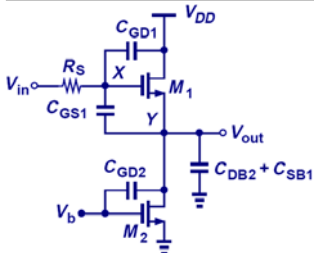

$$\frac{v_{out}}{v_{in}} = \frac{1 + (j\omega) \frac{C_{GS}}{g_m}}{a(j\omega)^2 + b(j\omega) + 1}$$

$$a = \frac{R_S}{g_{m1}} [C_{GD1} C_{GS1} + (C_{GD1} + C_{GS1})(C_{SB1} + C_{GD2} + C_{DB2})]$$

$$b = R_S C_{GD1} + \frac{C_{GD1} + C_{SB1} + C_{GD2} + C_{DB2}}{g_{m1}}$$

EE105 Spring 2008

Lecture 21, Slide 19

Prof. Wu, UC Berkeley

Source Follower: Input Capacitance

- Recall that the voltage gain of a source follower is $A_v = \frac{R_S}{\frac{1}{g_m} + R_S}$

Follower stage with MOSFET capacitances shown

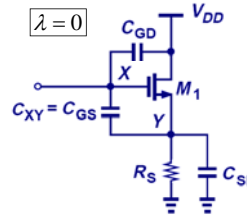

- C_{XY} can be decomposed into C_X and C_Y at the input and output nodes, respectively:

$$C_X = (1 - A_v) C_{GS} = \frac{C_{GS}}{1 + g_m R_S}$$

$$C_{in} = C_{GD} + \frac{C_{GS}}{1 + g_m R_S}$$

EE105 Spring 2008

Lecture 21, Slide 20

Prof. Wu, UC Berkeley

Example

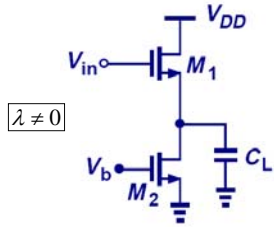

$$C_{in} = C_{GD1} + \frac{1}{1 + g_{m1}(r_{O1} \parallel r_{O2})} C_{GS1}$$

EE105 Spring 2008

Lecture 21, Slide 21

Prof. Wu, UC Berkeley

Source Follower: Output Impedance

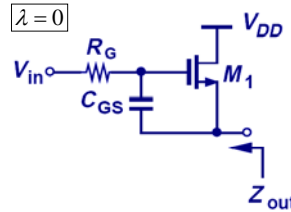

- The output impedance of a source follower can be obtained by direct AC analysis of small-signal model, similarly as for the emitter follower

$$\frac{v_X}{i_X} = \frac{j\omega R_G C_{GS} + 1}{j\omega C_{GS} + g_m}$$

EE105 Spring 2008

Lecture 21, Slide 22

Prof. Wu, UC Berkeley

Source Follower as Active Inductor

$$Z_{out} = \frac{j\omega R_G C_{GS} + 1}{j\omega C_{GS} + g_m}$$

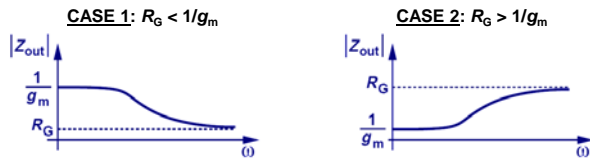

- A follower is typically used to lower the driving impedance, i.e. R_G is large compared to $1/g_m$, so that the "active inductor" characteristic on the right is usually observed.

EE105 Spring 2008

Lecture 21, Slide 23

Prof. Wu, UC Berkeley

Example

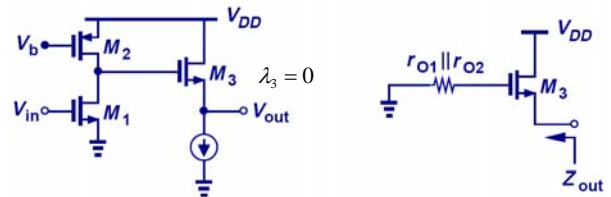

$$Z_{out} = \frac{j\omega(r_{O1} \parallel r_{O2})C_{GS3} + 1}{j\omega C_{GS3} + g_{m3}}$$

EE105 Spring 2008

Lecture 21, Slide 24

Prof. Wu, UC Berkeley

MOS Cascode Stage

- For a cascode stage, Miller multiplication is smaller than in the CS stage.

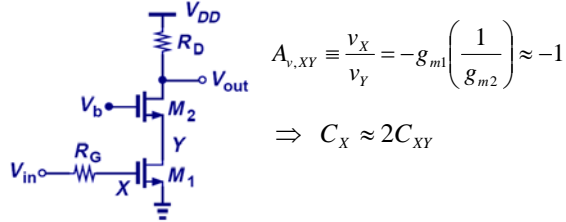

$$A_{v,XY} \equiv \frac{v_X}{v_Y} = -g_{m1} \left(\frac{1}{g_{m2}} \right) \approx -1$$

$$\Rightarrow C_X \approx 2C_{XY}$$

Cascode Stage: Pole Frequencies

$\lambda = 0$

Cascode stage with MOSFET capacitances shown
(Miller approximation applied)

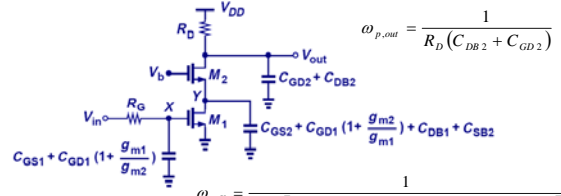

$$\omega_{p,out} = \frac{1}{R_D(C_{DB2} + C_{GD2})}$$

$$\omega_{p,Y} = \frac{1}{\frac{1}{g_{m2}} \left[C_{DB1} + C_{GS2} + \left(1 + \frac{g_{m2}}{g_{m1}} \right) C_{GD1} + C_{SB2} \right]}$$

$$\omega_{p,X} = \frac{1}{R_G \left[C_{GS1} + \left(1 + \frac{g_{m1}}{g_{m2}} \right) C_{GD1} \right]}$$

Cascode Stage: I/O Impedances

$\lambda = 0$

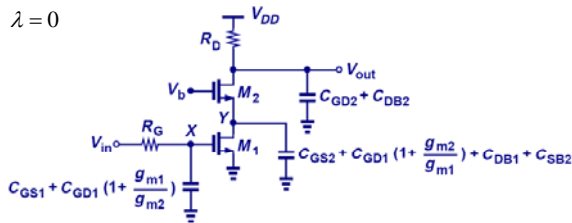

$$Z_{in} = \frac{1}{j\omega \left[C_{GS1} + \left(1 + \frac{g_{m1}}{g_{m2}} \right) C_{GD1} \right]}$$

$$Z_{out} = R_D \parallel \frac{1}{j\omega(C_{GD2} + C_{DB2})}$$