

Lecture 6

OUTLINE

- Bipolar Amplifiers
 - General considerations
 - Bias circuit and operating point analysis

Reading: Chapter 5.1-5.2

EE105 Spring 2008

Lecture 6, Slide 1

Prof. Wu, UC Berkeley

Bipolar Amplifiers

General Concepts

- Input and Output Impedances
- Biasing
- DC and Small-Signal Analysis

Operating Point Analysis

- Simple Biasing
- Emitter Degeneration
- Self-Biasing
- Biasing of PNP Devices

Amplifier Topologies

- Common-Emitter Stage
- Common-Base Stage
- Emitter Follower

EE105 Spring 2008

Lecture 6, Slide 2

Prof. Wu, UC Berkeley

Voltage Amplifier

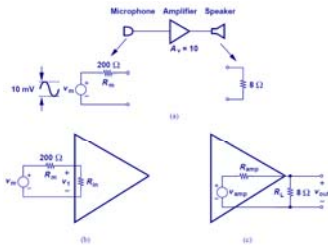

- In an ideal voltage amplifier, the input impedance is infinite and the output impedance zero.
- But in reality, input or output impedances depart from their ideal values.

EE105 Spring 2008

Lecture 6, Slide 3

Prof. Wu, UC Berkeley

Input/Output Impedances

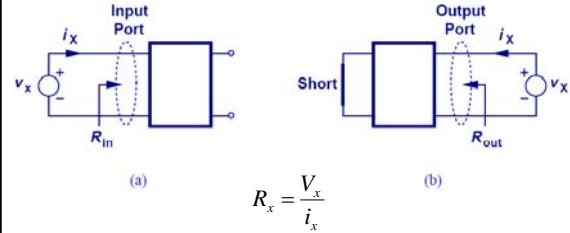

- The figure above shows the techniques of measuring input and output impedances.

EE105 Spring 2008

Lecture 6, Slide 4

Prof. Wu, UC Berkeley

Input Impedance Example I

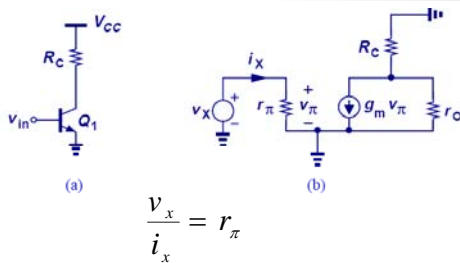

$$\frac{v_x}{i_x} = r_{\pi}$$

- When calculating input/output impedance, small-signal analysis is assumed.

EE105 Spring 2008

Lecture 6, Slide 5

Prof. Wu, UC Berkeley

Impedance at a Node

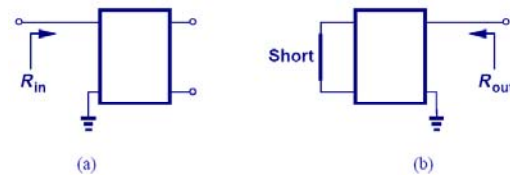

- When calculating I/O impedances at a port, we usually ground one terminal while applying the test source to the other terminal of interest.

EE105 Spring 2008

Lecture 6, Slide 6

Prof. Wu, UC Berkeley

Impedance at Collector

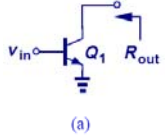
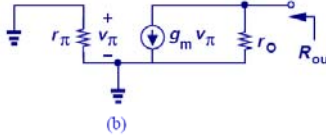



$R_{out} = r_o$

- With Early effect, the impedance seen at the collector is equal to the intrinsic output impedance of the transistor (if emitter is grounded).

EE105 Spring 2008 Lecture 6, Slide 7 Prof. Wu, UC Berkeley

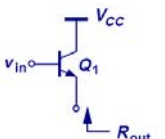
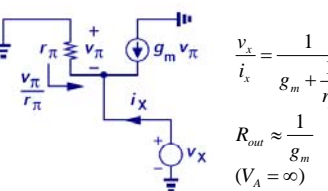
Impedance at Emitter

$$\frac{v_x}{i_x} = \frac{1}{g_m + \frac{1}{r_\pi}}$$

$$R_{out} \approx \frac{1}{g_m} \quad (V_A = \infty)$$

- The impedance seen at the emitter of a transistor is approximately equal to one over its transconductance (if the base is grounded).

EE105 Spring 2008 Lecture 6, Slide 8 Prof. Wu, UC Berkeley

Three Master Rules of Transistor Impedances

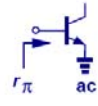
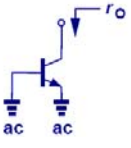
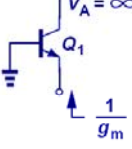
- Rule # 1: looking into the base, the impedance is r_π if emitter is (ac) grounded.
- Rule # 2: looking into the collector, the impedance is r_o if emitter is (ac) grounded.
- Rule # 3: looking into the emitter, the impedance is $1/g_m$ if base is (ac) grounded and Early effect is neglected.

EE105 Spring 2008 Lecture 6, Slide 9 Prof. Wu, UC Berkeley

Biasing of BJT

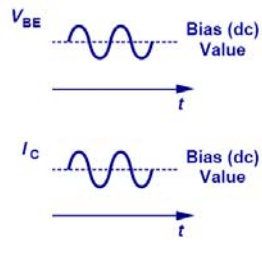

- Transistors and circuits must be biased because (1) transistors must operate in the active region, (2) their small-signal parameters depend on the bias conditions.

EE105 Spring 2008 Lecture 6, Slide 10 Prof. Wu, UC Berkeley

DC Analysis vs. Small-Signal Analysis

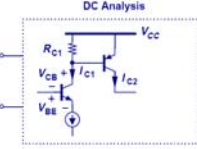
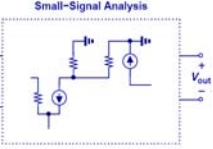
- First, DC analysis is performed to determine operating point and obtain small-signal parameters.
- Second, sources are set to zero and small-signal model is used.

EE105 Spring 2008 Lecture 6, Slide 11 Prof. Wu, UC Berkeley

Notation Simplification

- Hereafter, the battery that supplies power to the circuit is replaced by a horizontal bar labeled V_{CC} , and input signal is simplified as one node called V_{in} .

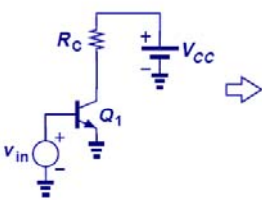
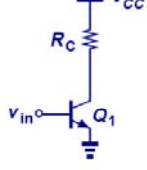
EE105 Spring 2008 Lecture 6, Slide 12 Prof. Wu, UC Berkeley

Example of Bad Biasing

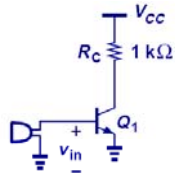

- The microphone is connected to the amplifier in an attempt to amplify the small output signal of the microphone.
- Unfortunately, there's no DC bias current running through the transistor to set the transconductance.

EE105 Spring 2008 Lecture 6, Slide 13 Prof. Wu, UC Berkeley

Another Example of Bad Biasing

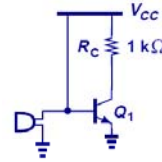

- The base of the amplifier is connected to V_{CC} , trying to establish a DC bias.
- Unfortunately, the output signal produced by the microphone is shorted to the power supply.

EE105 Spring 2008 Lecture 6, Slide 14 Prof. Wu, UC Berkeley

Biasing with Base Resistor

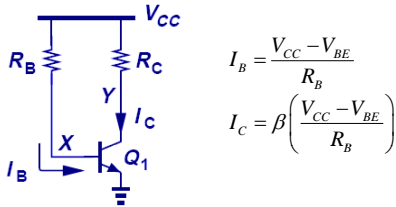

- Assuming a constant value for V_{BE} , one can solve for both I_B and I_C and determine the terminal voltages of the transistor.
- However, bias point is sensitive to β variations.

EE105 Spring 2008 Lecture 6, Slide 15 Prof. Wu, UC Berkeley

Improved Biasing: Resistive Divider

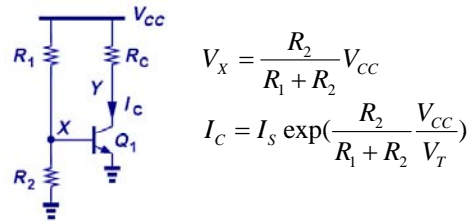

- Using resistor divider to set V_{BE} , it is possible to produce an I_C that is relatively independent of β if base current is small.

EE105 Spring 2008 Lecture 6, Slide 16 Prof. Wu, UC Berkeley

Accounting for Base Current

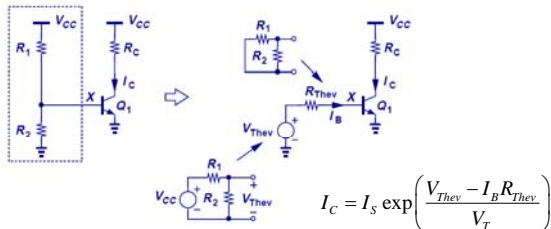

- With proper ratio of R_1 and R_2 , I_C can be insensitive to β ; however, its exponential dependence on resistor deviations makes it less useful.

EE105 Spring 2008 Lecture 6, Slide 17 Prof. Wu, UC Berkeley

Emitter Degeneration Biasing

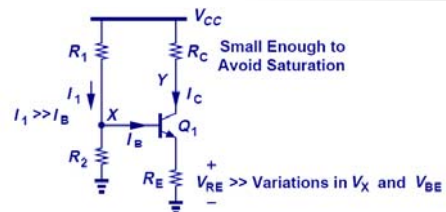

- The presence of R_E helps to absorb the error in V_X so V_{BE} stays relatively constant.
- This bias technique is less sensitive to β ($I_1 \gg I_B$) and V_{BE} variations.

EE105 Spring 2008 Lecture 6, Slide 18 Prof. Wu, UC Berkeley

Design Procedure

- Choose an I_C to provide the necessary small signal parameters, g_m, r_{π} , etc.
- Considering the variations of R_1, R_2 , and V_{BE} , choose a value for V_{RE} .
- With V_{RE} chosen, and V_{BE} calculated, V_x can be determined.
- Select R_1 and R_2 to provide V_x

EE105 Spring 2008

Lecture 6, Slide 19

Prof. Wu, UC Berkeley

Self-Biasing Technique

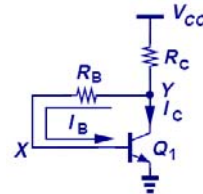

- This bias technique utilizes the collector voltage to provide the necessary V_x and I_B .
- One important characteristic of this technique is that collector has a higher potential than the base, thus guaranteeing active operation of the transistor.

EE105 Spring 2008

Lecture 6, Slide 20

Prof. Wu, UC Berkeley

Self-Biasing Design Guidelines

$$(1) R_C \gg \frac{R_B}{\beta}$$

$$(2) \Delta V_{BE} \ll V_{CC} - V_{BE}$$

- (1) provides insensitivity to β .
- (2) provides insensitivity to variation in V_{BE} .

EE105 Spring 2008

Lecture 6, Slide 21

Prof. Wu, UC Berkeley

Summary of Biasing Techniques

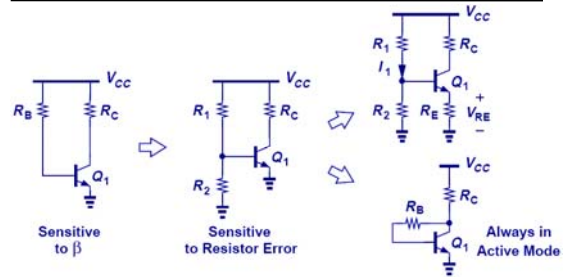

EE105 Spring 2008

Lecture 6, Slide 22

Prof. Wu, UC Berkeley

PNP Biasing Techniques

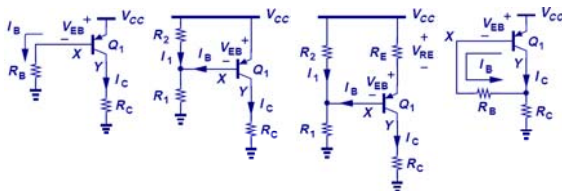

- Same principles that apply to NPN biasing also apply to PNP biasing with only polarity modifications.

EE105 Spring 2008

Lecture 6, Slide 23

Prof. Wu, UC Berkeley