

Lecture 9

OUTLINE

- BJT Amplifiers (2)
 - Common-base topology
 - CB core
 - CB stage with source resistance
 - Impact of base resistance

Reading: Chapter 5.3.2

EE105 Spring 2008

Lecture 9, Slide 1

Prof. Wu, UC Berkeley

Common Base (CB) Amplifier

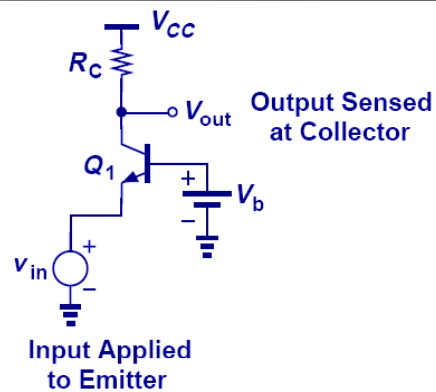

- In common base topology, where the base terminal is biased with a fixed voltage, emitter is fed with a signal, and collector is the output.

EE105 Spring 2008

Lecture 9, Slide 2

Prof. Wu, UC Berkeley

CB Core

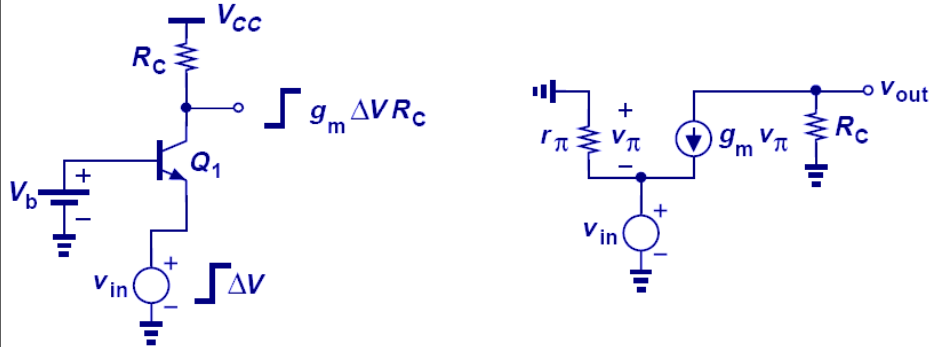

- The voltage gain of CB stage is $g_m R_C$, which is identical to that of CE stage in magnitude and opposite in phase.

EE105 Spring 2008

Lecture 9, Slide 3

Prof. Wu, UC Berkeley

Tradeoff between Gain and Headroom

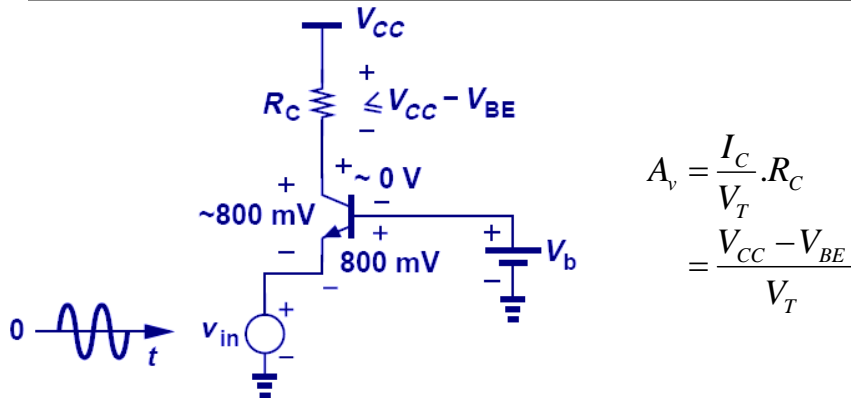

$$A_v = \frac{I_C}{V_T} \cdot R_C = \frac{V_{CC} - V_{BE}}{V_T}$$

- To maintain the transistor out of saturation, the maximum voltage drop across R_C cannot exceed $V_{CC} - V_{BE}$.

EE105 Spring 2008

Lecture 9, Slide 4

Prof. Wu, UC Berkeley

Simple CB Stage Example

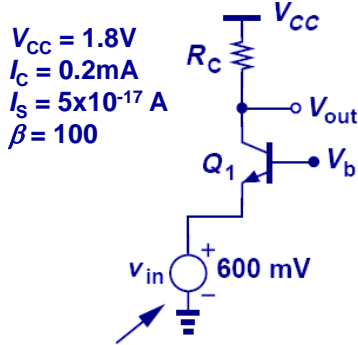

Thermometer

$$A_v = g_m R_C = \frac{1}{130} \cdot 2230 = 17.2$$

$$V_b = V_{BE} + 0.6 = V_T \ln\left(\frac{I_C}{I_S}\right) = 1.354V$$

EE105 Spring 2008

Lecture 9, Slide 5

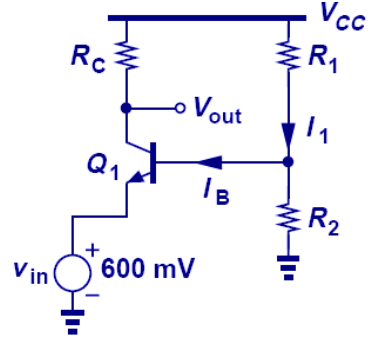

$$V_b = 1.354V \cong \frac{R_2}{R_1 + R_2} V_{CC} \text{ if } I_1 \gg I_B$$

$$\text{Choose } I_1 \approx 10I_B = 20\mu A \cong \frac{V_{CC}}{R_1 + R_2}$$

$$\Rightarrow R_1 = 22.3k\Omega, R_2 = 67.7k\Omega$$

Prof. Wu, UC Berkeley

Input Impedance of CB

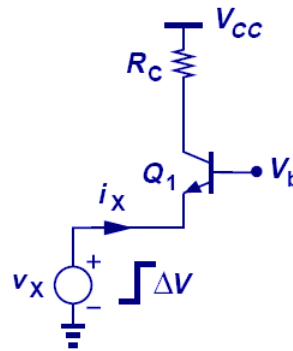
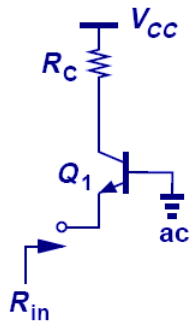

$$R_{in} = \frac{1}{g_m}$$

- The input impedance of CB stage is much smaller than that of the CE stage.

EE105 Spring 2008

Lecture 9, Slide 6

Prof. Wu, UC Berkeley

Practical Application of CB Stage

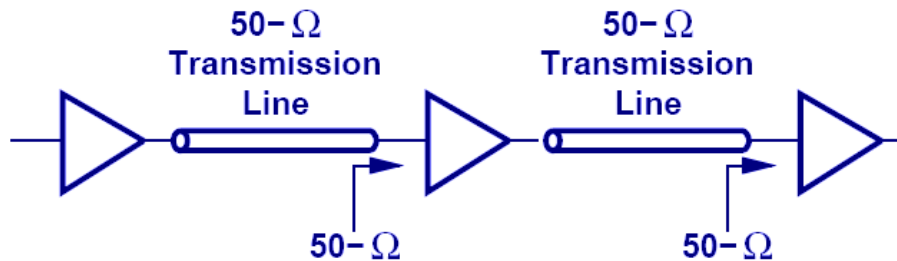

- To avoid “reflections”, need impedance matching.
- CB stage’s low input impedance can be used to create a match with 50 Ω .

EE105 Spring 2008

Lecture 9, Slide 7

Prof. Wu, UC Berkeley

Output Impedance of CB Stage

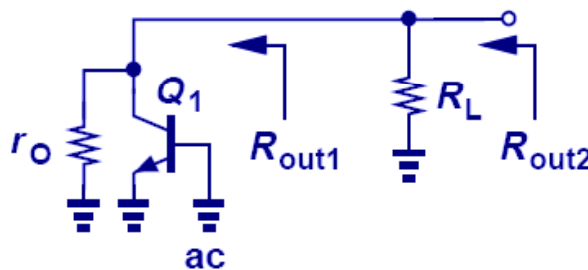

$$R_{out} = r_O \parallel R_L$$

- The output impedance of CB stage is similar to that of CE stage.

EE105 Spring 2008

Lecture 9, Slide 8

Prof. Wu, UC Berkeley

CB Stage with Source Resistance

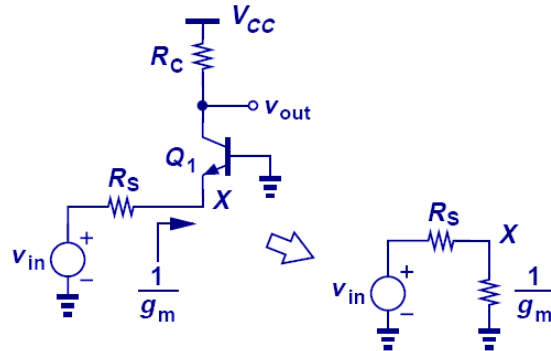

$$A_v = \frac{R_C}{\frac{1}{g_m} + R_S}$$

- With an inclusion of a source resistor, the input signal is attenuated before it reaches the emitter of the amplifier; therefore, we see a lower voltage gain.
- This is similar to CE stage emitter degeneration; only the phase is reversed.

EE105 Spring 2008

Lecture 9, Slide 9

Prof. Wu, UC Berkeley

Practical Example of CB Stage

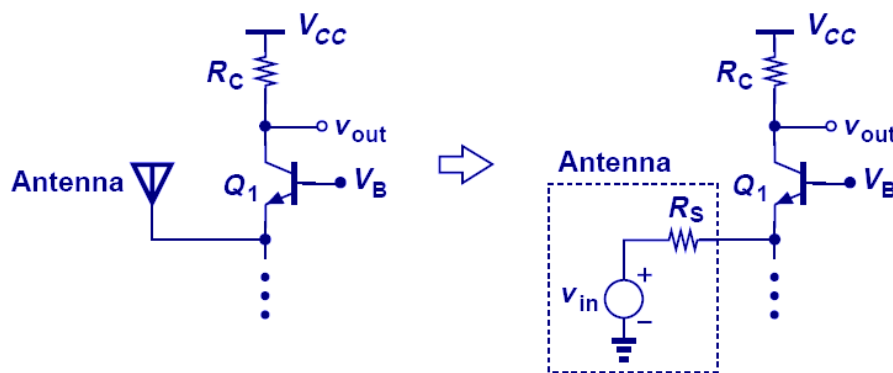

- An antenna usually has low output impedance; therefore, a correspondingly low input impedance is required for the following stage.

EE105 Spring 2008

Lecture 9, Slide 10

Prof. Wu, UC Berkeley

Realistic Output Impedance of CB Stage

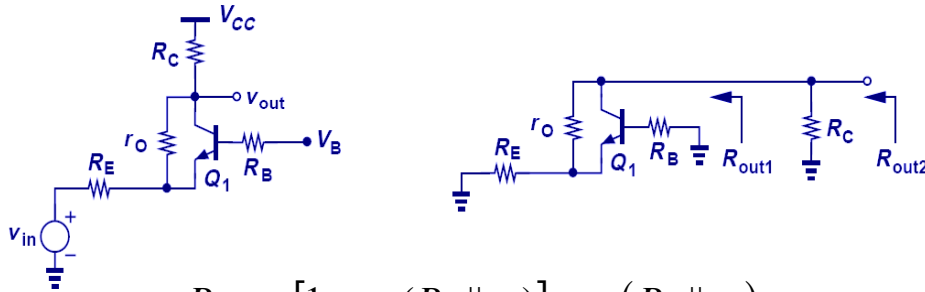

$$R_{out1} = [1 + g_m (R_E \parallel r_\pi)] r_o + (R_E \parallel r_\pi)$$

$$R_{out} = R_C \parallel R_{out1}$$

- The output impedance of CB stage is equal to R_C in parallel with the impedance looking down into the collector.

EE105 Spring 2008

Lecture 9, Slide 11

Prof. Wu, UC Berkeley

Output Impedance of CE and CB Stages

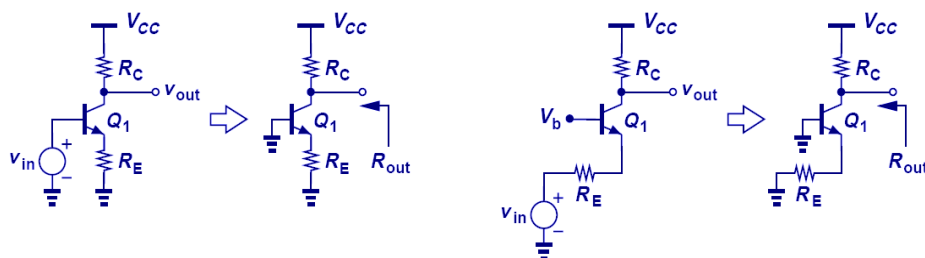

- The output impedances of CE, CB stages are the same if both circuits are under the same condition. This is because when calculating output impedance, the input port is grounded, which renders the same circuit for both CE and CB stages.

EE105 Spring 2008

Lecture 9, Slide 12

Prof. Wu, UC Berkeley

CB with Base Resistance

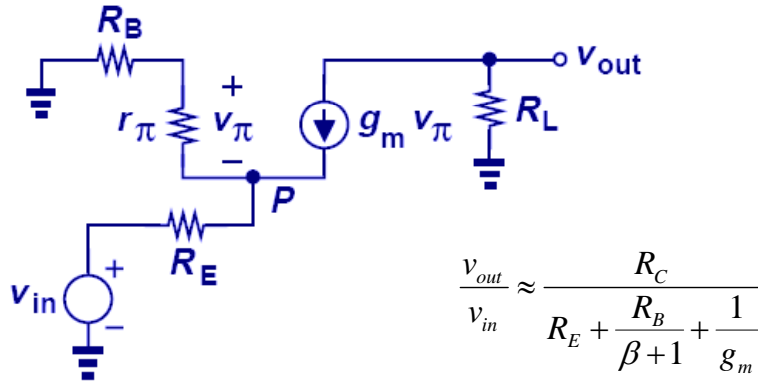

- With an addition of base resistance, the voltage gain degrades.

EE105 Spring 2008

Lecture 9, Slide 13

Prof. Wu, UC Berkeley

Comparison of CE and CB Stages with Base Resistance

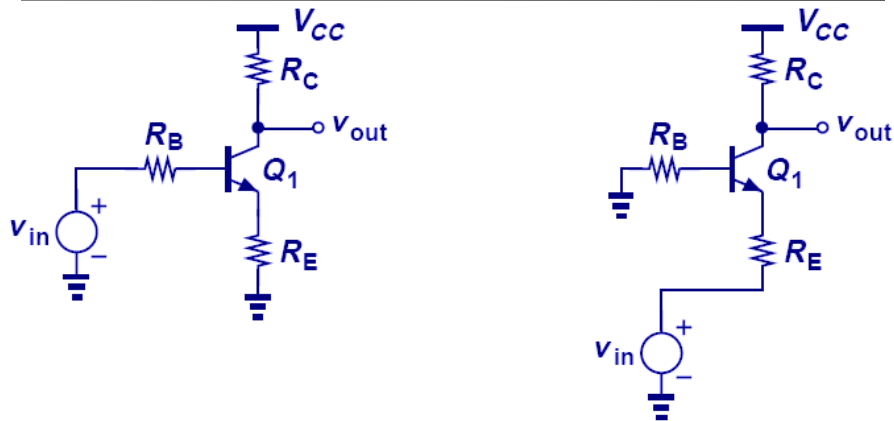

- The voltage gain of CB amplifier with base resistance is exactly the same as that of CE stage with base resistance and emitter degeneration, except for a negative sign.

EE105 Spring 2008

Lecture 9, Slide 14

Prof. Wu, UC Berkeley

Input Impedance of CB Stage with Base Resistance

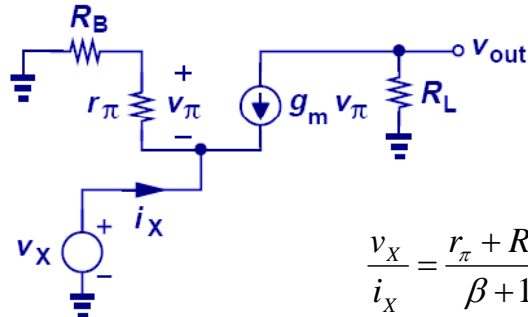

$$\frac{v_X}{i_X} = \frac{r_\pi + R_B}{\beta + 1} \approx \frac{1}{g_m} + \frac{R_B}{\beta + 1}$$

- The input impedance of CB with base resistance is equal to $1/g_m$ plus R_B divided by $(\beta+1)$. This is in contrast to degenerated CE stage, in which the resistance in series with the emitter is multiplied by $(\beta+1)$ when seen from the base.

EE105 Spring 2008

Lecture 9, Slide 15

Prof. Wu, UC Berkeley

Input Impedance Seen at Emitter and Base

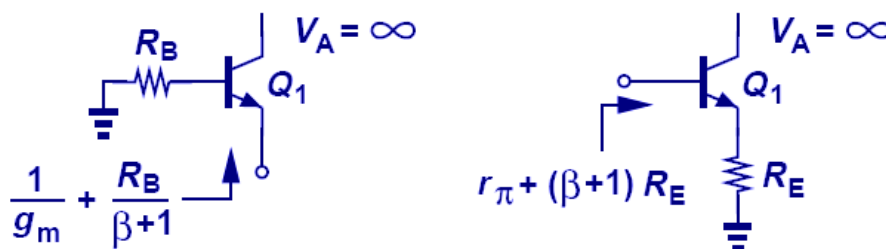

EE105 Spring 2008

Lecture 9, Slide 16

Prof. Wu, UC Berkeley

Input Impedance Example

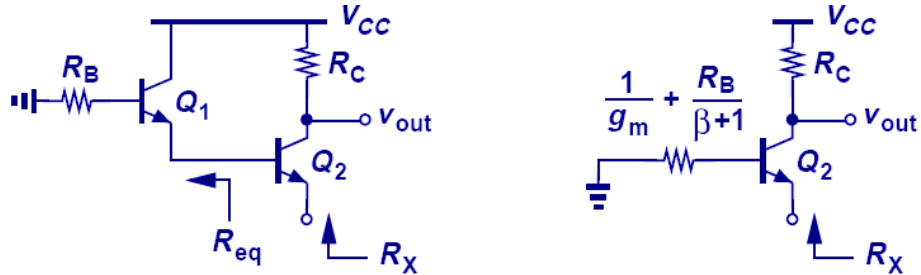

$$R_X = \frac{1}{g_{m2}} + \frac{1}{\beta+1} \left(\frac{1}{g_{m1}} + \frac{R_B}{\beta+1} \right)$$

- To find the R_X , we have to first find R_{eq} , treat it as the base resistance of Q_2 and divide it by $(\beta+1)$.

EE105 Spring 2008

Lecture 9, Slide 17

Prof. Wu, UC Berkeley

Bad Bias Technique for CB Stage

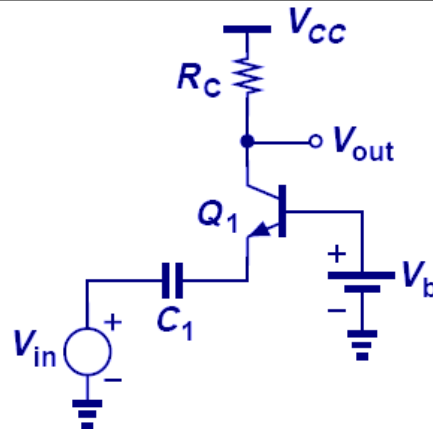

- Unfortunately, no emitter current can flow.

EE105 Spring 2008

Lecture 9, Slide 18

Prof. Wu, UC Berkeley

Still No Good

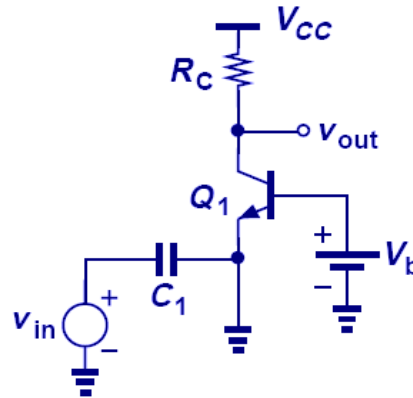

- The input signal is shorted to ground. The circuit still does not amplify.

EE105 Spring 2008

Lecture 9, Slide 19

Prof. Wu, UC Berkeley

Proper Biasing for CB Stage

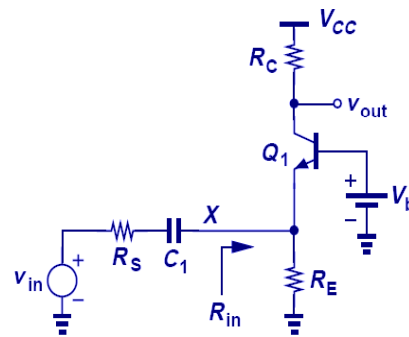
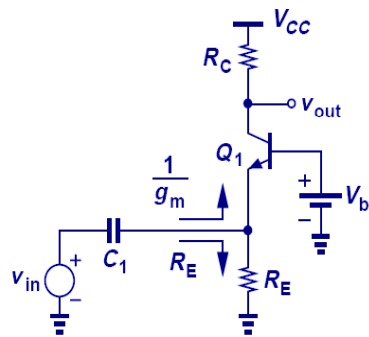

$$R_{in} = \frac{1}{g_m} \parallel R_E = \frac{R_E}{1 + g_m R_E}$$

$$\frac{v_X}{v_{in}} = \frac{R_{in}}{R_{in} + R_S} = \frac{1}{1 + (1 + g_m R_E)(R_S / R_E)}$$

$$\frac{v_{out}}{v_{in}} = \frac{v_{out}}{v_X} \frac{v_X}{v_{in}} = \frac{1}{1 + (1 + g_m R_E) \frac{R_S}{R_E}} g_m R_C$$

EE105 Spring 2008

Lecture 9, Slide 20

Prof. Wu, UC Berkeley

Reduction of Input Impedance Due to R_E

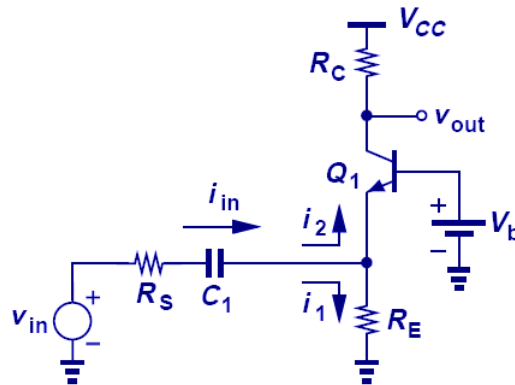

- The reduction of input impedance due to R_E is bad because it shunts part of the input current to ground instead of to Q_1 (and R_C).

EE105 Spring 2008

Lecture 9, Slide 21

Prof. Wu, UC Berkeley

Creation of V_b

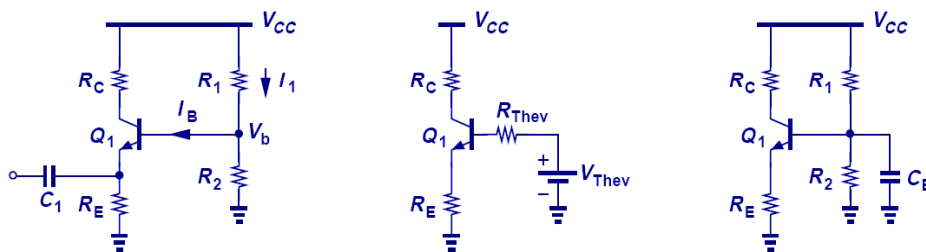

- Resistive divider lowers the gain.
- To remedy this problem, a capacitor is inserted from base to ground to short out the resistor divider at the frequency of interest.

EE105 Spring 2008

Lecture 9, Slide 22

Prof. Wu, UC Berkeley

Example of CB Stage with Bias

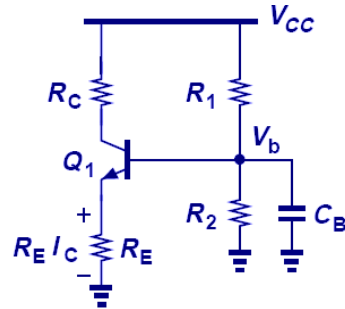

- For the circuit shown above, $R_E \gg 1/g_m$.
- R_1 and R_2 are chosen so that V_b is at the appropriate value and the current that flows thru the divider is much larger than the base current.
- Capacitors are chosen to be small compared to $1/g_m$ at the required frequency.