

1. Modular Circuits

In this problem, we will explore the design of circuits that perform a set of (arbitrary) mathematical operations. (Note that the so-called analog signal processing – where these kinds of mathematical operations are performed on continuously-valued voltages by analog circuits – is extremely common in real-world applications; without this capability, essentially none of our radios or sensors would actually work.) Specifically, let's assume that we want to implement the block diagram shown below:

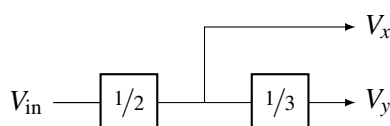

In other words, we want to implement a circuit with two outputs V_x and V_y , where $V_x = \frac{1}{2}V_{in}$ and $V_y = \frac{1}{3}V_x$.

- Design two voltage divider circuits that each independently would implement the two multiplications shown in the block diagram above (i.e., multiply by $1/2$ and multiply by $1/3$). Note that you do not need to include the input voltage sources in your design – you can simply define the input to each block as being at the appropriate potential (e.g., V_{in} or V_x).
- Assuming that V_{in} is created by an ideal voltage source, implement the original block diagram as a circuit by directly replacing each block with the designs you came up with in part (a).
- For the circuit from part (b), do you get the desired relationship between V_y and V_x ? How about between V_x and V_{in} ? Be sure to explain why or why not each block retains its desired functionality.
- Now let's assume that we have discovered compose-able circuits that implement mathematical operations. In particular, we have these blocks that implement:
 - $V_o = 5V_i$
 - $V_o = -2V_i$
 - $V_o = V_{i_1} + V_{i_2}$

Using just these blocks, draw the block diagram that implements:

- $V_o = -12V_{in_1}$
- [PRACTICE]** $V_o = -10V_{in_1} - 2V_{in_2}$
- [PRACTICE]** $V_o = -V_{in_1} + V_{in_2}$

2. Op-Amps As Comparators

For each of the circuits shown below, plot V_{out} for V_{in} ranging from $-10V$ to $10V$ for part (a) and from $0V$ to $10V$ for part (b). Let $A = 100$ for your plots. Note that in real op amps, A is typically much higher (i.e. $10^4 - 10^7$).

-

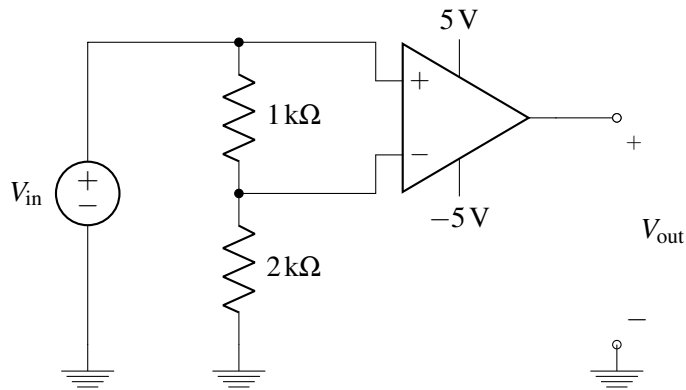

(b) [PRACTICE]

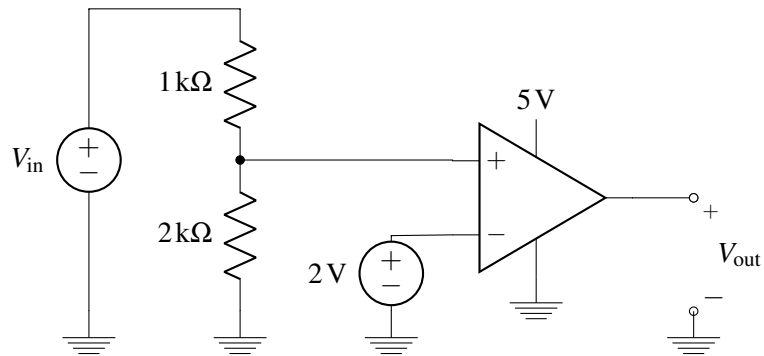

3. Current Sources And Capacitors

For the circuits given below, give an expression for $v_{out}(t)$ in terms of I_s , C_1 , C_2 , C_3 , and t . Assume that all capacitors are initially uncharged, i.e. the initial voltage across each capacitor is 0V.

(a)

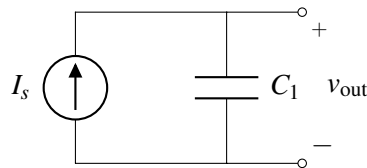

(b)

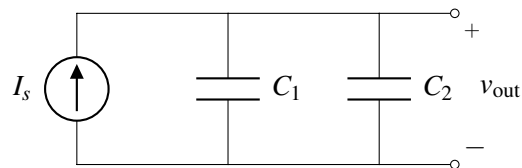

4. Bio-Molecule Detector [PRACTICE]

We've already seen how to build a bio-molecule detector where bio-molecules change the resistance between two electrodes. In this problem, we will explore a different scheme, where bio-molecules change the capacitance between two electrodes.

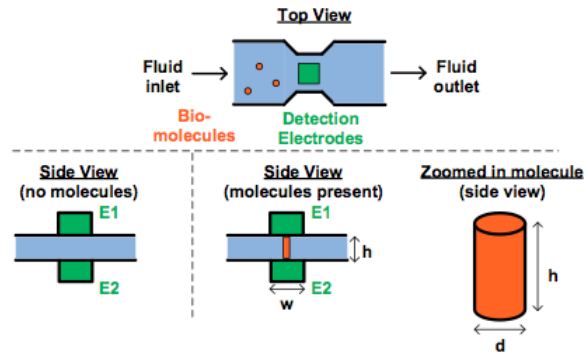

Figure 1: Bio-molecule detector.

As shown in Figure 1, the detector works by flowing a liquid that may or may not contain the biomolecules through a region in the device that has electrodes on the top and bottom of the liquid channel. The electrodes (E1/E2 in Figure 1) are chemically “functionalized” (using e.g. some appropriately designed antibodies), so that if the specific bio-molecule of interest is present in the fluid sample, one or more of the molecules will get physically trapped between the two electrodes (bottom right of Figure 1). After all of the fluid has been cleared out of the device (i.e., so that if there are bio-molecules present, there is only air in between the two electrodes E1/E2), we can then figure out whether or not one or more bio-molecules were trapped by measuring the capacitance between the two electrodes.

- If no bio-molecules are present, what should the capacitance between E1/E2 be? Assume that the electrodes are $10\mu\text{m}$ on each side and that the electrodes are 100nm apart. Leave your answer in terms of ϵ_0 .
- As shown in Figure 1, if each bio-molecule is a cylinder with diameter $d = 2\mu\text{m}$, height $h = 100\text{nm}$, and permittivity $\epsilon_b = 4\epsilon_0$, what would the capacitance between E1 and E2 be if only a single bio-molecule is trapped? Note that you can assume that the trapped molecule is exactly vertically oriented when it is trapped – i.e., the top and bottom faces of the molecule are both aligned with surfaces of the electrodes.
- Using the same numbers for d , h , and ϵ_b as in part (b), as a function of the number of trapped bio-molecules $N_{\text{molecules}}$, what is the capacitance between E1 and E2? (Note that you can assume that $N_{\text{molecules}}$ is small enough that all of the molecules fit within the electrode area and that all of the molecules are still trapped in exactly vertical orientation.)