

16.1 Introduction to Capacitive Touchscreen

We've seen how a resistive touchscreen works by using the concept of voltage dividers. Essentially, for a resistive touchscreen, we map the value of analog voltage to the position touched. Another way to design a touchscreen is to break the screen down into a bunch of pixels. At each one of the pixels, we can detect whether the finger is touching it or not. This allows the touchscreen to sense multiple touch points at a time. In order to do this efficiently, we need a new element: **capacitors**. One of the nice features of the capacitive touchscreen is that you don't have to bend anything like we did for the resistive touchscreen — the presence or absence of the finger can modify the capacitance directly!

16.2 Capacitor

A **capacitor** is a circuit element that stores charge. Capacitors have an associated quantity called **capacitance**, which represents how much charge can be stored for a given amount of voltage. We usually denote capacitance with C . Let's represent voltage across the capacitor as V_C and the charge stored on the capacitor as Q . This relation is often written as:

$$Q = CV_C. \tag{1}$$

When we draw circuits, the symbol for a capacitor is:

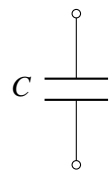

The unit of capacitance is **Farad (F)**. A capacitor with capacitance of $1F$ stores $1C$ of charge across it when it has $1V$ of potential energy across its electrodes.

Let's examine the defining relationship of a capacitor:

$$Q = CV_C. \tag{2}$$

Differentiating both sides with respect to t and assuming a constant capacitance, we have

$$\frac{dQ}{dt} = \frac{dCV_C}{dt} = C \frac{dV_C}{dt}. \tag{3}$$

However, we know that current $I = \frac{dQ}{dt}$. Hence,

$$I = C \frac{dV_C}{dt}. \quad (4)$$

Thus, the current through a capacitor is the product of the capacitance and the rate of change of the voltage across the capacitor. This yields the following graph, with slope equal to C :

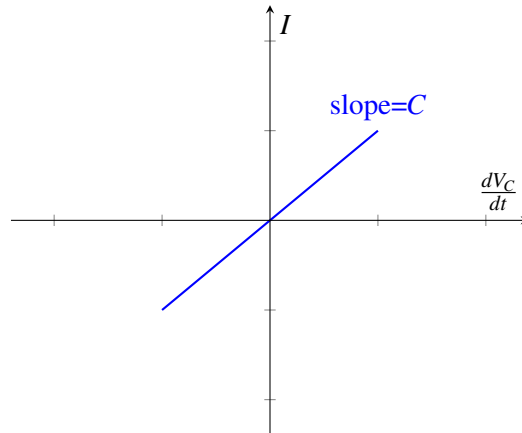

An important implication of this is that **current is only flowing through the capacitor if the voltage across the capacitor is changing with time**. If the voltage is no longer changing, then the current through the capacitor will equal 0.

How can we solve for the voltage across the capacitor? In other words, how do we find $V_C(t)$? There are many ways to solve Equation 4, but we will use separation of variables and then integrate both sides, shown below. Note that it's okay if you haven't seen this technique before, it is not required for this class.

$$I = C \frac{dV_C}{dt}. \quad (5)$$

$$I dt = C dV_C \quad (6)$$

$$\int_0^t I dt = \int_0^{V_C} C dV_C \quad (7)$$

To integrate the left-hand side, we assume that the current I is constant over time. When we integrate the right-hand side, we must account for the initial voltage across the capacitor, $V_C(0)$.

$$It = C(V_C(t) - V_C(0)) \quad (8)$$

$$V_C(t) = \frac{I}{C}t + V_C(0) \quad (9)$$

This yields the following graph, with slope equal to $\frac{I}{C}$. Although Eq. 4 is fully general, Eq. 9 is only valid when the current is constant over time.

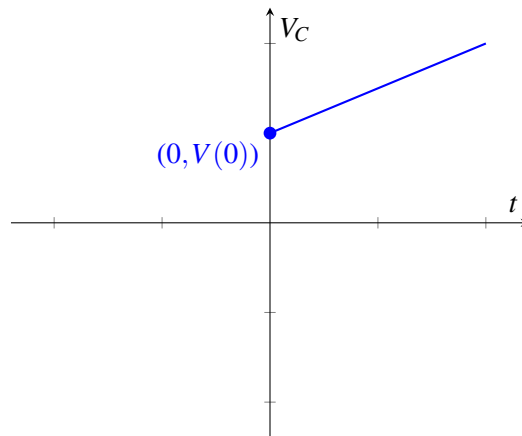

Let's see what happens when we connect a capacitor with a voltage source.

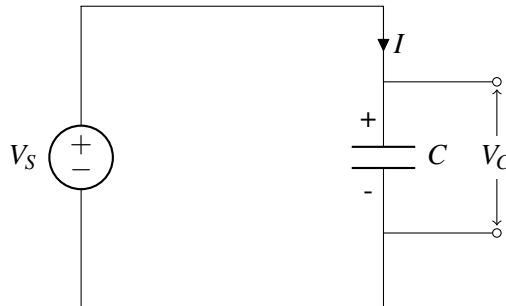

We know that initially, charges are going to build up on the two plates — positive charges on the top plate and negative charges on the bottom plate. Once enough charge has been stored, the voltage across the capacitor becomes $V_C = V_S$; because the voltage can no longer increase past this point, the current I flowing through the circuit becomes zero.

16.3 Capacitor Equivalence

Note that when we initially talked about equivalence it was in terms of $I - V$. But what about for capacitors? Now we will specify equivalence in terms of $I - \frac{dV}{dt}$. That means we need to apply I_{test} and measure $\frac{dV_{test}}{dt}$ or apply $\frac{dV_{test}}{dt}$ and measure I_{test} . Then we can calculate the equivalent capacitance:

$$C_{eq} = \frac{I_{test}}{\frac{dV_{test}}{dt}}$$

Just like resistors, we can connect capacitors in series and in parallel. We'll first focus on capacitor-only circuits, which means that we don't need to find Thevenin/Norton equivalent circuits; it will just be a capacitor.

16.3.1 Capacitors in parallel

Given the following circuit:

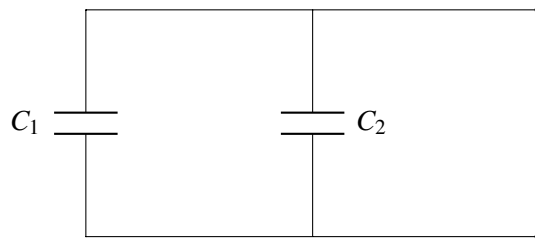

What is the equivalent capacitance? By analogy with our resistor case, we will try and apply a test voltage to this circuit:

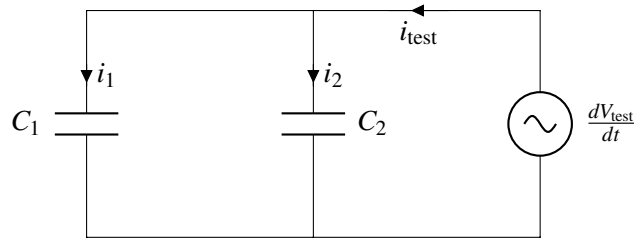

$$i_1 = C_1 \frac{dV_{test}}{dt}$$

$$i_2 = C_2 \frac{dV_{test}}{dt}$$

$$i_T = i_1 + i_2 = (C_1 + C_2) \frac{dV_{test}}{dt}$$

$$\therefore C_{eq} = C_1 + C_2$$

We can thus reduce our original circuit to:

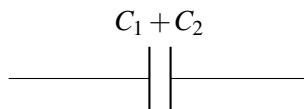

We find that in general, the equivalent capacitance of capacitors in parallel is the sum of their capacitance

16.3.2 Capacitors in series

Given the circuit:



What is the equivalent capacitance here? By symmetry with the resistor case, let's apply a test current and measure the resulting voltage:

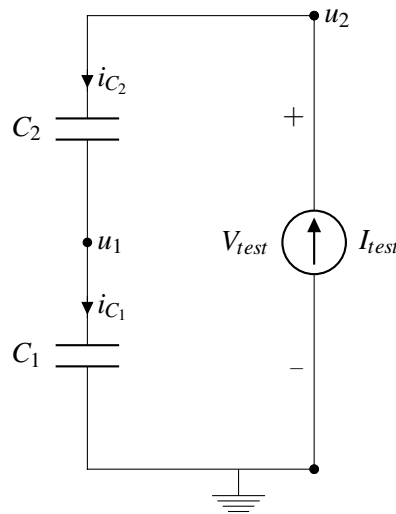

From KCL, we know that all of the currents are equal.

$$i_{C_1} = i_{C_2} = I_{test}$$

For each capacitor, we plug in our $I - \frac{dV}{dt}$ relationship:

$$i_{C_1} = I_{test} = C_1 \frac{du_1}{dt}$$

$$i_{C_2} = I_{test} = C_2 \frac{d(u_2 - u_1)}{dt} = C_2 \left(\frac{du_2}{dt} - \frac{du_1}{dt} \right)$$

Next, we eliminate u_1 from the equations above and rearrange.

$$\frac{du_1}{dt} = \frac{I_{test}}{C_1} \Rightarrow I_{test} = C_2 \frac{du_2}{dt} - \frac{C_2}{C_1} I_{test}$$

$$I_{test} = \frac{C_2}{1 + \frac{C_2}{C_1}} \frac{du_2}{dt}$$

Finally, we plug in that $u_2 = V_{test}$ and solve for the equivalent capacitance with $C_{eq} = I_{test} / \frac{dV_{test}}{dt}$

$$I_{test} = \frac{C_2}{1 + \frac{C_2}{C_1}} \frac{dV_{test}}{dt}$$

$$\Rightarrow C_{eq} = \frac{C_2}{1 + \frac{C_2}{C_1}} = \frac{C_1 C_2}{C_1 + C_2}$$

Note that this is the same as saying $C_{eq} = C_1 \parallel C_2$. Remember that the \parallel operator is mathematical notation; in this case, the capacitors are actually in series, but *mathematically* their equivalent circuit is found via the “parallel resistor” operation.

We can thus reduce our original circuit to:

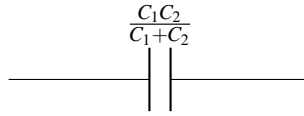

16.4 Capacitor Physics

Now that we know the properties of capacitors, let's take a look at the underlying physics. This will be useful when we want to build models for physical structures, such as our capacitive touchscreen. Remember that the physics we teach in this course is not designed to be exact or fully detailed, but is close enough to get us the understanding we need to create circuit models from physical structures.

What is the physical structure of a capacitor? Any two pieces of conductive material, typically metal, that are separated by some other material that is not in general conductive (aka an insulator), forms a capacitor.

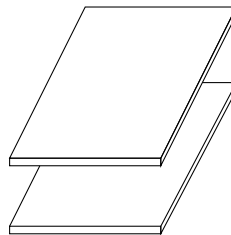

Note: What does this mean about **you** in the case of a capacitive touch screen? You're a conductor!

If there is voltage across the two pieces of conductors, charges will build up on the surface of the capacitor. As depicted below, when we apply voltage V across the two plates, positive charges build up on the (top) surface of the plate connected to the positive terminal and negative charges build up on the (bottom) surface of the plate connected to the negative terminal.

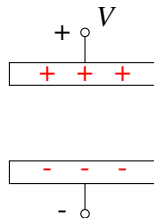

Let's try to get some intuition on capacitors by drawing an analogy between capacitors and water buckets — simply put, we can think of a capacitor as a bucket. The more water (charge) you put in the bucket, the higher the water level (voltage) would be. The water level in the bucket is determined by its dimensions. Similarly, the capacitance is set by the dimensions of the conductors and some properties of the material separating them. Please note that the water analogy is imperfect for many cases in electrical engineering- be careful not to try and extend or use it arbitrarily.

In particular, the capacitance of a capacitor is:

$$C = \epsilon \frac{A}{d} \tag{10}$$

where A is the area of the surface of the plates facing each other, d is the separation between the two plates (illustrated below), and ϵ is the "permittivity" of the material between the plates. We can deduce that ϵ has unit F/m . For example, if the material between the capacitors is air (vacuum), then $\epsilon = 8.85 \times 10^{-12} F/m$.

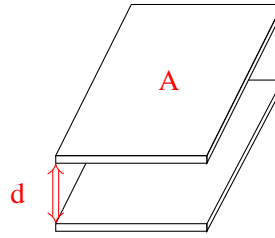

When a capacitor is charged, there is voltage across it. What does this mean? This means that there is energy stored in the capacitor. Why is there energy stored? Recall that like charges repel each other. So for example if we take a positive charge and move it closer to another positive charge, we need to exert force and thus supply energy to do so. Let's now ask the question: when the capacitor is fully charged, how much energy is stored in it? We know from previous lectures that the energy required to store an additional dq amount of charge when the voltage across the capacitor is V_C is

$$dE = V_C dq. \tag{11}$$

We also know that $dq = C dV_C$. With this in mind, we have

$$dE = V_C (C dV_C) = C V_C dV_C. \tag{12}$$

Integrating both sides, we have

$$\int_0^E dE = \int_0^V C V_C dV_C = C \int_0^V V_C dV_C \tag{13}$$

$$E = \frac{1}{2} C V^2. \tag{14}$$

Hence, the energy stored in the capacitor after it's fully charged is $\frac{1}{2} C V^2$ where V is the voltage applied across the capacitor. The charges across the capacitor cannot just disappear for no reason, and therefore the energy continues to be stored - that means we can use this element as a tool to design circuits for measuring stored charge/energy.

Let's return to our capacitor equivalence models and try to gain some more physical intuition.

Physical Intuition of Parallel Capacitors:

Suppose we combine two capacitors in parallel as follows

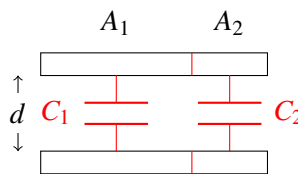

If we look at the combined capacitor above, its capacitance is equal to

$$C_{eq} = \epsilon \frac{A_1 + A_2}{d}, \quad (15)$$

which is equal to the sum of the capacitance of the two capacitors

$$C_{eq} = \epsilon \frac{A_1 + A_2}{d} = \epsilon \frac{A_1}{d} + \epsilon \frac{A_2}{d} = C_1 + C_2, \quad (16)$$

This matches the equivalence equation for parallel capacitors! In other words, connecting capacitors in parallel is analogous to summing the surface area of the two plates.

Physical Intuition of Series Capacitors:

If we take the following capacitor and draw a horizontal line in between, then it acts the same as two capacitors connected in series

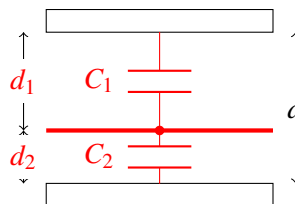

Assume that the surface area is A . Intuitively, we know that the equivalent capacitance should be smaller than both C_1 and C_2 since the plates are farther from each other. We know that $C_1 = \epsilon \frac{A}{d_1}$ and $C_2 = \epsilon \frac{A}{d_2}$. Let the capacitance of the combined capacitor be C_{eq} . It satisfies

$$\frac{1}{C_{eq}} = \frac{1}{\epsilon} \frac{d_1 + d_2}{A} = \frac{1}{\epsilon} \frac{d_1}{A} + \frac{1}{\epsilon} \frac{d_2}{A} = \frac{1}{C_1} + \frac{1}{C_2}. \quad (17)$$

Hence, the equivalent capacitance is equal to

$$C_{eq} = \frac{1}{\frac{1}{C_1} + \frac{1}{C_2}} = \frac{C_1 C_2}{C_1 + C_2}. \quad (18)$$

Notice that the examples above keep one physical dimension constant between the capacitors. This is not really necessary to arrive at these expressions for series and parallel capacitors. The expressions for equivalent capacitance that we formally derived in Section 16.3 work for capacitors of arbitrary shape/values.

16.5 Practice Problems

These practice problems are also available in an interactive form on the course website.

1. Given a parallel plate capacitor, you can increase the effective capacitance in the following way(s):
 - (a) Increasing the overlapping area of the two plates

- (b) Decreasing the distance between the two plates
 - (c) Using an insulator with a higher permittivity
 - (d) All of the above
2. True or False: Capacitors in series have an equivalent capacitance that is smaller than any of the individual capacitances (assuming that all capacitances are positive capacitance).
 3. True or False: Capacitors in parallel have an equivalent capacitance that is smaller than any of the individual capacitances (assuming that all capacitances are positive).
 4. True or False: Given the current through a capacitor, is it possible to determine the voltage across it at time t ?
 5. Consider the circuit below. Find an expression for $v_{\text{out}}(t)$ in terms of I_s , C_1 , C_2 , C_3 , C_4 , and t . Assume that all capacitors are initially uncharged.

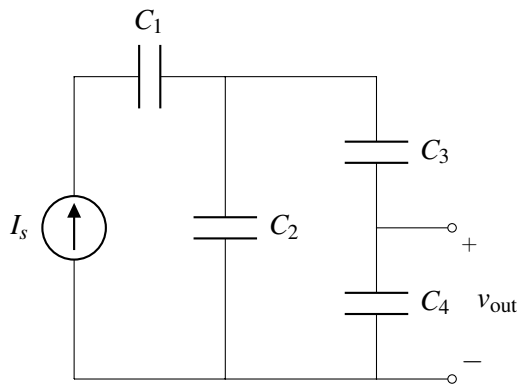

6. Find the equivalent capacitance between the terminals a and b in terms of C .

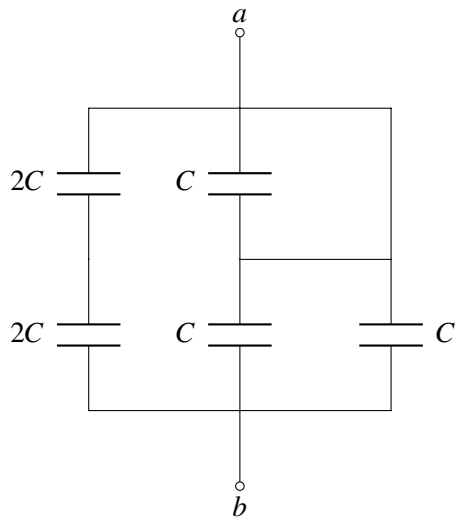

7. What is the total energy stored in capacitors in the circuit below?

