

3. Play With These Vectors (9 points)

Consider two periodic signals of length 4 represented by the vectors $\vec{v}_1 = \begin{bmatrix} -1 \\ 0 \\ 1 \\ -1 \end{bmatrix}$ and $\vec{v}_2 = \begin{bmatrix} 1 \\ -1 \\ 0 \\ 1 \end{bmatrix}$.

(a) (2 points) **Write the circulant matrix, $C_{\vec{v}_2}$, for \vec{v}_2 as defined in class.**

Solution:

$$C_{\vec{v}_2} = \begin{bmatrix} 1 & -1 & 0 & 1 \\ 1 & 1 & -1 & 0 \\ 0 & 1 & 1 & -1 \\ -1 & 0 & 1 & 1 \end{bmatrix}$$

(b) (2 points) **Write the cross-correlation of \vec{v}_1 with \vec{v}_2 in terms of \vec{v}_1 , \vec{v}_2 , and/or the circulant matrix $C_{\vec{v}_2}$.**

Solution:

$$\vec{\rho}_{\vec{v}_1 \vec{v}_2} = C_{\vec{v}_2} \vec{v}_1$$

(c) (1 point) **Calculate the second entry of the cross-correlation vector, i.e., the inner product between \vec{v}_1 and $\vec{v}_2^{(1)}$.**

Solution:

$$\begin{aligned} \langle \vec{v}_1, \vec{v}_2^{(1)} \rangle &= \left\langle \begin{bmatrix} -1 \\ 0 \\ 1 \\ -1 \end{bmatrix}, \begin{bmatrix} 1 \\ 1 \\ -1 \\ 0 \end{bmatrix} \right\rangle \\ &= -2 \end{aligned}$$

(d) (4 points) **Perform Gram-Schmidt on the vectors in the order $\{\vec{v}_2, \vec{v}_1\}$. You do not have to normalize the resulting vectors.**

Solution:

$$\begin{aligned} \vec{u}_1 &= \vec{v}_2 = \begin{bmatrix} 1 \\ -1 \\ 0 \\ 1 \end{bmatrix} \\ \vec{u}_2 &= \vec{v}_1 - \frac{\langle \vec{v}_1, \vec{u}_1 \rangle}{\langle \vec{u}_1, \vec{u}_1 \rangle} \vec{u}_1 = \begin{bmatrix} -1 \\ 0 \\ 1 \\ -1 \end{bmatrix} - \frac{\left\langle \begin{bmatrix} -1 \\ 0 \\ 1 \\ -1 \end{bmatrix}, \begin{bmatrix} 1 \\ -1 \\ 0 \\ 1 \end{bmatrix} \right\rangle}{\left\langle \begin{bmatrix} 1 \\ -1 \\ 0 \\ 1 \end{bmatrix}, \begin{bmatrix} 1 \\ -1 \\ 0 \\ 1 \end{bmatrix} \right\rangle} \begin{bmatrix} 1 \\ -1 \\ 0 \\ 1 \end{bmatrix} = \begin{bmatrix} -1 \\ 0 \\ 1 \\ -1 \end{bmatrix} + \frac{2}{3} \begin{bmatrix} 1 \\ -1 \\ 0 \\ 1 \end{bmatrix} = \begin{bmatrix} -\frac{1}{3} \\ -\frac{2}{3} \\ 1 \\ -\frac{1}{3} \end{bmatrix} \end{aligned}$$

4. Oh No! More Eigenspaces (12 points)

- (a) (6 points) Consider the matrix $\mathbf{A} = \begin{bmatrix} 4 & 0 & -12 \\ 0 & 4 & -12 \\ 0 & 0 & -2 \end{bmatrix}$. If the matrix \mathbf{A} is diagonalizable as $\mathbf{A} = \mathbf{V}\mathbf{\Lambda}\mathbf{V}^{-1}$, write out the matrices \mathbf{V} and $\mathbf{\Lambda}$ explicitly.

Solution:

$$\det(\mathbf{A} - \lambda\mathbf{I}) = \det \left(\begin{bmatrix} 4-\lambda & 0 & -12 \\ 0 & 4-\lambda & -12 \\ 0 & 0 & -2-\lambda \end{bmatrix} \right) = (4-\lambda)^2(-2-\lambda) = 0 \implies \lambda_1 = 4, \lambda_2 = 4, \lambda_3 = -2$$

$\lambda = 4$:

$$\text{Null}(\mathbf{A} - 4\mathbf{I}) = \text{Null} \left(\begin{bmatrix} 0 & 0 & -12 \\ 0 & 0 & -12 \\ 0 & 0 & -6 \end{bmatrix} \right) \implies \text{span} \left\{ \begin{bmatrix} 1 \\ 0 \\ 0 \end{bmatrix}, \begin{bmatrix} 0 \\ 1 \\ 0 \end{bmatrix} \right\}$$

$\lambda = -2$:

$$\text{Null}(\mathbf{A} + 2\mathbf{I}) = \text{Null} \left(\begin{bmatrix} 6 & 0 & -12 \\ 0 & 6 & -12 \\ 0 & 0 & 0 \end{bmatrix} \right) \implies \text{span} \left\{ \begin{bmatrix} 2 \\ 2 \\ 1 \end{bmatrix} \right\}$$

$$\mathbf{V} = \begin{bmatrix} 1 & 0 & 2 \\ 0 & 1 & 2 \\ 0 & 0 & 1 \end{bmatrix} \quad \mathbf{\Lambda} = \begin{bmatrix} 4 & 0 & 0 \\ 0 & 4 & 0 \\ 0 & 0 & -2 \end{bmatrix}$$

- (b) (1 point) The amount of water in a pump-reservoir system is represented by the state vector $\vec{w} = \begin{bmatrix} w_1 \\ w_2 \\ w_3 \end{bmatrix}$.

The state vector follows the state evolution equation $\vec{w}[n+1] = \mathbf{B}\vec{w}[n], \forall n \in \{0, 1, \dots\}$, where \mathbf{B} is the state transition matrix for this system represented in the figure below.

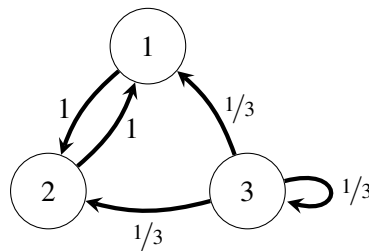

Write out the state transition matrix \mathbf{B} associated with this system.

Solution:

$$\mathbf{B} = \begin{bmatrix} 0 & 1 & 1/3 \\ 1 & 0 & 1/3 \\ 0 & 0 & 2/3 \end{bmatrix}$$

(c) (5 points) The eigenvalue/eigenvector pairs of the pump-reservoir system in part (b) are

$$\left(\lambda_1 = 1, \vec{u}_1 = \begin{bmatrix} 1 \\ 1 \\ 0 \end{bmatrix} \right), \left(\lambda_2 = -1, \vec{u}_2 = \begin{bmatrix} -1 \\ 1 \\ 0 \end{bmatrix} \right), \left(\lambda_3 = \frac{1}{3}, \vec{u}_3 = \begin{bmatrix} -1 \\ -1 \\ 2 \end{bmatrix} \right).$$

In this part, you are given two possible initial water levels at $n = 0$. For each case, **determine whether the system arrives at steady state** after a long period of time as $n \rightarrow \infty$. If it does, **calculate the water levels at steady state**. If it doesn't, **explain why not**.

- i. The initial water levels in the reservoirs are given by $\vec{a}[0] = \begin{bmatrix} 2 \\ 2 \\ 2 \end{bmatrix}$.

Solution:

We write $\vec{a}[0] = \alpha_1 \vec{u}_1 + \alpha_2 \vec{u}_2 + \alpha_3 \vec{u}_3$:

$$\begin{aligned} & \left[\begin{array}{ccc|c} 1 & -1 & -1 & 2 \\ 1 & 1 & -1 & 2 \\ 0 & 0 & 2 & 2 \end{array} \right] \xrightarrow[R_2 \leftarrow R_2 - R_1]{\Rightarrow} \left[\begin{array}{ccc|c} 1 & -1 & -1 & 2 \\ 0 & 2 & 0 & 0 \\ 0 & 0 & 2 & 2 \end{array} \right] \\ & \xrightarrow[R_3 \leftarrow \frac{1}{2} R_3]{R_2 \leftarrow \frac{1}{2} R_2} \left[\begin{array}{ccc|c} 1 & -1 & -1 & 2 \\ 0 & 1 & 0 & 0 \\ 0 & 0 & 1 & 1 \end{array} \right] \xrightarrow[R_1 \leftarrow R_1 + R_2 + R_3]{\Rightarrow} \left[\begin{array}{ccc|c} 1 & 0 & 0 & 3 \\ 0 & 1 & 0 & 0 \\ 0 & 0 & 1 & 1 \end{array} \right], \end{aligned}$$

which yields the solution $\alpha_1 = 3$, $\alpha_2 = 0$, and $\alpha_3 = 1$.

Therefore, $\lim_{n \rightarrow \infty} \mathbf{B}^n \vec{a}[0] = \lim_{n \rightarrow \infty} \mathbf{B}^n (3\vec{u}_1 + 0\vec{u}_2 + \vec{u}_3) = \lim_{n \rightarrow \infty} 3\mathbf{B}^n \vec{u}_1 + 1\mathbf{B}^n \vec{u}_3 = \lim_{n \rightarrow \infty} 3\lambda_1^n \vec{u}_1 +$

$$\lambda_3^n \vec{u}_3 = 3\vec{u}_1 = \begin{bmatrix} 3 \\ 3 \\ 0 \end{bmatrix}.$$

- ii. The initial water levels in the reservoirs are given by $\vec{b}[0] = \begin{bmatrix} 2 \\ 0 \\ 4 \end{bmatrix}$.

Solution:

We write $\vec{b}[0] = \beta_1 \vec{u}_1 + \beta_2 \vec{u}_2 + \beta_3 \vec{u}_3$:

$$\begin{aligned} & \left[\begin{array}{ccc|c} 1 & -1 & -1 & 2 \\ 1 & 1 & -1 & 0 \\ 0 & 0 & 2 & 4 \end{array} \right] \xrightarrow[R_2 \leftarrow R_2 - R_1]{\Rightarrow} \left[\begin{array}{ccc|c} 1 & -1 & -1 & 2 \\ 0 & 2 & 0 & -2 \\ 0 & 0 & 2 & 4 \end{array} \right] \\ & \xrightarrow[R_3 \leftarrow \frac{1}{2} R_3]{R_2 \leftarrow \frac{1}{2} R_2} \left[\begin{array}{ccc|c} 1 & -1 & -1 & 2 \\ 0 & 1 & 0 & -1 \\ 0 & 0 & 1 & 2 \end{array} \right] \xrightarrow[R_1 \leftarrow R_1 + R_2 + R_3]{\Rightarrow} \left[\begin{array}{ccc|c} 1 & 0 & 0 & 3 \\ 0 & 1 & 0 & -1 \\ 0 & 0 & 1 & 2 \end{array} \right], \end{aligned}$$

which yields the solution $\alpha_1 = 3$, $\alpha_2 = -1$, and $\alpha_3 = 2$.

Therefore, $\lim_{n \rightarrow \infty} \mathbf{B}^n \vec{b}[0] = \lim_{n \rightarrow \infty} \mathbf{B}^n (3\vec{u}_1 - \vec{u}_2 + 2\vec{u}_3) = \lim_{n \rightarrow \infty} 3\mathbf{B}^n \vec{u}_1 - \mathbf{B}^n \vec{u}_2 + 2\mathbf{B}^n \vec{u}_3 = \lim_{n \rightarrow \infty} 3\lambda_1^n \vec{u}_1 - \lambda_2^n \vec{u}_2 + 2\lambda_3^n \vec{u}_3$, which doesn't converge because $\lambda_2 = -1$. We conclude that the system will not reach steady state from the initial state $\vec{b}[0]$.

5. Dobby's Hobby (7 points)

Dobby the free house-elf is thinking of making a Black Forest sponge cake for a banquet. Unfortunately, he has two bags of cake ingredients that are already premixed with certain quantities of ingredients, neither of which has the desired amounts for his cake. The amount of baking ingredients (flour, sugar, and chocolate)

in the first bag (in pounds) is $\vec{b}_1 = \begin{bmatrix} 3 \\ 0 \\ 1 \end{bmatrix}$, while the second has the following amounts (in pounds) $\vec{b}_2 = \begin{bmatrix} 0 \\ 2 \\ 0 \end{bmatrix}$.

- (a) (2 points) If Dobby requires $\vec{r}_1 = \begin{bmatrix} 6 \\ 4 \\ 2 \end{bmatrix}$ (in pounds) for the sponge cake, **can he use a combination of the two bags to create a new bag with this amount?** If yes, **calculate how many of each bag Dobby needs.** If no, **explain why not.**

Solution:

Yes, $\vec{r}_1 \in \text{span}\{\vec{b}_1, \vec{b}_2\}$.

$$\vec{r}_1 = 2\vec{b}_1 + 2\vec{b}_2$$

- (b) (1 point) If the amount of ingredients he requires for the sponge cake is now $\vec{r}_2 = \begin{bmatrix} 1 \\ 0 \\ 2 \end{bmatrix}$, can he use a combination of the two bags to create a new bag with this amount? **Circle your answer.**

YES

NO

Solution:

No, $\vec{r}_2 \notin \text{span}\{\vec{b}_1, \vec{b}_2\}$.

- (c) (4 points) If your answer to part (b) is yes, then **solve for the exact combination of bags** that Dobby must use to get $\vec{r}_2 = \begin{bmatrix} 1 \\ 0 \\ 2 \end{bmatrix}$ pounds of ingredients in mixture. If your answer to part (b) is no, then **find the combination of the bags that results in the smallest error** as defined in class.

Solution:

Using least squares to approximate,

$$\mathbf{A}^T \mathbf{A} = \begin{bmatrix} 3 & 0 & 1 \\ 0 & 2 & 0 \end{bmatrix} \begin{bmatrix} 3 & 0 \\ 0 & 2 \\ 1 & 0 \end{bmatrix} = \begin{bmatrix} 10 & 0 \\ 0 & 4 \end{bmatrix}$$

$$(\mathbf{A}^T \mathbf{A})^{-1} = \frac{1}{40} \begin{bmatrix} 4 & 0 \\ 0 & 10 \end{bmatrix}$$

$$\mathbf{A}^T \vec{r}_2 = \begin{bmatrix} 3 & 0 & 1 \\ 0 & 2 & 0 \end{bmatrix} \begin{bmatrix} 1 \\ 0 \\ 2 \end{bmatrix} = \begin{bmatrix} 5 \\ 0 \end{bmatrix}$$

$$\vec{\hat{x}} = (\mathbf{A}^T \mathbf{A})^{-1} \mathbf{A}^T \vec{r}_2 = \frac{1}{40} \begin{bmatrix} 4 & 0 \\ 0 & 10 \end{bmatrix} \begin{bmatrix} 5 \\ 0 \end{bmatrix} = \begin{bmatrix} \frac{1}{2} \\ 0 \end{bmatrix}$$

PRINT your name and student ID: _____

6. Projections Properties (10 points)

- (a) (2 points) Let \mathbf{P} be a projection matrix. **Find the smallest positive integer** ($n \in \mathbb{Z}, n > 0$) **that satisfies** $\mathbf{P}^{1000} = \mathbf{P}^n$. **Justify your answer.**

Solution:

$$n = 1$$

Applying the projection \mathbf{P} once on a vector \vec{b} produces a vector $\vec{\hat{b}}$ in the column space of \mathbf{P} . Applying the projection \mathbf{P} again on $\vec{\hat{b}}$ will still result in $\vec{\hat{b}}$ because $\vec{\hat{b}}$ is already in the column space of \mathbf{P} . Therefore, applying the projection \mathbf{P} 1000 times is the same as applying \mathbf{P} once.

- (b) (3 points) **Show that the only possible eigenvalues of a projection matrix \mathbf{P} are $\lambda = 0$ and $\lambda = 1$.**

Solution:

Let λ, \vec{v} be an eigenvalue/eigenvector pair of \mathbf{P} , then we know

$$\mathbf{P}\vec{v} = \lambda\vec{v}$$

$$\mathbf{P}^2\vec{v} = \lambda^2\vec{v}$$

But we know that $\mathbf{P}^2 = \mathbf{P}$ since \mathbf{P} is a projection matrix, therefore:

$$\lambda^2\vec{v} = \mathbf{P}^2\vec{v} = \mathbf{P}\vec{v} = \lambda\vec{v}$$

By looking at the left hand side and the right hand side of the equation above,

$$\lambda(\lambda - 1)\vec{v} = \vec{0}$$

We know that $\vec{v} \neq \vec{0}$ because it is an eigenvector. Therefore,

$$\lambda = 0, 1$$

PRINT your name and student ID: _____

(c) (5 points) Consider the problem $\mathbf{A}\vec{x} = \vec{b}$, where $\mathbf{A} \in \mathbb{R}^{m \times n}$, $\vec{b} \in \mathbb{R}^m$, and $\vec{x} \in \mathbb{R}^n$ (and $m > n$). We are given the following:

- \vec{b} is not in the column space of \mathbf{A} .
- The first k columns of \mathbf{A} are linearly independent, and each one of the remaining columns of \mathbf{A} is a linear combination of the first k columns, where $0 < k < n$.

Find a matrix $\tilde{\mathbf{A}}$, such that the projection matrix $\tilde{\mathbf{P}} = \tilde{\mathbf{A}}(\tilde{\mathbf{A}}^T \tilde{\mathbf{A}})^{-1} \tilde{\mathbf{A}}^T$ projects \vec{b} onto the subspace spanned by the columns of \mathbf{A} . **Justify your answer.**

Solution:

Let $\tilde{\mathbf{A}}$ be an $m \times k$ matrix, where the k columns of $\tilde{\mathbf{A}}$ correspond to the first k columns of \mathbf{A} , which are linearly independent. Then, $\tilde{\mathbf{A}}^T \tilde{\mathbf{A}}$ will be invertible.

This solution works because the column space of \mathbf{A} , given by the span of the first k columns of \mathbf{A} , is the same subspace as the column space of $\tilde{\mathbf{A}}$, which has exactly these k columns.

7. Circuits Warmup (8 points)

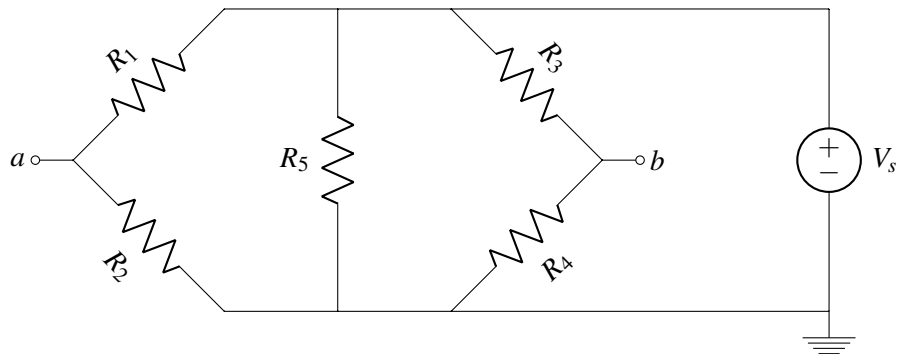

- (a) (2 points) **Calculate the Thévenin equivalent voltage** v_{th} of the circuit above between the terminals labeled a and b , such that $v_{th} = v_a - v_b$.

Solution:

We can calculate the Thévenin equivalent voltage by observing that v_a and v_b are given by the voltage dividers at each branch.

$$v_{th} = V_s \cdot \left(\frac{R_2}{R_1 + R_2} - \frac{R_4}{R_3 + R_4} \right)$$

- (b) (2 points) **Calculate the Thévenin equivalent resistance** R_{th} of the circuit above between the terminals labeled a and b .

Solution:

We can find the equivalent resistance by turning off the voltage source V_s . This shorts the top and bottom nodes of the circuit, resulting in the equivalent circuit below.

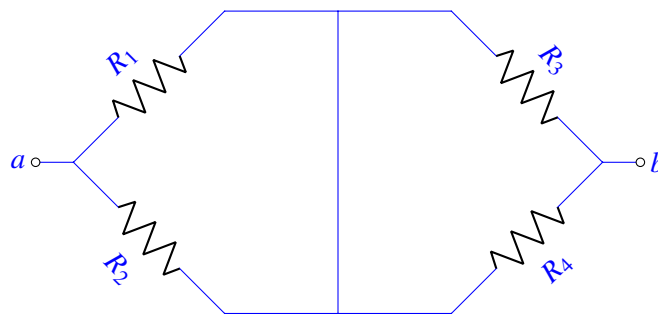

$$R_{th} = R_1 \parallel R_2 + R_3 \parallel R_4$$

PRINT your name and student ID: _____

- (c) (2 points) Now consider the following circuit below with a comparator connected to the terminals labeled a and b . Assume that $V_s = 9\text{ V}$, $R_1 = R_4 = R_5 = R$, and $R_2 = R_3 = 2R$. **Find** v_{out_1} .

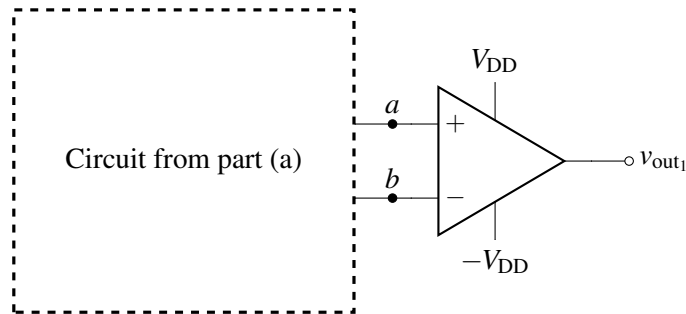

Solution:

Looking at the bridge circuit from part (a), we first calculate v_a and v_c .

$$v_a = \frac{2R}{2R+R} \cdot 9\text{ V} = 6\text{ V} \quad v_c = \frac{R}{R+2R} \cdot 9\text{ V} = 3\text{ V}$$

The comparator will therefore output the positive rail V_{DD} .

$$v_{\text{out}_1} = V_{\text{DD}}$$

- (d) (2 points) Now consider the following circuit below with an op-amp in negative feedback connected to the terminals labeled a and b . Assume that $V_s = 9\text{ V}$, $R_1 = R_4 = R_5 = R$, and $R_2 = R_3 = 2R$. **Find** v_{out_2} **assuming that** $R_G = R$.

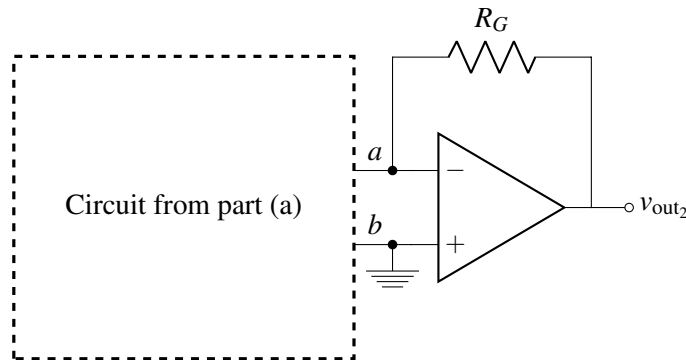

Solution:

Using the calculated values from part (c), we find that the Thévenin equivalent voltage $v_{\text{th}} = v_a = v_c = 3\text{ V}$. From part (b), we find that the Norton equivalent resistance $R_{\text{th}} = 2 \cdot \frac{2R \cdot R}{2R+R} = \frac{4}{3}R$ after substituting the values for R_1 , R_2 , R_3 , and R_4 into the expression for R_{th} .

Since the inverting amplifier has a gain of $-\frac{R_G}{R_{\text{th}}}$, we get:

$$v_{\text{out}_2} = -\frac{R_G}{R_{\text{th}}} \cdot 3\text{ V} = -\frac{9}{4}\text{ V}$$

PRINT your name and student ID: _____

8. 16A's Hottest New Product (16 points)

It's 2017, and The Plastics from Mean Girls High (coincidentally sharing a name with the classic 2004 teen comedy) have decided that defining an inner product as a dot product is, like, so 1843. Luckily, they are well-versed in college mathematics and realize that the inner product is really a mathematical operation within vector spaces. And so, they have defined a new inner product for this year's summer catalog! Specifically, they've defined the set

$$\mathbb{S} = \left\{ f(x) \mid f(x) = \begin{cases} a & \text{if } 0 \leq x < 1 \\ b & \text{if } 1 \leq x < 2 \\ 0 & \text{otherwise} \end{cases} \text{ for } a, b \in \mathbb{R} \right\}.$$

In words, they've defined the set of all real step functions with domain $[0, 2)$, where the two step intervals are $[0, 1)$ and $[1, 2)$.

For example, here is a valid function in \mathbb{S} , where $a = 1$ and $b = -1$.

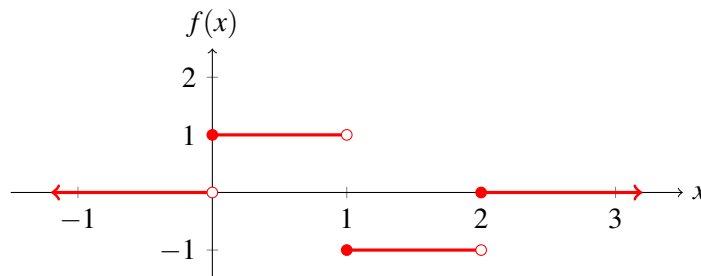

Finally, the actual product: the Plastic inner product, henceforth denoted as $p(f_1(x), f_2(x))$, is defined as $p(f_1(x), f_2(x)) = \int_0^2 f_1(x)f_2(x)dx$, the **net area between the function $f_1(x)f_2(x)$ and the x -axis**. We have shown in class that the set of all real functions, with the normal addition and scaling operations, constitutes a vector space. We are given that \mathbb{S} is a valid subspace of this vector space.

Part (a) starts on the next page.

This space was intentionally left blank.

PRINT your name and student ID: _____

(a) (3 points) Let $f_1(x)$ and $f_2(x)$ be defined as follows:

$$f_1(x) = \begin{cases} a_1 & \text{if } 0 \leq x < 1 \\ b_1 & \text{if } 1 \leq x < 2 \\ 0 & \text{otherwise} \end{cases} \quad f_2(x) = \begin{cases} a_2 & \text{if } 0 \leq x < 1 \\ b_2 & \text{if } 1 \leq x < 2 \\ 0 & \text{otherwise} \end{cases}$$

where $a_1, a_2, b_1, b_2 \in \mathbb{R}$.

Show that the Plastic inner product can be calculated as $p(f_1(x), f_2(x)) = a_1a_2 + b_1b_2$.

Solution:

Let us first calculate $f_1(x)f_2(x)$:

$$f_1(x)f_2(x) = \begin{cases} a_1 & \text{if } 0 \leq x < 1 \\ b_1 & \text{if } 1 \leq x < 2 \\ 0 & \text{otherwise} \end{cases} \cdot \begin{cases} a_2 & \text{if } 0 \leq x < 1 \\ b_2 & \text{if } 1 \leq x < 2 \\ 0 & \text{otherwise} \end{cases} = \begin{cases} a_1a_2 & \text{if } 0 \leq x < 1 \\ b_1b_2 & \text{if } 1 \leq x < 2 \\ 0 & \text{otherwise} \end{cases}$$

We know that $p(f_1(x), f_2(x)) = \int_0^2 f_1(x)f_2(x)dx$, so we calculate:

$$\begin{aligned} p(f_1(x), f_2(x)) &= \int_0^2 f_1(x)f_2(x)dx \\ &= \int_0^1 f_1(x)f_2(x)dx + \int_1^2 f_1(x)f_2(x)dx \quad (f_1(x)f_2(x) \text{ is constant in each interval}) \\ &= \int_0^1 a_1a_2dx + \int_1^2 b_1b_2dx \quad \left(\int_n^{n+1} kdx = k \text{ for a constant } k \right) \\ &= a_1a_2 + b_1b_2 \end{aligned}$$

(b) (9 points) This part consists of three subparts (b)i.-(b)iii. In these subparts, you will demonstrate that the Plastic inner product is a valid inner product by showing that it follows the three axioms of inner products: symmetry, linearity, and non-negativity (over \mathbb{R}).

i. **Show that the Plastic inner product satisfies symmetry.** That is, show that for all $f_1(x), f_2(x) \in \mathbb{S}$, $p(f_1(x), f_2(x)) = p(f_2(x), f_1(x))$.

Solution:

Let $f_1(x)$ and $f_2(x)$ be two functions in \mathbb{S} .

Then,

$$\begin{aligned} p(f_1(x), f_2(x)) &= \int_0^2 f_1(x)f_2(x)dx \\ &= \int_0^1 f_1(x)f_2(x)dx + \int_1^2 f_1(x)f_2(x)dx \\ &= \int_0^1 f_2(x)f_1(x)dx + \int_1^2 f_2(x)f_1(x)dx \\ &= \int_0^2 f_2(x)f_1(x)dx \\ &= p(f_2(x), f_1(x)) \end{aligned}$$

PRINT your name and student ID: _____

ii. **Show that the Plastic inner product satisfies linearity.** That is, show that for all $f_1(x), f_2(x), f_3(x) \in \mathbb{S}$ and all $k \in \mathbb{R}$,

i. $p(f_1(x) + f_2(x), f_3(x)) = p(f_1(x), f_3(x)) + p(f_2(x), f_3(x))$ and

ii. $p(k \cdot f_1(x), f_2(x)) = k \cdot p(f_1(x), f_2(x))$.

Solution:

Let $f_1(x), f_2(x)$, and $f_3(x)$ be three functions in \mathbb{S} .

i.

$$\begin{aligned} p(f_1(x) + f_2(x), f_3(x)) &= \int_0^2 (f_1(x) + f_2(x))f_3(x)dx \\ &= \int_0^2 f_1(x)f_3(x) + f_2(x)f_3(x)dx \\ &= \int_0^2 f_1(x)f_3(x)dx + \int_0^2 f_2(x)f_3(x)dx \\ &= p(f_1(x), f_3(x)) + p(f_2(x), f_3(x)) \end{aligned}$$

ii.

$$\begin{aligned} p(k \cdot f_1(x), f_2(x)) &= \int_0^2 (k \cdot f_1(x))f_2(x)dx \\ &= \int_0^2 k \cdot f_1(x)f_2(x)dx \\ &= k \cdot \int_0^2 f_1(x)f_2(x)dx \\ &= k \cdot p(f_1(x), f_2(x)) \end{aligned}$$

iii. **Show that the Plastic inner product satisfies the non-negativity axiom of inner products.**

That is, show that

i. $p(f(x), f(x)) \geq 0$ for all $f(x) \in \mathbb{S}$ and

ii. $p(f(x), f(x)) = 0$ if and only if $f(x) \equiv 0$.

Solution:

Let $f_1(x)$ be a function in \mathbb{S} , where

$$f(x) = \begin{cases} a & \text{if } 0 \leq x < 1 \\ b & \text{if } 1 \leq x < 2 \\ 0 & \text{otherwise} \end{cases} \quad \text{for some } a, b \in \mathbb{R}$$

Then,

$$p(f(x), f(x)) = \int_0^2 (f(x))^2 dx = a^2 + b^2 \geq 0 \text{ for any } a, b \in \mathbb{R}.$$

Moreover, $p(f(x), f(x)) = a^2 + b^2 = 0$ if and only if $a = b = 0$ (since $a, b \in \mathbb{R}$).

PRINT your name and student ID: _____

(c) (2 points) **Calculate the norm** of

$$\hat{f}(x) = \begin{cases} 1 & \text{if } 0 \leq x < 1 \\ 2 & \text{if } 1 \leq x < 2 \\ 0 & \text{otherwise} \end{cases}$$

according to the Plastic inner product.

Solution:

We know that $\|f(x)\| = \sqrt{\int_0^2 (f(x))^2 dx} = \sqrt{a^2 + b^2}$. Therefore,

$$\|\hat{f}_1(x)\| = \sqrt{1^2 + 2^2} = \sqrt{1 + 4} = \sqrt{5}.$$

(d) (2 points) **Determine whether $\hat{f}(x)$ from part (c) and $\tilde{f}(x)$ are orthogonal**, according to the Plastic inner product, where $\tilde{f}(x)$ is as follows:

$$\tilde{f}(x) = \begin{cases} -1 & \text{if } 0 \leq x < 1 \\ 2 & \text{if } 1 \leq x < 2 \\ 0 & \text{otherwise} \end{cases}$$

Justify your answer.

Solution:

Two functions are orthogonal, according to the Plastic inner product, if and only if their Plastic inner product is equal to 0.

$$p(\hat{f}(x), \tilde{f}(x)) = \int_0^2 \hat{f}(x)\tilde{f}(x)dx = 1 \cdot (-1) + 2 \cdot 2 = 3$$

Therefore, the two functions are not orthogonal.

9. Gram-Schmidt Circuits (20 points)

In this problem, we will build a circuit that generates a vector that is orthogonal to a reference vector $\vec{x} = \begin{bmatrix} 1 \\ -2 \end{bmatrix}$ while preserving the span of \vec{x} and the input vector \vec{u} . The circuit has two inputs u_1 and u_2 corresponding to the components of the input vector $\vec{u} = \begin{bmatrix} u_1 \\ u_2 \end{bmatrix}$. It also has two outputs v_1 and v_2 corresponding to the components of the output vector $\vec{v} = \begin{bmatrix} v_1 \\ v_2 \end{bmatrix}$, such that \vec{v} is orthogonal to the reference vector \vec{x} ($\langle \vec{v}, \vec{x} \rangle = 0$) and $\text{span}\{\vec{x}, \vec{u}\} = \text{span}\{\vec{x}, \vec{v}\}$. In other words, the circuit performs Gram-Schmidt with respect to the reference vector \vec{x} without normalizing the resulting vector.

Assume that all values in this problem are represented as voltages.

- (a) (8 points) To implement this orthogonalizing circuit, let's start by designing a circuit that just calculates the projection $\vec{\hat{u}} = \begin{bmatrix} \hat{u}_1 \\ \hat{u}_2 \end{bmatrix}$ of an input vector $\vec{u} = \begin{bmatrix} u_1 \\ u_2 \end{bmatrix}$ onto the subspace spanned by the reference vector $\vec{x} = \begin{bmatrix} 1 \\ -2 \end{bmatrix}$.

Recall that

$$\vec{\hat{u}} = \text{proj}_{\vec{x}} \vec{u} = \frac{\langle \vec{u}, \vec{x} \rangle}{\langle \vec{x}, \vec{x} \rangle} \vec{x} = \frac{\left\langle \begin{bmatrix} u_1 \\ u_2 \end{bmatrix}, \begin{bmatrix} 1 \\ -2 \end{bmatrix} \right\rangle}{\left\langle \begin{bmatrix} 1 \\ -2 \end{bmatrix}, \begin{bmatrix} 1 \\ -2 \end{bmatrix} \right\rangle} \begin{bmatrix} 1 \\ -2 \end{bmatrix} = \frac{u_1 - 2u_2}{5} \begin{bmatrix} 1 \\ -2 \end{bmatrix}.$$

Design a circuit that generates the projection vector $\vec{\hat{u}}$ for the input vector \vec{u} . Your circuit should have two inputs u_1 and u_2 and two outputs \hat{u}_1 and \hat{u}_2 . You may use up to 3 op-amps and as many resistors as you like.

Solution:

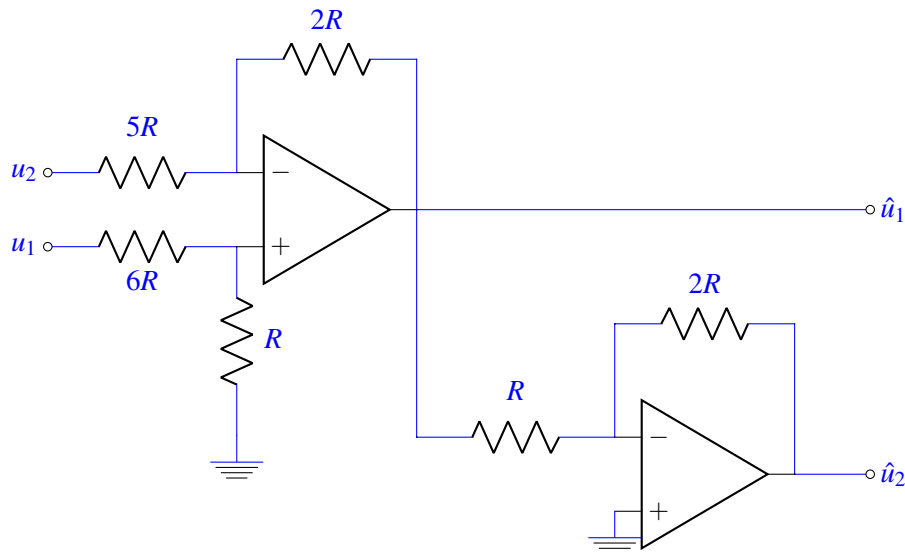

PRINT your name and student ID: _____

(b) (4 points) Now that you have \hat{u}_1 and \hat{u}_2 , the components of the projection vector $\vec{\hat{u}}$, you will now design two circuits to complete the orthogonalizing process. They should output v_1 and v_2 , the components of the output vector \vec{v} , such that \vec{v} is orthogonal to the reference vector \vec{x} ($\langle \vec{v}, \vec{x} \rangle = 0$).

i. **Design the circuit that outputs v_1 .** Your circuit may use u_1 , u_2 , \hat{u}_1 , and \hat{u}_2 as inputs and should output v_1 . You may use up to 2 op-amps and as many resistors as you like.

Solution:

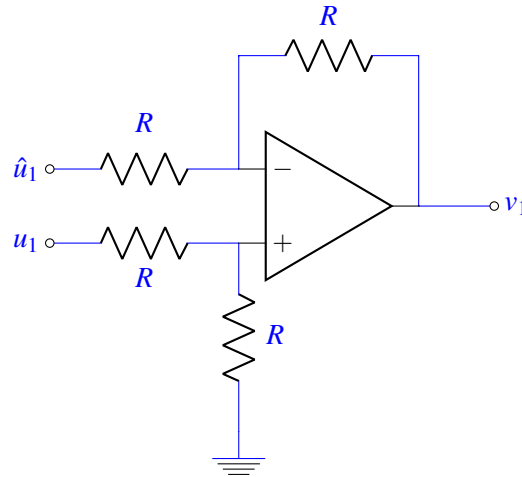

ii. **How would you modify the circuit from part (b)i.**, such that it will now output v_2 ? You may describe using words.

Solution:

Replace the input voltage u_1 with u_2 and the input voltage \hat{u}_1 with \hat{u}_2 .

PRINT your name and student ID: _____

- (c) (8 points) Now assume that you only have voltage sources that produce a voltage of either u_1 or u_2 as well as resistors. Using only these voltage sources and as many resistors as you like, **design a circuit that just outputs** v_2 . Your circuit should use u_1 and u_2 as inputs and should output v_2 as a voltage across a resistor. Mark clearly on your circuit the polarity in which v_2 is measured.

Hint: This circuit should perform the following operation:

$$v_2 = \frac{2}{5}u_1 + \frac{1}{5}u_2$$

Solution:

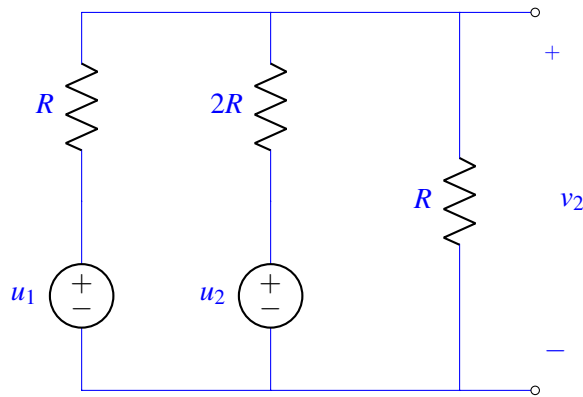

10. When There Is No Democracy Amongst Errors (14 points)

Whenever we get an overdetermined system of equations, we assume that all measurements are noisy and treat them ‘equally.’ However, we sometimes have more ‘confidence’ in some measurements than in others. For example, if you have two measuring tapes – one with very clear markings and another with faded markings, you would trust the measurement of the clear tape more. In this question, you’ll discover how to solve for the minimum error solution when errors don’t carry the same weight.

(a) (3 points) Consider the case when x is a scalar and you have two measurements:

$$\begin{cases} a_1x = b_1 \\ a_2x = b_2 \end{cases}$$

If \hat{x} is an estimate for x , then the squared error for measurement 1 is

$$e_1^2 = (a_1\hat{x} - b_1)^2,$$

and the squared error in measurement 2 is

$$e_2^2 = (a_2\hat{x} - b_2)^2.$$

Instead of minimizing the sum $e_1^2 + e_2^2$, you want to minimize a ‘weighted’ sum of these errors. Specifically, we want to minimize the following error metric:

$$\|e_w\|^2 = w_1^2 e_1^2 + w_2^2 e_2^2,$$

where $w_1, w_2 > 0$. **Find the value of \hat{x}** in terms of a_1, a_2, b_1, b_2, w_1 , and w_2 that minimizes this error metric $\|e_w\|^2$.

Hint: Use differentiation.

Solution:

$$\begin{aligned} \frac{d\|e_w\|^2}{dx} &= \frac{d}{dx} (w_1^2 e_1^2 + w_2^2 e_2^2) \\ &= \frac{d}{dx} (w_1^2 (a_1x - b_1)^2 + w_2^2 (a_2x - b_2)^2) \\ &= 2a_1 w_1^2 (a_1x - b_1) + 2a_2 w_2^2 (a_2x - b_2) \\ &= 2a_1^2 w_1^2 x - 2a_1 w_1^2 b_1 + 2a_2^2 w_2^2 x - 2a_2 w_2^2 b_2 = 0 \\ \hat{x} &= \frac{a_1 w_1^2 b_1 + a_2 w_2^2 b_2}{a_1^2 w_1^2 + a_2^2 w_2^2} \end{aligned}$$

PRINT your name and student ID: _____

Consider the system of linear equations given by $\mathbf{A}\vec{x} = \vec{b}$, where $\mathbf{A} \in \mathbb{R}^{m \times n}$ (with $m > n$), $\vec{x} \in \mathbb{R}^n$, and $\vec{b} \in \mathbb{R}^m$.

Specifically, $\mathbf{A} = \begin{bmatrix} | & | & & | \\ \vec{a}_1 & \vec{a}_2 & \cdots & \vec{a}_n \\ | & | & & | \end{bmatrix} = \begin{bmatrix} - & \vec{\alpha}_1^T & - \\ - & \vec{\alpha}_2^T & - \\ & \vdots & \\ - & \vec{\alpha}_m^T & - \end{bmatrix}$.

Assume that $\vec{\hat{x}}$ is an estimate for \vec{x} . Then, the individual measurement errors corresponding to that estimate $\vec{\hat{x}}$ are given by

$$e_i = \vec{\alpha}_i^T \vec{\hat{x}} - b_i \quad \text{for } i = 1, 2, \dots, m.$$

Let us weigh each error with weights w_1, w_2, \dots, w_m , such that $w_i > 0$ for all $i = 1, 2, \dots, m$.

Specifically, the i^{th} component of the weighted error is given by

$$\vec{e}_w[i] = w_i \cdot e_i.$$

(b) (2 points) If $\vec{e}_w = \mathbf{W}\vec{e}$, write out the matrix \mathbf{W} .

Solution:

$$\mathbf{W} = \begin{bmatrix} w_1 & 0 & 0 & \cdots & 0 \\ 0 & w_2 & 0 & \cdots & 0 \\ 0 & 0 & w_3 & \cdots & 0 \\ \vdots & \vdots & \vdots & \ddots & \vdots \\ 0 & 0 & 0 & 0 & w_m \end{bmatrix}$$

(c) (3 points) The weighted error vector \vec{e}_w can be rewritten as

$$\vec{e}_w = \mathbf{A}_w \vec{\hat{x}} - \vec{b}_w.$$

Write \mathbf{A}_w and \vec{b}_w in terms of \mathbf{A} , \vec{b} , and \mathbf{W} .

Solution:

$$\begin{aligned} \vec{e}_w &= \mathbf{W}\vec{e} = \mathbf{W}(\mathbf{A}\vec{\hat{x}} - \vec{b}) = \mathbf{W}\mathbf{A}\vec{\hat{x}} - \mathbf{W}\vec{b} \\ \mathbf{A}_w &= \mathbf{W}\mathbf{A} & \vec{b}_w &= \mathbf{W}\vec{b} \end{aligned}$$

(d) (2 points) Consider the weighted error \vec{e}_w with the minimum norm. Which subspace is this minimum norm weighted error vector \vec{e}_w orthogonal to?

Solution:

The minimum norm weighted error vector is orthogonal to $\text{colspan}(\mathbf{A}_w)$, or $\text{colspan}(\mathbf{W}\mathbf{A})$.

PRINT your name and student ID: _____

- (e) (4 points) **Derive the exact expression for the estimate** \vec{x} in terms of \mathbf{A} , \vec{b} , and \mathbf{W} that minimizes the squared norm of the weighted error, i.e., that minimizes $\|\vec{e}_w\|^2$.

Solution:

The weighted least squares problem has basically become a linear least squares problem, where we want to minimize the squared norm of the weighted error \vec{e}_w , where $\vec{e}_w = \mathbf{A}_w \vec{x} - \vec{b}_w$.

Applying the least squares formula, we get:

$$\begin{aligned}\vec{x} &= (\mathbf{A}_w^T \mathbf{A}_w)^{-1} \mathbf{A}_w^T \vec{b}_w \\ &= ((\mathbf{W}\mathbf{A})^T \mathbf{W}\mathbf{A})^{-1} (\mathbf{W}\mathbf{A})^T \mathbf{W}\vec{b} \\ &= (\mathbf{A}^T \mathbf{W}^T \mathbf{W}\mathbf{A})^{-1} \mathbf{A}^T \mathbf{W}^T \mathbf{W}\vec{b} \\ &= (\mathbf{A}^T \mathbf{W}^2 \mathbf{A})^{-1} \mathbf{A}^T \mathbf{W}^2 \vec{b}\end{aligned}$$

PRINT your name and student ID: _____

11. Stranger Circuits (24 points)

Popular streaming and content creating website EE16A-Flix is filming the second season of their popular 80's sci-fi thriller Stranger Circuits. To make the soundtrack, they have hired you to design a Theremin, a thematically appropriate instrument that is played with two hands. The musician's left hand controls the amplitude (loudness) of the instrument, and the musician's right hand controls the frequency (pitch). One interesting feature of a Theremin is that the musician playing it never needs to make contact with the instrument.

Assume that the permittivity of air is equal to the permittivity of free space ϵ_0 and that the musician (depicted below) is grounded.

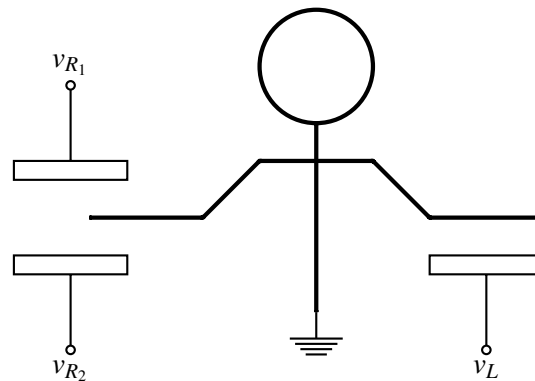

- (a) (2 points) Let's begin with the circuit that performs amplitude control. First, examine the physical model of the system:

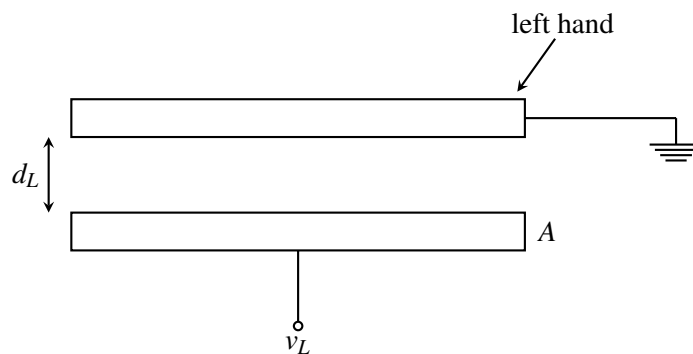

Find an expression for the capacitance C_L as a function of d_L , the distance between the musician's hand and the Theremin's amplitude plate, the area of the plates A , and the permittivity ϵ_0 . Assume that the musician's hand and the amplitude plate are both perfect conductors, forming a parallel plate capacitor with air in between.

Solution:

$$C_L = \frac{\epsilon_0 A}{d_L}$$

PRINT your name and student ID: _____

- (b) (6 points) Let's design a switched-capacitor circuit that takes an input v_{theremin} (we'll see where v_{theremin} comes from later on) and amplifies it by a *negative* value, so that $v_{\text{out}} = -aC_L v_{\text{theremin}}$ in one of the phases.

Draw and label the missing components as well as the missing '+' and '-' labels on the terminals of the op-amp in the following circuit. If your design uses switches, please label each of the switches ϕ_k to denote that it is closed in phase ϕ_k . You do not have to use actual numbers for component values, but you must use the capacitor C_L . **Find the value of a for your circuit.** You may use as many switches and capacitors as you like, but you may only place one component in each box.

Hint: This circuit should look familiar!

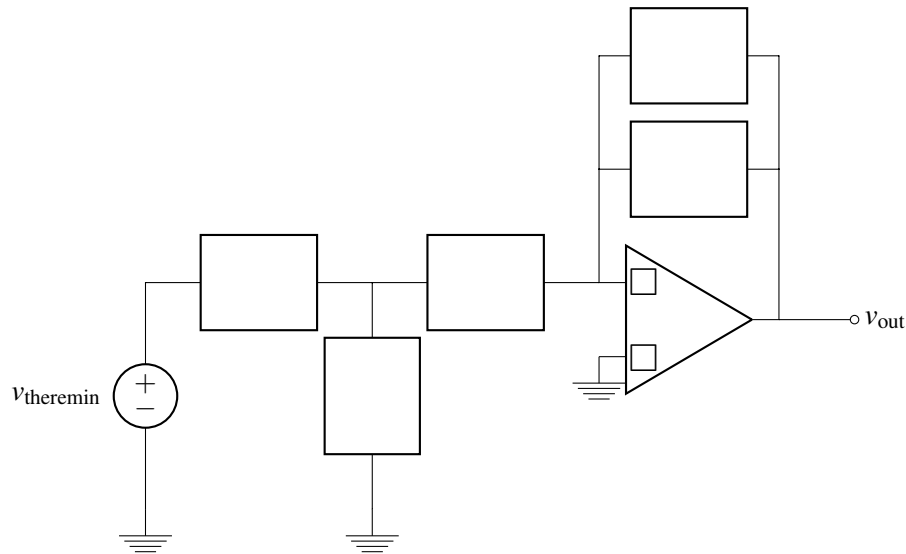

Solution:

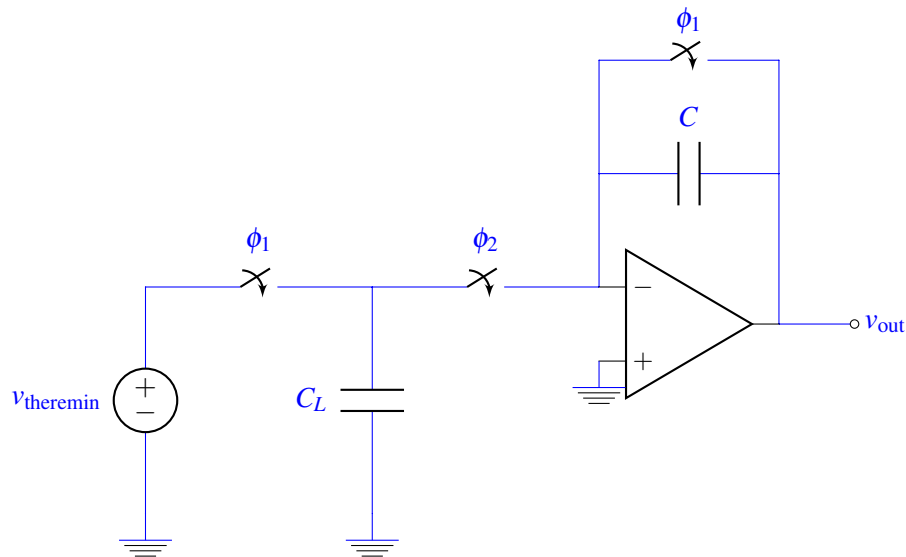

$$\text{Phase } \phi_2 : v_{\text{out}} = -\frac{C_L}{C} v_{\text{theremin}} \implies a = \frac{1}{C}$$

PRINT your name and student ID: _____

(c) (3 points) Now let's take a look at the right hand, which performs pitch control. First, let's look at our physical model of the system:

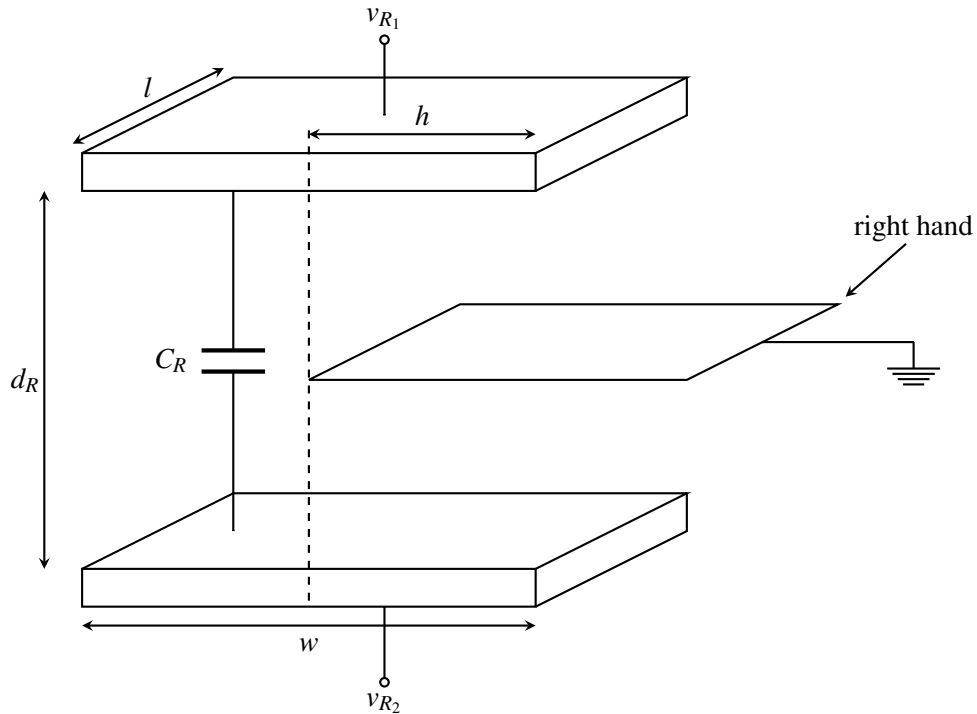

The cap C_R is the parallel plate capacitance whose plate area is the area where there is no hand. **Find an expression for the capacitance C_R between v_{R1} and v_{R2} as a function of h , the distance by which the musician's right hand goes between the two Theremin plates, w , l , and ϵ_0 .** The material between the hand and the plate is air. The cross-sectional area of the plates when there is no hand is $l \cdot w$. Your expression should apply for $0 \leq h \leq w$.

Solution:

$$C_R = \frac{\epsilon_0 w l}{d_R} - \frac{\epsilon_0 h l}{d_R}$$

PRINT your name and student ID: _____

- (d) (2 points) We want our Theremin to output a musical waveform, so it must oscillate. Let's break the oscillator circuit into parts. First, suppose that you have the following circuit:

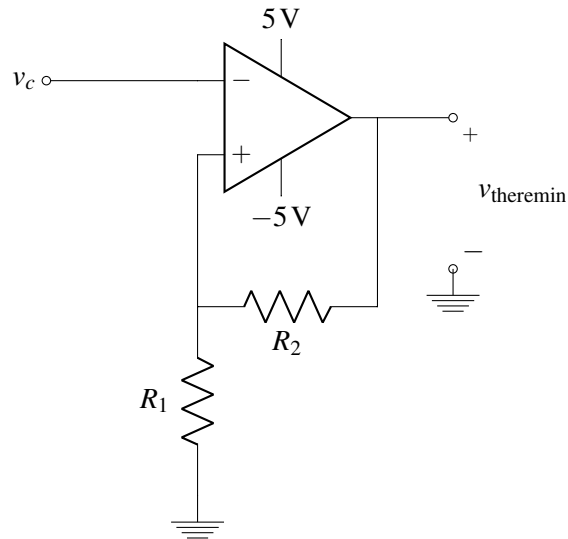

The input and output voltages as a function of time are shown on the following two axes. **Find the voltage v_x** (shown on the first set of axes) that will result in the $v_{\text{theremin}}(t)$ plot shown below.

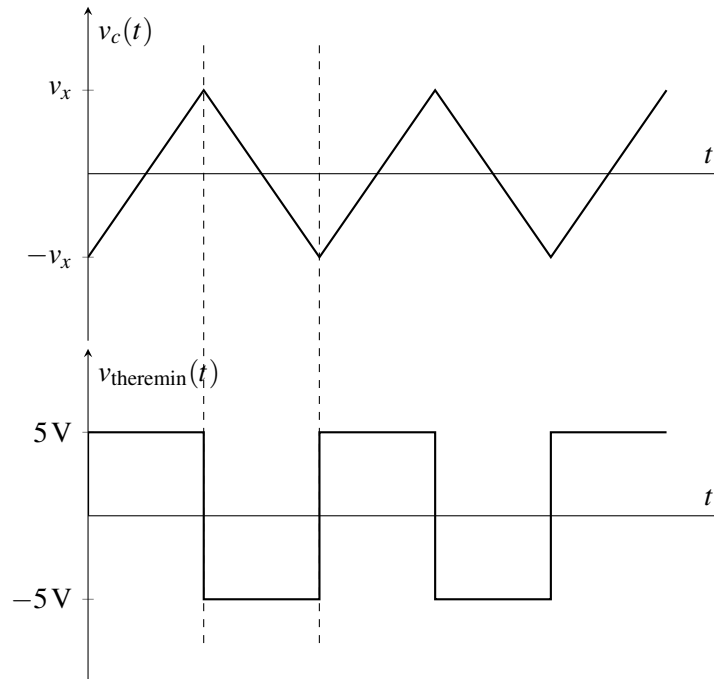

Solution:

$$v_x = \frac{R_1}{R_1 + R_2} \cdot 5 \text{ V}$$

PRINT your name and student ID: _____

(e) (3 points) Now consider the following circuit:

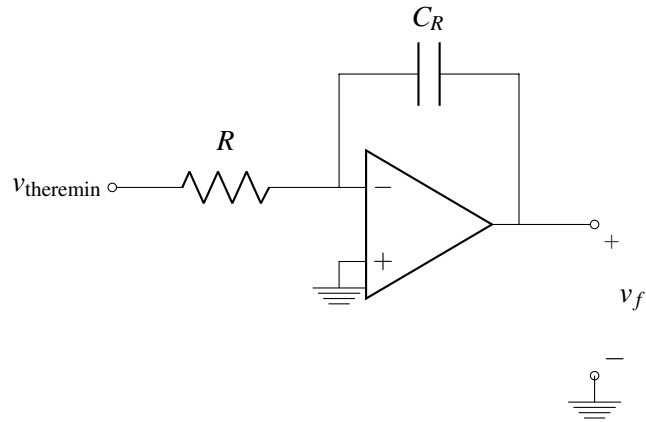

The following plot shows the input voltage $v_{theremin}(t)$ as a function of time:

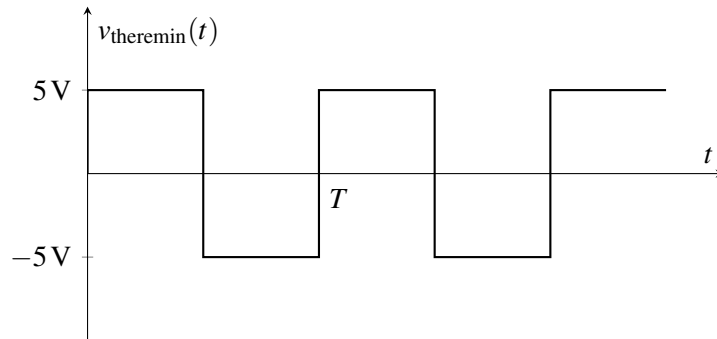

Plot the output voltage $v_f(t)$ as a function of time on the axes below. Label your axes. Axis labels should be in terms of C_R , R , and T , the period of the input voltage $v_{theremin}(t)$. Assume that the initial voltage on the capacitor is whatever it needs to be to make the average of the voltage $v_f(t)$ equal to zero over one period.



Solution:

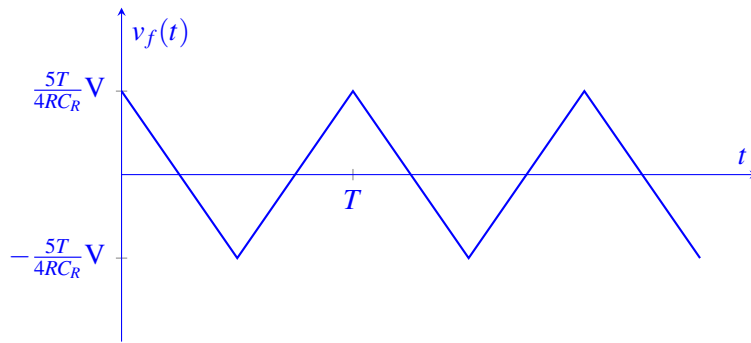

- (f) (4 points) **Complete the oscillator circuit below** by drawing any necessary components in the box. You may use at most one op-amp and as many resistors as you like.

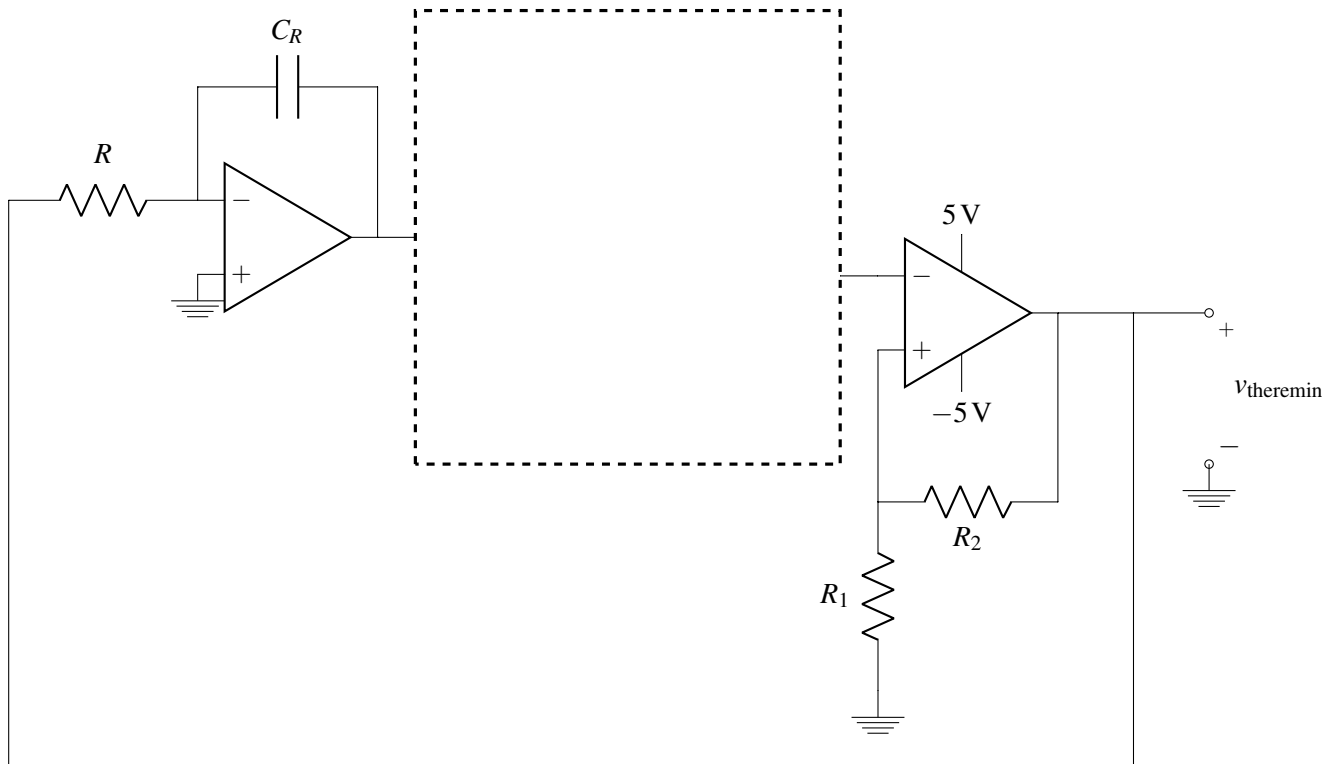

Solution:

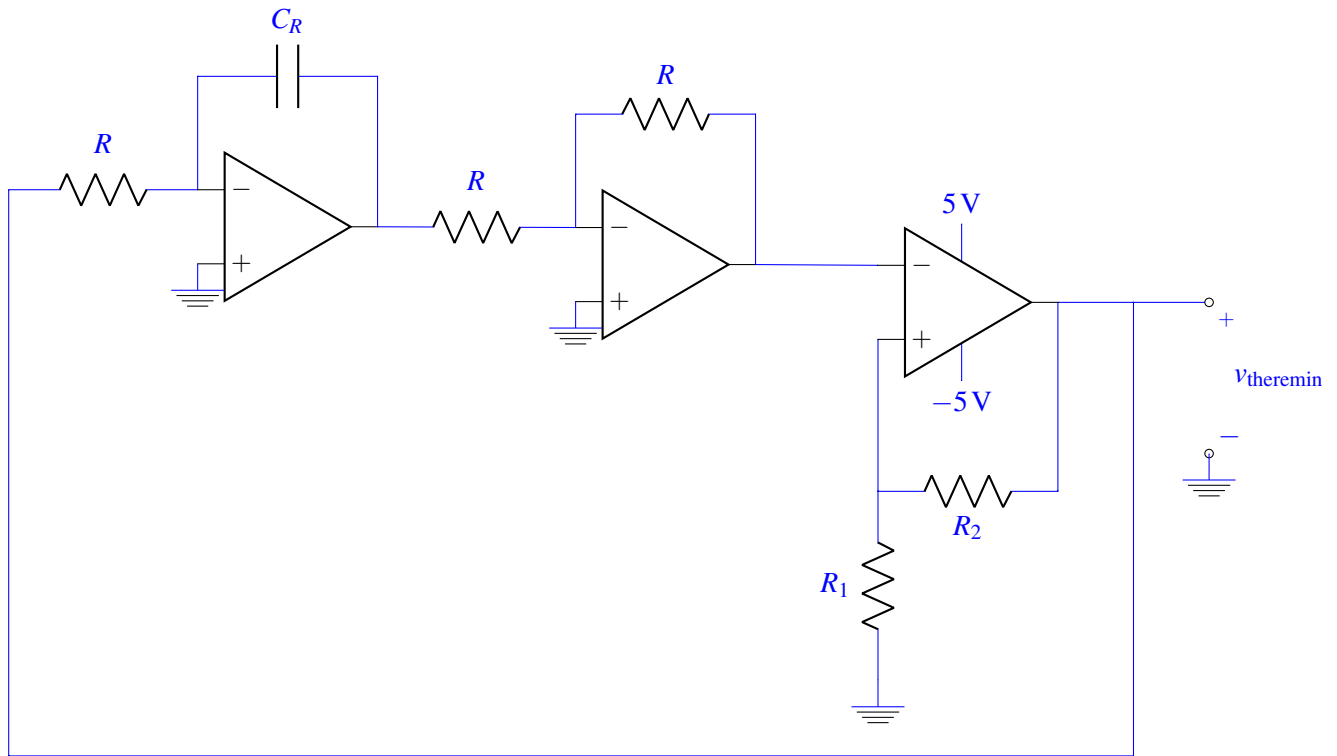

- (g) (4 points) **Find the frequency of oscillation** ($\frac{1}{T}$) as a function of R_1 , R_2 , R , and C_R . If you have other resistors in your circuit that affect your result, choose values for them.

Solution:

From part (d) and part (e), we know that $v_f = -v_c$. Therefore,

$$\frac{5T}{4RC_R} V = \frac{R_1}{R_1 + R_2} \cdot 5V$$

$$T = \frac{4RR_1C_R}{R_1 + R_2} \implies \frac{1}{T} = \frac{R_1 + R_2}{4RR_1C_R}$$

12. OMP Box (20 points)

Your friend who goes to the school on the other side of the bay says that they have several specialized functions and that they need your help to put together an OMP box. You gladly agree to help because you learned a lot of OMP in EE16A. Your friend tells you that there are 100 devices communicating to the OMP box. Their songs are $\vec{s}_0, \vec{s}_1, \dots, \vec{s}_{99} \in \mathbb{R}^{40}$, and **they are all normalized**, i.e., $\|\vec{s}_i\| = 1$ for all $i \in \{0, 1, \dots, 99\}$. At any given time, at most m of them are transmitting simultaneously. We denote their ‘messages’ as a_1, a_2, \dots, a_{99} . If a device, say the i^{th} device, wants to send the message a_i , then it sends $a_i \vec{s}_i$. The OMP box gets a combination of circularly shifted versions of the signals transmitted by these devices and we denote the received signal at the OMP box by \vec{r} .

Note: Assume that vectors are zero-indexed, i.e., $\vec{v} = \begin{bmatrix} v[0] \\ v[1] \\ \vdots \\ v[N-1] \end{bmatrix}$.

- (a) (2 points) If the song length is 40 and the number of devices is 100, **can the unshifted versions of the songs be perfectly orthogonal to each other? Explain why or why not.**

Solution:

No, the songs cannot be perfectly orthogonal to each other because this would imply that the songs are linearly independent. However, since the songs have a length of 40, we could then only have at most 40 songs. However, we have 100 songs, so they cannot be perfectly orthogonal to each other.

- (b) (3 points) Consider the case where only one device is transmitting. In order to identify this single transmitting device, **how many inner products do you need to calculate? Describe what they are.**

Solution:

You would need to calculate $100 \cdot 40 = 4000$ inner products. For each of the 100 songs, you would need to cross-correlate it with the received signal, i.e., calculate the inner product once for each of the 40 possible shifts. Therefore, you would need $100 \cdot 40 = 4000$ inner product calculations.

PRINT your name and student ID: _____

In the next three parts, you may be writing pseudocode. To do this, you may do the following:

- You may implement helper functions and use them repeatedly in your solution.
- You may define your solution from one part as a function and use that function in a later part.
- In your pseudocode, you may use iteration (for and while loops).
- Acceptable pseudocode formats:

```

corrVec = corr(v1, v2)           corrVec is corr(v1, v2)
peakId, peakVal = pd(corrVec)   peakId and peakVal returned from pd(corrVec)
bhat = dot(A, lsq(A, b))        bhat = A dot lsq(A, b)
for i in range(10):             for i in (0, 1, ..., 9):
    vecaug(v, i)                 vecaug(v, i)

```

- The functions that you may use:

Name	Inputs	Outputs	Function Description
Correlation corr	\vec{v}_1 and \vec{v}_2	$\mathbf{C}_{\vec{v}_2 \vec{v}_1}$	Calculates the circular correlation of the \vec{v}_1 with \vec{v}_2
Peak detection pd	\vec{v}	$i \leftarrow$ peak index $v[i] \leftarrow$ value of \vec{v} at index i	Outputs the index at which peak occurs as well as the peak value
Circular rotation circrot	\vec{v}, i	$\vec{v}^{(i)}$	Outputs the vector circulated rotated by i
Vector subtraction sub	\vec{v}_1 and \vec{v}_2	$\vec{v}_1 - \vec{v}_2$	Subtracts two vectors in the given order
Matrix multiplication dot	\mathbf{A} and \vec{v}	$\mathbf{A}\vec{v}$	Matrix vector multiplication
Least squares lsq	\mathbf{A} and \vec{b}	$\vec{x} = (\mathbf{A}^T \mathbf{A})^{-1} \mathbf{A}^T \vec{b}$	Least squares solution to the equation $\mathbf{A}\vec{x} = \vec{b}$
Create vector vec	a_0, a_1, \dots, a_{N-1}	$\vec{a} = \begin{bmatrix} a_0 \\ a_1 \\ \vdots \\ a_{N-1} \end{bmatrix}$	Creates a vector of length N
Vector augment vecaug	\vec{v} and i	$\begin{bmatrix} \\ \vec{v} \\ \\ i \end{bmatrix}$	Augments the vector \vec{v} with the new element i
Set augment setaug	S and i	$S = S \cup \{i\}$	Augments the set S with the new element i
Matrix augment mataug	\mathbf{A} and \vec{v}	$\left[\mathbf{A} \mid \vec{v} \right]$	Augments matrix \mathbf{A} with column vector \vec{v}
Threshold reached thres	\vec{v} and threshold k	$I = \mathbb{I}\{\ \vec{v}\ > k\}$	Outputs 1 if norm of the vector is greater than the threshold k and 0 otherwise

Table 12.1: Table of functions available.

PRINT your name and student ID: _____

- (c) (5 points) Suppose that $m = 1$, i.e., you know that at most one device is transmitting at any given time. **Write pseudocode using the functions given to you that will output which of the devices was transmitting and an estimate for what it was transmitting.** The inputs to your algorithm are the received signal vector \vec{r} and the dictionary of songs $\mathcal{S} = \{\vec{s}_0, \vec{s}_1, \dots, \vec{s}_{99}\}$. **The outputs of your algorithm are the index of the transmitting device i , the shift that the corresponding song experienced N_i , and the message estimate \hat{a}_i .**

Solution:

```
peaks = vec([])
shifts = vec([])
for i in range(100):
    shift, peak = pd(corr( $\vec{r}$ ,  $\vec{s}_i$ ))
    vecaug(peaks, peak)
    vecaug(shifts, shift)
index, message = pd(peaks)
shift = shifts[index]
return index, shift, message
```

- (d) (3 points) Suppose that $m = 4$, i.e., you know that at most four devices are transmitting at any given time. However, you are only interested in the ‘loudest’ device, i.e., the device with the largest $\|a_i\|$. **Would the pseudocode from part (c) return the best estimate for the ‘loudest’ device? Explain why or why not.**

Solution:

No, not necessarily. Because of interference from other devices’ songs, the message estimates may be corrupted by the other devices’ songs. Additionally, we might not even find the right device let alone the estimate of the message since the pseudocode from part (c) might not necessarily output the devices from the ‘loudest’ device to the ‘quietest’ one.

PRINT your name and student ID: _____

- (e) (7 points) Let $m = 4$ and suppose that you are interested in the two ‘loudest’ devices. **Write pseudocode using the functions given to you that will output the indices of the two ‘loudest’ devices and estimates what the two ‘loudest’ devices were transmitting.** The inputs to your algorithm are the received signal vector \vec{r} and the dictionary of songs $\mathcal{S} = \{\vec{s}_0, \vec{s}_1, \dots, \vec{s}_{99}\}$. **The outputs of your algorithm are the indices of the two loudest devices $\{i_1, i_2\}$, the shifts that the respective songs experienced $\{N_{i_1}, N_{i_2}\}$, and the message estimates $\{\hat{a}_{i_1}, \hat{a}_{i_2}\}$.**

Solution:

We define the function from part (c) as `find_song`.

```
A = mat([])
indices = vec([])
shifts = vec([])
j = 0
b =  $\vec{r}$ 
while j < 4 and thres(b, k):
    index, shift, message = find_song(b,  $\mathcal{S}$ )
    mataug(A, circrot( $\vec{s}_{\text{index}}$ , shift))
    vecaug(indices, index)
    vecaug(shifts, shift)
    x = lsq(A,  $\vec{r}$ )
    b = sub( $\vec{r}$ , dot(A, x))
    j = j + 1
index1 = pd(x)[0] # index of largest element
x_temp = vec(x) # create a copy of x to find second largest element
x_temp[index1] = 0
index2 = pd(x_temp)[0] # index of second largest element
return [indices[index1], indices[index2]],
        [shifts[index1], shifts[index2]],
        [x[index1], x[index2]]
```

PRINT your name and student ID: _____

Extra page for scratchwork.

If you want any work on this page to be graded, please refer to this page on the problem's main page.