

## 19.1 Golden Rules Revisited

Recall for an ideal op amp, the "golden rules" are

- (1)  $I_+ = I_- = 0$ . No current can flow into the positive or negative input terminal. **Note that this rule holds regardless of whether there is negative feedback or not.**
- (2) For a circuit with negative feedback,  $U_+ = U_-$ . **This rule only holds when there is negative feedback.**

$U_+ = U_-$  means that the control voltage  $v_c = U_+ - U_-$  is 0V for an op-amp. In order to understand how  $v_{out}$  can be non-zero for  $v_c = 0$ , let's review the block diagram of an op amp in negative feedback.

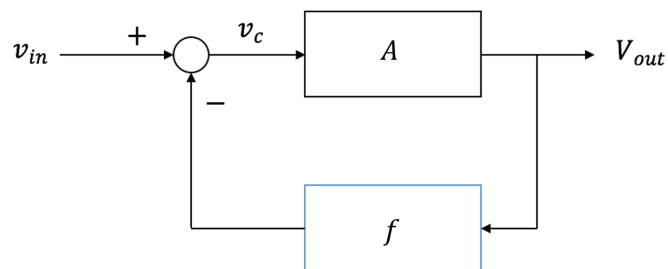

We have negative feedback gain  $f$ . For an op-amp in negative feedback, we have

$$v_{in} - f \cdot v_{out} = v_c. \quad (1)$$

We know  $v_{out} = A \cdot v_c$  and we can derive:

$$v_{out} = \frac{A}{1 + A \cdot f} v_{in}. \quad (2)$$

When  $v_{in} = 0V$ ,  $v_c = 0V$ . Recall mathematically,  $\lim_{x \rightarrow \infty} k \cdot x \cdot \frac{1}{x} = k$  even though  $\lim_{x \rightarrow \infty} \frac{1}{x} = 0$ . Similarly, for an ideal op-amp,  $v_{out}$  can be non-zero even if  $v_c = 0$  given  $A = \infty$ .

## 19.2 Signals vs. Supply Voltages

As we saw in the last note (and will continue to explore here), op-amps allow us to perform mathematical operations on the input voltages. In real systems, these input voltages are typically small signals that we have measured, for example, changes in light intensity or electrical brain activity read from an EEG. Although these signals are voltages, they are different from the supply voltages of an op-amp because they are typically much smaller and they change over time.

To distinguish, we will use the following symbol to represent time-varying voltage signals:

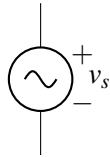

We will continue to use our standard voltage source to represent static voltages that are used as power supplies (such as those connected to  $V_{SS}$  and  $V_{DD}$  of an op-amp). Voltage *signals* generally should not be used to power an op-amp since this would create time-varying behavior of the op amp.

## 19.3 Inverting Amplifier & Negative Feedback

Now let's practice using the golden rules to analyze the circuit we saw earlier:

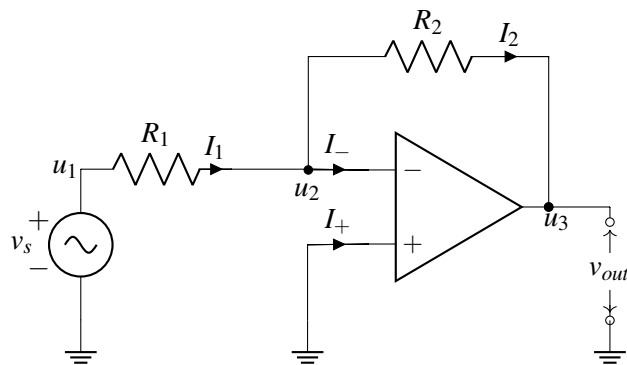

Let's assume that this circuit is in negative feedback so that we can use golden rule #2, after analyzing the circuit we will show how to check if a circuit is indeed in negative feedback.

We know that by applying KCL, we have

$$I_1 = I_2 + I_- \quad (3)$$

Using golden rules # 1, we have

$$I_- = 0. \quad (4)$$

Thus,  $I_1 = I_2$ . Using golden rules # 2, we have

$$u_- = u_+ = 0. \quad (5)$$

The second equation indicates  $u_2 = 0$ .

Using Ohm's law, we have

$$u_1 - u_2 = I_1 R_1. \quad (6)$$

$$u_2 - u_3 = I_2 R_2. \quad (7)$$

After solving the equations, we get

$$v_{out} = -\frac{R_2}{R_1} v_{in}. \quad (8)$$

This circuit is known as "inverting amplifier". It is called "inverting" because it amplifies  $v_{in}$  by some negative factor  $-\frac{R_2}{R_1}$ .

## 19.4 Checking for Negative Feedback

We have used golden rule #2 to simplify circuit analysis, now we will show how to check if a circuit is in negative feedback:

- **Step 1:** Zero out all **independent** sources. We will zero them out like we did in Thevenin-Norton Equivalencies (Voltage sources become wires and current sources become open circuits).
- **Step 2:** "Dink" the output, check if the feedback coming from the circuit as a result of "dinking" the output has the opposite direction of "dinking". If the feedback coming from the circuit is in the opposite direction as "dinking" the output, then the circuit is in negative feedback. If not, the circuit is in positive feedback or zero feedback.

Let's use the rules to check some example circuits.

### Example circuit 1

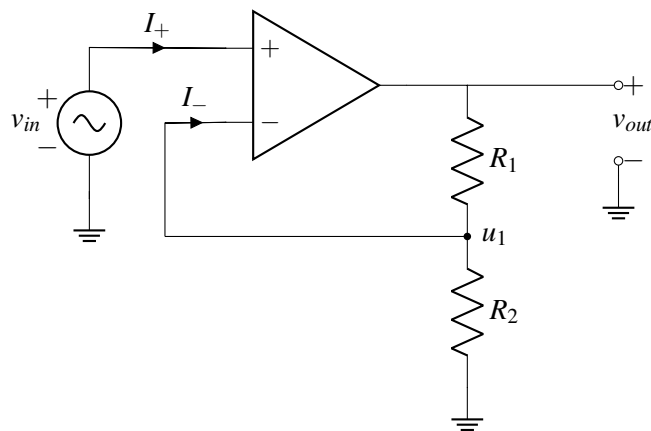

**Step 1: Zero-out all independent sources.** We can zero-out the independent source  $v_{in}$  in the circuit, and the circuit diagram becomes:

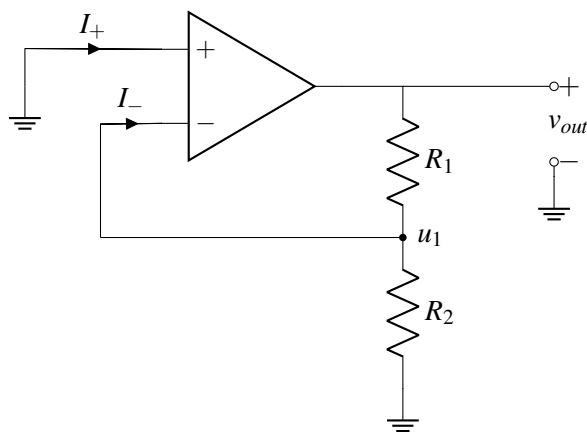

**Step 2: "Dink"  $v_{out}$ .** If we increase  $v_{out}$ , we know  $u_1$  is going to increase because  $R_1$  and  $R_2$  form a voltage divider circuit.  $u_1$  is connected to  $u_-$ , so  $u_-$  increases, therefore  $v_{in} = u_+ - u_-$  decreases, and thus  $v_{out}$  decreases. So the feedback from the circuit is in the opposite direction, this circuit is in negative feedback.

**Example circuit 2**

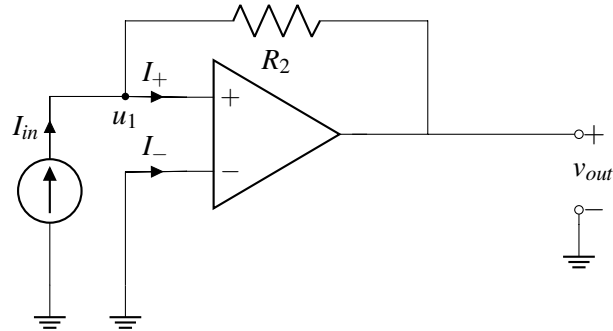

**Step 1: Zero out all independent sources.**

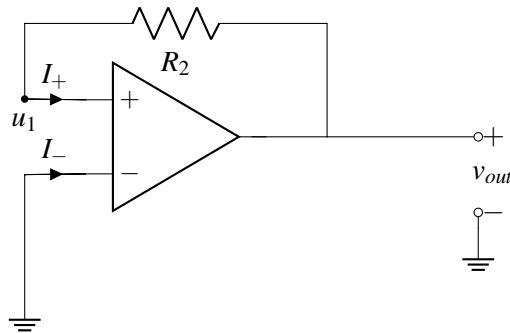

**Step 2: "Dink"  $v_{out}$ .** If we increase  $v_{out}$ , we know  $u_1$  is going to increase because  $u_1 = v_{out}$ .  $u_1$  is connected to  $u_+$ , so  $u_+$  increases, therefore  $v_{in} = u_+ - u_-$  increases, and thus  $v_{out}$  increases. So the feedback from the circuit is in the same direction, this circuit is in positive feedback.

**Example circuit 3**

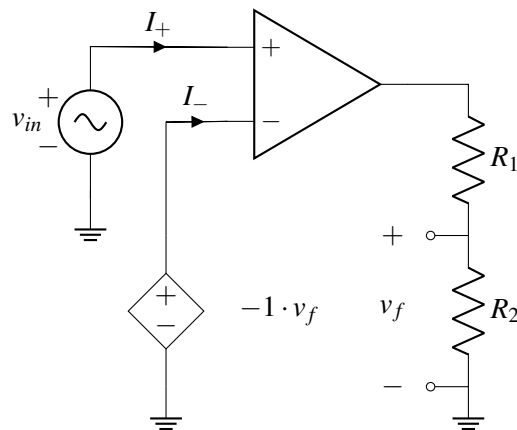

**Step 1: Zero out all independent sources.** We cannot zero out controlled voltage source  $-1 \cdot v_f$  because this is not an independent voltage source.

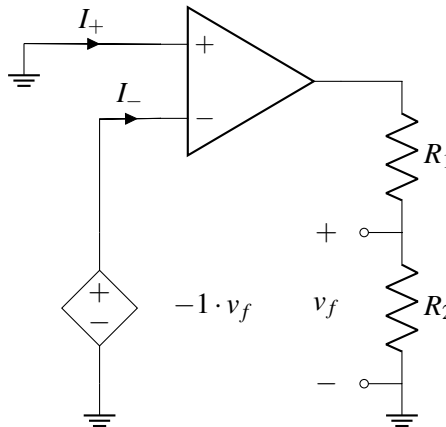

**Step 2: "Dink"  $v_{out}$ .** If we increase  $v_{out}$ ,  $v_f$  increases which then decreases  $v_- = -1 \cdot v_f$ , which then increases  $v_{in} = u_+ - u_-$ , thus  $v_{out}$  increases. The circuit response to the increase in  $v_{out}$  is in the same direction as we "dinked"  $v_{out}$ . So this circuit is not in negative feedback.

## 19.5 Non-inverting & Inverting Amplifiers

There are two important categories of amplifier circuits that you should be familiar with, they are non-inverting amplifier and inverting amplifier:

- **Non-inverting Amplifier**

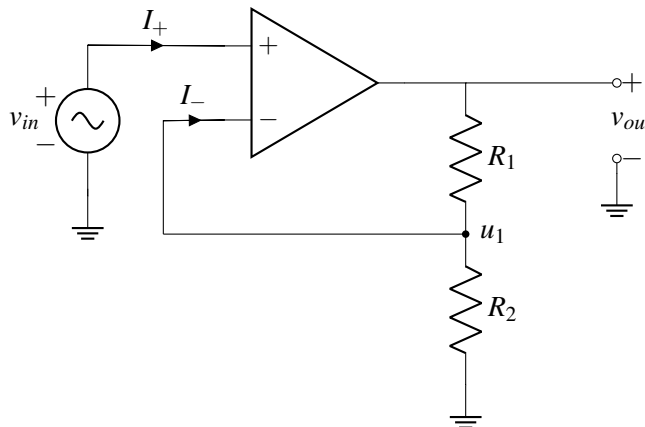

For the non-inverting amplifier circuit, we have

$$v_{out} = \left(1 + \frac{R_1}{R_2}\right) \cdot v_{in}. \quad (9)$$

- **Inverting Amplifier**

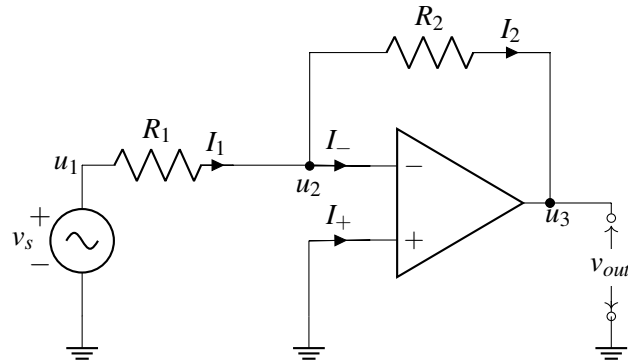

For the inverting amplifier circuit, we have

$$v_{out} = -\frac{R_2}{R_1} \cdot v_{in}. \quad (10)$$

## 19.6 Artificial Neuron Example

Neurons in our brain are interconnected. The output of a single neuron is dependent on inputs from several other neurons. We can represent this idea with vector-vector multiplication, in which the output is a linear combination of several inputs.

$$\begin{bmatrix} a_1 & a_2 \end{bmatrix} \cdot \begin{bmatrix} x_1 \\ x_2 \end{bmatrix} = a_1 \cdot x_1 + a_2 \cdot x_2 \quad (11)$$

To build an artificial neuron, we use the following circuit model:

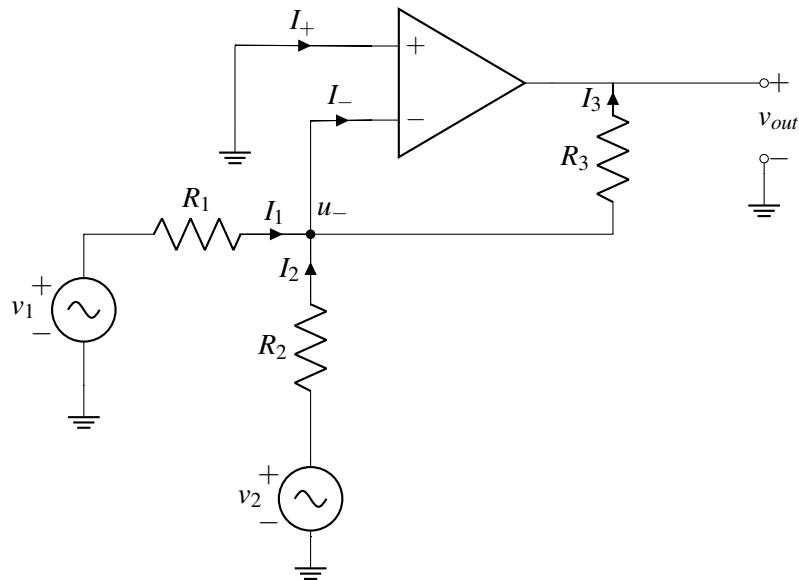

Let's analyze this circuit. First, let's apply the first golden rule,  $I_- = I_+ = 0$ . Applying KCL at the node labelled  $u_-$ , we have

$$I_1 + I_2 = I_- + I_3 = 0 + I_3 = I_3. \quad (12)$$

Hence, we have

$$I_1 + I_2 = I_3. \quad (13)$$

Now by the second golden rule and the fact that the positive input terminal is connected to ground (which implies negative feedback), we have

$$u_+ = u_- = 0. \quad (14)$$

Applying Ohm's law at each of the three resistors, we have

$$I_1 = \frac{v_1 - u_-}{R_1} = \frac{v_1}{R_1} \quad (15)$$

$$I_2 = \frac{v_2 - u_-}{R_2} = \frac{v_2}{R_2} \quad (16)$$

$$I_3 = \frac{u_- - v_{out}}{R_3} = -\frac{v_{out}}{R_3} \quad (17)$$

$$(18)$$

Plugging in the above result to the KCL equation  $I_1 + I_2 = I_3$  derived previously, we have

$$\frac{v_1}{R_1} + \frac{v_2}{R_2} = -\frac{v_{out}}{R_3}. \quad (19)$$

Multiplying both sides by  $-R_3$ , we have

$$v_{out} = -\frac{R_3}{R_1}v_1 - \frac{R_3}{R_2}v_2, \quad (20)$$

relating the final output with the two inputs  $v_1$  and  $v_2$ , which are  $x_1$  and  $x_2$  in equation (11). Now,  $a_1 = \frac{R_3}{R_1}$ ,  $a_2 = \frac{R_3}{R_2}$ . This circuit is named "inverting summing amplifier" — since  $R_1, R_2, R_3$  are resistors and all have positive values, the coefficients  $a_1$  and  $a_2$  are all negative. How do we make  $a_1$  and  $a_2$  positive instead? By adding another inverter amplifier circuit at  $v_{out}$ , we can get positive coefficients.

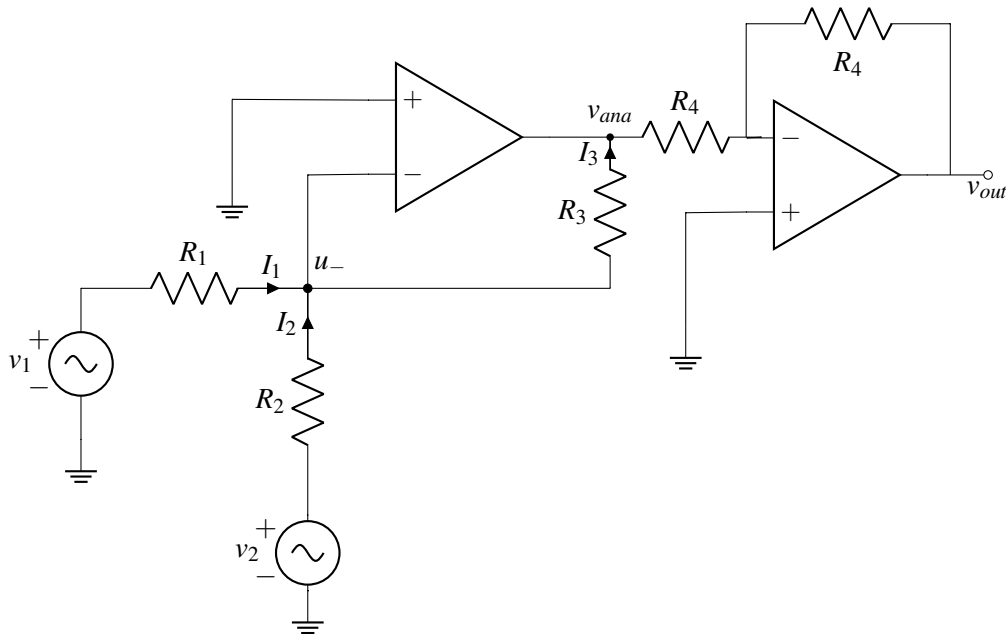

Now we have

$$v_{ana} = -\frac{R_3}{R_1}v_1 - \frac{R_3}{R_2}v_2. \quad (21)$$

For the inverting amplifier just added

$$v_{out} = -\frac{R_4}{R_4}v_{ana}. \quad (22)$$

Hence,

$$v_{out} = \frac{R_3}{R_1}v_1 + \frac{R_3}{R_2}v_2. \quad (23)$$

Now we have positive coefficients  $a_1 = \frac{R_3}{R_1}$ ,  $a_2 = \frac{R_3}{R_2}$ .

## 19.7 Loading and Buffering

Consider the following *unity gain buffer* (we'll see why it's called that shortly).

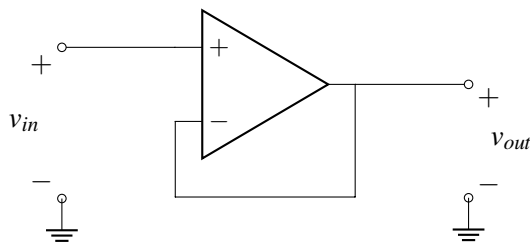

To analyze this circuit, we first notice that  $u_+ = v_{in}$  and  $u_- = v_{out}$ . We apply the second golden rule,  $u_+ = u_-$ , which tells us

$$v_{in} = v_{out}.$$

The input and output voltages are the same! (This is where the term *unity gain* comes from). Does that mean that this circuit is useless? No! To see why, let's look back at the DAC-speaker example from the last note. Recall that we want to drive our speaker using the output voltage from our DAC (let's suppose that no amplification is necessary). We model our DAC with its thevenin equivalent circuit where  $R_{TH} = 1k\Omega$ , and we model the speaker as an  $8\Omega$  resistor connected to ground.

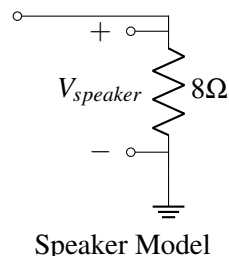
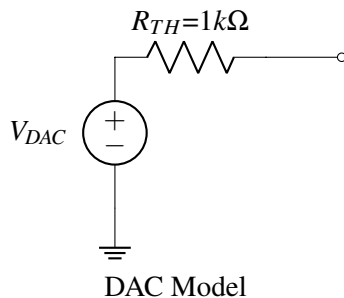



In this example, we'd like  $V_{speaker} = V_{DAC}$ , so that the DAC output is directly played on the speaker. We try connecting the DAC and speaker together directly:

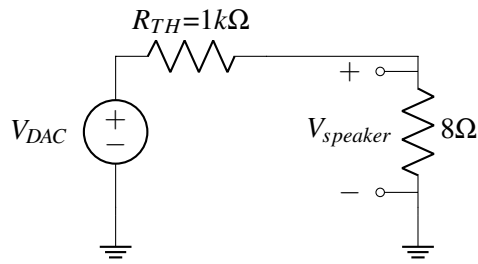

Using the voltage divider equation, we calculate that

$$V_{speaker} = \frac{8\Omega}{1000\Omega + 8\Omega} V_{DAC} = 0.0079 V_{DAC}$$

which is much smaller than we'd like.

The speaker has a small resistance, so it draws a lot of current causing a large voltage drop over  $R_{TH}$ , much larger than when the speaker was not present. This effect is called **loading**. Loading effects make it much harder to design circuits because they mean that the DAC will behave differently depending on what it's connected to. Specifically, if the circuit afterwards draws current through  $R_{TH}$ , then the output voltage drops. Furthermore, the amount it drops depends on the speaker's resistance — but we don't want to have to redesign our circuit every time we buy a new speaker!

This is where our unity gain buffer from before can help. Rather than connecting the DAC and speaker directly, we include the buffer in between as follows:

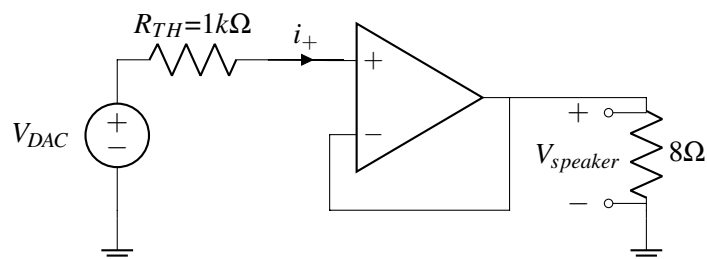

From the first golden rule, we know that  $i_+ = 0$ . This means there is no current through  $R_{TH}$ , and therefore no voltage drop across the resistor. In other words, the op-amp does not load the DAC since it has infinite internal resistance (remember that we model the input terminals as floating nodes)! Since there is no voltage drop over  $R_{TH}$ , we know that  $u_+ = V_{DAC}$ . Combing this with our previous analysis of the buffer, we see that  $V_{DAC} = V_{speaker}$ , as desired.

Buffers are a powerful tool because they allow us to split circuits into blocks that we can analyze separately and then combine later. When circuit blocks behave the same way regardless of what they're connected to, we don't need to worry about what's inside, making it much easier to design complex circuits.

## 19.8 Practice Problems

These practice problems are also available in an interactive form on the course website.

1. Is the following amplifier in an inverting or a non-inverting configuration?

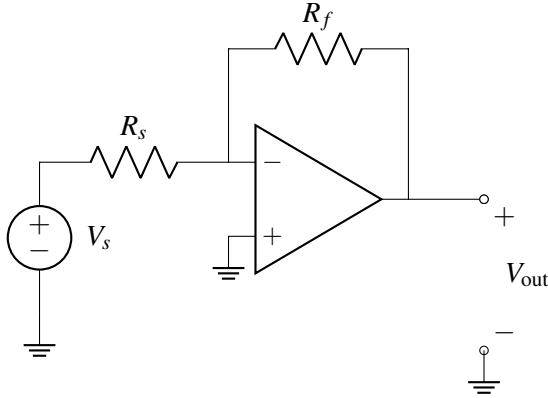

2. In the circuit above, if  $R_s = 50\ \Omega$ ,  $R_f = 100\ \Omega$ , and  $V_s = 2\ \text{V}$ , what is the value of  $V_{out}$ ?
3. Is the following op-amp in negative feedback?

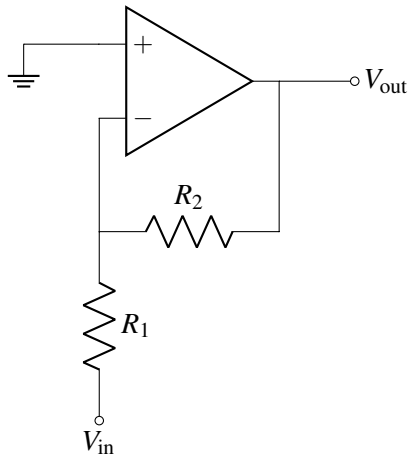

4. For the circuit above, find  $V_{out}$  in terms of  $V_{in}$ .
5. True or False: An inverting amplifier can have any negative gain (for positive resistor values).

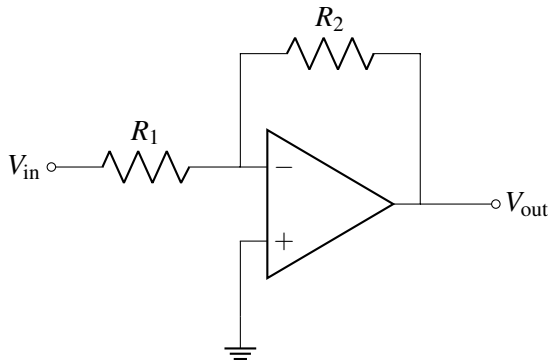

6. True or False: A non-inverting amplifier can have any non-negative gain (for positive resistor values).

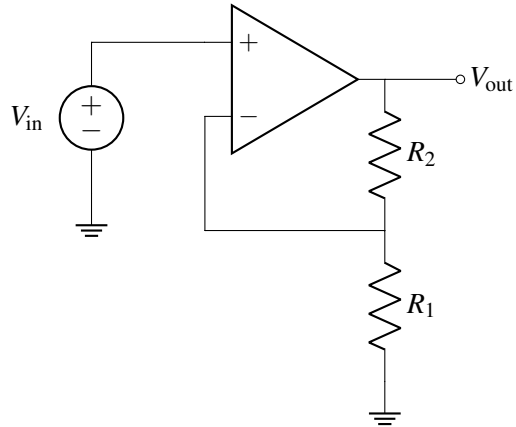

7. If we placed a buffer, which is an op-amp in negative feedback that has a gain of 1, between two subcircuits, would it be the same as connecting the subcircuits with a wire?

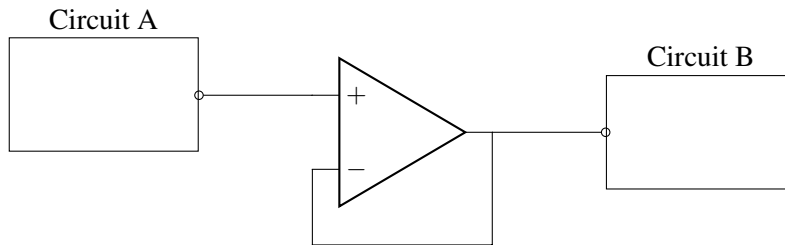

- (a) Yes, because the buffer isn't changing the value between the subcircuits.  
(b) No, because the buffer does not change the voltage of the circuit it is connected to.