

11.1 Node Voltage Analysis

In this course, we will learn how to take a real world system and build a circuit diagram that models the behavior of that system, and we will design our own circuits for specific real world tasks. In this note, however, we will assume that we already have an accurate circuit diagram, and will learn how to analyze the circuit.

For a given circuit, we would like to find all of the voltages and currents—sometimes we call this “solving” the circuit. Specifically, once you have or are given an accurate circuit diagram, you should be able to follow the given analysis algorithm to “solve” the circuit (i.e., compute all of the voltages and currents) correctly. Circuits are deterministic; if you follow the steps accurately and completely, the math will work.

Definition 11.1 (Node Voltage Analysis): **Node Voltage Analysis** is a procedure for analyzing and solving a circuit using KCL equations to derive its node voltages.

To apply Node Voltage Analysis, we will need to properly identify both the **nodes** and **branches** of the circuit diagram.

Definition 11.2 (Node): A circuit **node** describes a region of the circuit which is *equipotential* (i.e., at the same/equivalent voltage throughout). Alternatively, it is a place where two or more circuit elements meet.

Definition 11.3 (Branch): A circuit **branch** describes a circuit path with equal current throughout. A branch can contain one or more circuit elements, and often connects two nodes.

Consider an example using the following diagram, which consists of three elements: a voltage source and two resistors.

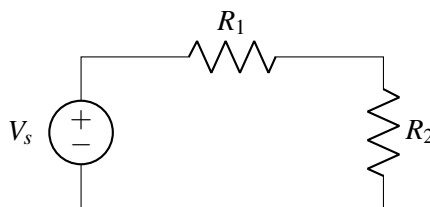

For the sake of clarity, after each step of the analysis algorithm we show what the current circuit diagram looks like. When you perform the algorithm on your own, however, *you do not need to redraw the circuit each time*; instead you can simply label/annotate a single diagram.

Step 1: Pick a node and label it as $u = 0$ V (“reference”), meaning that we will measure all of the other node voltages in the circuit relative to this point. Any node can be the reference node, but conventionally

its the negative terminal of a voltage source. On the schematic we can also use a **ground symbol** to denote the reference node.

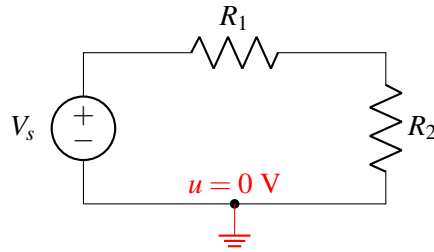

Step 2: Label all remaining nodes as some “ u_i ”, representing the voltage at each node relative to the zero/reference node.

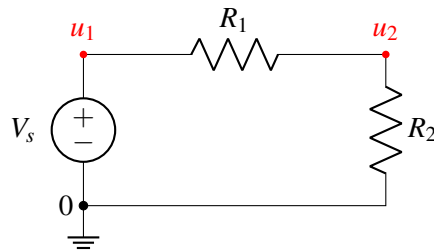

Step 3: Label the current through every element in the circuit “ i_n ” so that every element has a current label. The direction of the arrow indicates which direction of current flow you are considering to be positive. At this stage of the algorithm, you can pick the direction of all the current arrows *arbitrarily*. As long as you are consistent with this choice and follow the rules described in the rest of this algorithm, the math will work out correctly.

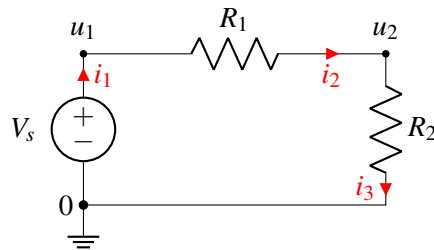

Note that we only label the current once for each element—for example, we can label i_3 as the current leaving the resistor (as is done in the diagram) *or* we can label it as the the current entering the resistor. These are equivalent because KCL also holds within the element itself—i.e., the current entering an element must be equal to the current exiting that same element.

Step 4: Add $+/-$ labels on each element to indicate positive/negative voltage, following **passive sign convention** (defined below). These labels will indicate the direction with which voltage will be measured across that element.

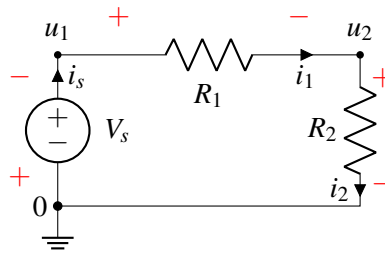

Definition 11.4 (Passive Sign Convention): The **passive sign convention** dictates that positive current should *enter* the positive voltage terminal and *exit* the negative voltage terminal of an element. Below is an example for a resistor:

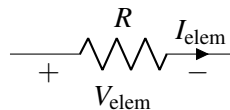

Labeling using passive sign convention ensures the values of voltage and current *as labeled* will either both be positive ($V_{elem} > 0$ and $I_{elem} > 0$) or both be negative ($V_{elem} < 0$ and $I_{elem} < 0$) for *passive* circuit elements. When we discuss the electrical quantity **power** later in Module #2, we will define the term “passive”.

In the above circuit example, it might seem peculiar that the voltage labeling on the voltage source is opposite to its ‘internal’ voltage polarity. This results from: 1) the arbitrary direction we picked for current i_1 and 2) following passive sign convention for voltage labeling. Since we consistently followed the above steps, this does not effect our final solution of node voltages and element currents, as we shall see.

Note: As long as your labeling is consistent, the solution to the circuit voltages and currents will be correct with respect to the way you labeled them.

Step 5: Identify all unknowns. Then reduce this number by recognizing redundant currents/voltages.

At this stage in the circuit analysis algorithm, we find that there are several **unknowns** labeled on our circuit. These are the branch currents i_s , i_1 , and i_2 and the node voltages u_1 and u_2 .

We can reduce the number of unknown variables by making some plain substitutions.

(a) Simplify node voltages:

We can apply the known voltage of the voltage source to reduce the number of unknown node voltages. For this example,

$$u_1 - 0 = V_s$$

thus the node voltage $u_1 = V_s$ is known.

(b) Simplify element currents in the same branch:

If a node connects only two elements, then applying KCL at this node reveals the currents through both elements are equivalent. In this example,

$$i_1 = i_s$$

$$i_2 = i_s$$

and so the circuit currents can be effectively expressed with a single unknown current i_s .

Utilizing the current of a current source can also simplify the unknown element currents.

Step 6a: Set up a system of linear equations using KCL and I-V relationships. Write a KCL equation at each node with unknown voltage.

Begin by writing KCL equations for every node in the circuit.

$$i_s - i_1 = 0$$

$$i_1 - i_2 = 0$$

$$i_2 - i_s = 0$$

Notice the last equation we get is linearly dependent with the first two—you can see this by adding the first two equations to each other and multiplying the entire result by -1. We will therefore omit this equation derived from KCL at the reference node.

In general, if you use KCL at every node, you will get one linearly dependent equation, and so you can typically simply skip one node; *skipping the node that has been labeled as **reference** is the conventional choice.*

Step 6b: Use the I-V relationships of each element and express the voltage across each circuit element as a difference of node voltages.

We know that the difference in potentials across the voltage source must be its voltage, V_s . We also know that the voltage across the resistor is equal to the current times the resistance, from Ohm's Law (i.e., $V = I \cdot R$). Note that the polarity of Ohm's Law depends on correctly applying **passive sign convention**. Thus, we have the following equations:

$$V_{R_1} = i_1 R_1$$

$$V_{R_2} = i_2 R_2$$

Next, express the voltage across each circuit element as a difference of node voltages.

$$V_{R_1} = u_1 - u_2$$

$$V_{R_2} = u_2 - 0$$

In this way we directly relate the element I-V characteristics and the node voltages.

Step 7: Simplify your equations and solve. Be sure to incorporate the reduction in unknowns from Step 5 (i.e., $u_1 = V_s$, $i_1 = i_s$, $i_2 = i_s$.)

The final equations in terms of the two unknowns u_2 and i_s are

$$V_s - u_2 = i_s R_1$$

$$u_2 = i_s R_2$$

To solve, one can use substitution to find expressions for the unknowns, u_2 and i_s ,

$$u_2 = \frac{R_2}{R_1 + R_2} V_s \quad \text{and} \quad i_s = \frac{1}{R_1 + R_2} V_s$$

If there are too many remaining unknowns when arriving at Step 7, then we can alternatively use our linear algebra techniques (e.g., Gaussian Elimination) from Module #1.

$$\mathbf{A}\vec{x} = \vec{b} \quad \longrightarrow \quad \begin{bmatrix} 1 & R_1 \\ 1 & -R_2 \end{bmatrix} \begin{bmatrix} u_2 \\ i_s \end{bmatrix} = \begin{bmatrix} V_s \\ 0 \end{bmatrix} \quad \longrightarrow \quad \begin{bmatrix} u_2 \\ i_s \end{bmatrix} = \begin{bmatrix} \frac{R_2}{R_1 + R_2} V_s \\ \frac{1}{R_1 + R_2} V_s \end{bmatrix}$$

Check:

Applying KVL to the loop in this circuit, the applied voltage source V_s must be divided between the two resistors: $V_s = V_{R_1} + V_{R_2}$. The proportion of voltage drop across each resistor depends on the relationship between R_1 and R_2 . This **voltage divider** circuit is discussed further in Note 12.

11.1.1 Summary of Node Voltage Analysis Procedure

Here is a summary of the steps for **Node Voltage Analysis**:

- Step 1:** Pick a reference **node** and label it as $u = 0$ V, meaning that we will measure all of the nodal voltages in the rest of the circuit relative to this node.
- Step 2:** Label all remaining **nodes** as some “ u_i ”, representing the voltage at each node relative to the reference node.
- Step 3:** Label the current through every element as “ i_n ”.
- Step 4:** Add $+/-$ labels (indicating direction of voltage measurement) on each circuit element by following the passive sign convention.
- Step 5:** Identify all unknowns. Then reduce this number by recognizing redundant currents/voltages.
- Step 6:** Set up a system of linear equations using KCL and I-V relationships. Write a KCL equation at each node with unknown voltage. Express voltage across each circuit element as a difference of node voltages. Express I-V relationships (e.g., Ohm’s law for resistors) of each circuit element.
- Step 7:** Solve system of linear equations.

11.2 Node Voltage Example

Example 11.1 (Node Voltage): Find all voltages (and currents) in the following electronic circuit. The circuit parameters are as follows: $R_1 = 1\ \Omega$, $R_2 = 2\ \Omega$, $R_3 = 3\ \Omega$, $R_4 = 4\ \Omega$, $V_s = 1$ V, and $I_s = 0.5$ A.

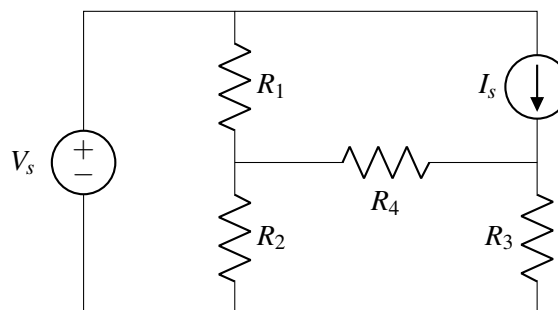

Step 1: Choose reference node

Select a reference node. Any node can be chosen for this purpose. In this example, we choose the node at the bottom of the circuit diagram.

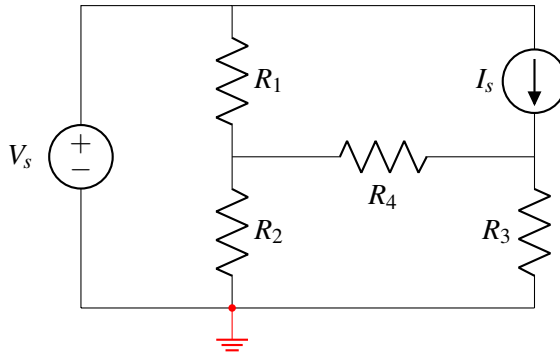

Step 2: Label all nodes

After choosing the reference node, label all the other nodes in the circuit. In this example there are three unknown nodes: u_1 , u_2 and u_3 .

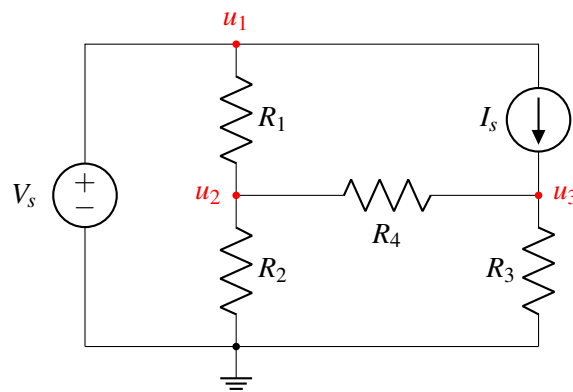

Step 3: Label currents through circuit elements

The directions are arbitrary (top to bottom, bottom to top, it won't matter, but stick with your choice in subsequent steps).

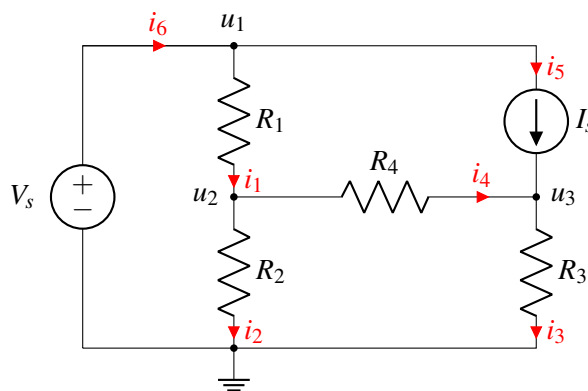

Step 4: Label element potentials based on passive sign convention.

The element voltage across I_s is not marked in the example since it will not be needed in the calculations below. The same is true for the voltage across the voltage source (we already know it!). But there is no harm in marking those, too.

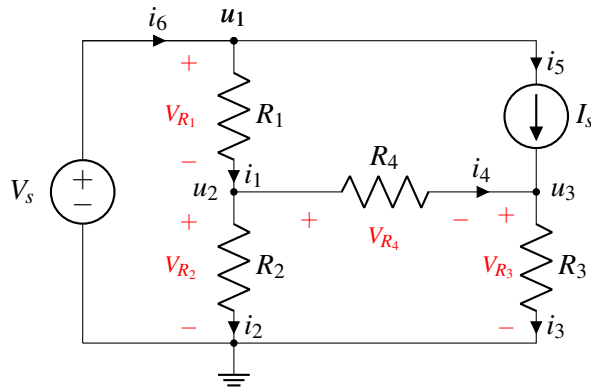

Step 5: Identify and reduce the number of unknowns if possible.

The unknowns are all of the node voltages (except the reference node): u_1 , u_2 , u_3 ; and the branch currents: i_1 , i_2 , i_3 , i_4 , i_5 .

From inspection, the node voltage $u_1 = V_s$ as well as the branch current $i_5 = I_s$ are known and can thus be reduced.

Step 6a: KCL Equations

Write KCL equations for all nodes with unknown voltages: u_2 and u_3 (this excludes the reference node).

At node u_1 , we know from KCL that the sum of all currents entering the node equals sum of all currents exiting:

$$i_6 - i_1 - i_5 = 0 \quad \longrightarrow \quad i_6 - i_1 = I_s$$

Similarly at node u_2 we get:

$$i_1 - i_2 - i_4 = 0$$

Finally, for node u_3 :

$$i_5 + i_4 - i_3 = 0$$

Step 6b: Element I-V relationships

Find expressions for all element voltages in terms of the currents and element characteristics (e.g. Ohm's law) for all circuit elements except the current source. In this example there are six element characteristics: R_1 , R_2 , R_3 , R_4 , V_s , and I_s . We can also represent the element voltages as differences of the node voltages u_1 , u_2 , and u_3 .

$$R_1 i_1 = V_{R_1} = u_1 - u_2 = V_s - u_2$$

$$R_2 i_2 = V_{R_2} = u_2$$

$$R_3 i_3 = V_{R_3} = u_3$$

$$R_4 i_4 = V_{R_4} = u_2 - u_3$$

Now we have seven unique equations (including the three KCL equations in Step 5) and seven unknowns: u_2 , u_3 , i_1 , i_2 , i_3 , i_4 , and i_6 .

Step 7: Solve

We will consider two methods for solving this system.

- (a) *Method 1*: The first method focuses on deriving only the unknown node voltages using substitution and/or linear algebra. After the node voltages are found, the branch currents can be independently derived as needed.
- (b) *Method 2*: The second method is the matrix-oriented approach where all of the node voltages and branch currents are solved simultaneously using linear algebra.

It will often be much easier (especially when solving problems by hand) to perform *Method 1*. This is because often a circuit is considered ‘solved’ once all of the node voltages are known. This is the practical utility of **node voltages** and **Node Voltage Analysis**.

Method 1: This method involves expressing a system of KCL equations in terms of only the node voltages and known quantities (e.g., R_1, R_2, R_3, R_4, V_s , and I_s).

Substitute the derived element expressions into the KCL equations (from Step 5) at circuit nodes with unknown voltages (in this case u_2 and u_3). Also substitute known variables such as $u_1 = V_s$ and $i_5 = I_s$.

$$\begin{aligned} i_1 - i_2 - i_4 = 0 &\implies \frac{V_s - u_2}{R_1} - \frac{u_2}{R_2} - \frac{u_2 - u_3}{R_4} = 0 \\ i_5 + i_4 - i_3 = 0 &\implies I_s + \frac{u_2 - u_3}{R_4} - \frac{u_3}{R_3} = 0 \end{aligned}$$

Now we have a system of two linearly independent equations and two unknowns: u_2 and u_3 . Further substitution can be used, but linear algebra can also be a useful tool here. Let us first reorganize these equations by grouping the unknowns (u_2 and u_3) on the left side and the known terms on the right:

$$\begin{aligned} u_2 \cdot \left(\frac{1}{R_1} + \frac{1}{R_2} + \frac{1}{R_4} \right) R_1 + u_3 \cdot \left(-\frac{R_1}{R_4} \right) &= V_s \\ u_2 \cdot \left(-\frac{1}{R_4} \right) + u_3 \cdot \left(\frac{1}{R_3} + \frac{1}{R_4} \right) &= I_s \end{aligned}$$

Then cast the equations into a matrix-vector representation:

$$\mathbf{A}\vec{x} = \vec{b} \quad \longrightarrow \quad \begin{bmatrix} \left(\frac{1}{R_1} + \frac{1}{R_2} + \frac{1}{R_4} \right) R_1 & -\frac{R_1}{R_4} \\ -\frac{1}{R_4} & \frac{1}{R_3} + \frac{1}{R_4} \end{bmatrix} \begin{bmatrix} u_2 \\ u_3 \end{bmatrix} = \begin{bmatrix} V_s \\ I_s \end{bmatrix}$$

With the given circuit parameters: $R_1 = 1 \Omega, R_2 = 2 \Omega, R_3 = 3 \Omega, R_4 = 4 \Omega, V_s = 1 \text{ V}, I_s = 0.5 \text{ A}$; this provides enough information for us to populate matrix \mathbf{A} and vector \vec{b} and solve for the unknowns. Finally compute the solution using Gaussian Elimination (or let the computer do the work, here using sympy):

```

from sympy import *
init_printing(use_unicode=True)

R1, R2, R3, R4 = symbols('R1 R2 R3 R4')
Y = Matrix([[ 1/R1+1/R2+1/R4, -1/R4], [-1/R4, 1/R3+1/R4]])

V1, I1 = symbols('V1 I1')
b = Matrix([ V1/R1, I1 ])

Vn1, Vn2 = linsolve((Y, b)).args[0]

```

Algebraic result:

```

>>> Vn1
R2*(I1*R1*R3 + R3*V1 + R4*V1)
-----
R1*R2 + R1*R3 + R1*R4 + R2*R3 + R2*R4
>>> Vn2
R3*R4*(I1*(R1*R2 + R1*R4 + R2*R4) + R2*V1)
-----
-R1*R2*R3 + (R3 + R4)*(R1*R2 + R1*R4 + R2*R4)

```

Numerical result:

```

>>> values = {R1:1, R2:2, R3:3, R4:4, I1:0.5, V1:1}
>>>
>>> f"Vn1 = {Vn1.evalf(3, subs=values)} V"
Vn1 = 0.739 V
>>> f"Vn2 = {Vn2.evalf(3, subs=values)} V"
Vn2 = 1.17 V

```

And the solution to \vec{x} yields

$$\vec{x} = \mathbf{A}^{-1}\vec{b} = \begin{bmatrix} u_2 \\ u_3 \end{bmatrix} = \begin{bmatrix} 0.739 \text{ V} \\ 1.174 \text{ V} \end{bmatrix}$$

From here, knowing the three node voltages u_1 , u_2 , and u_3 is sufficient to quickly derive any of the branch/element currents using the element equations in Step 6. For example, the current i_1 through resistor R_1 is

$$i_1 = \frac{V_{R_1}}{R_1} = \frac{V_s - u_2}{R_1} = 0.261 \text{ A}$$

Deriving the rest of the unknown element currents yields

$$\begin{aligned}
 i_2 &= \frac{V_{R_2}}{R_2} = \frac{u_2 - 0}{R_2} = 0.370 \text{ A} \\
 i_3 &= \frac{V_{R_3}}{R_3} = \frac{u_3 - 0}{R_3} = 0.391 \text{ A} \\
 i_4 &= \frac{V_{R_4}}{R_4} = \frac{u_2 - u_3}{R_4} = -0.108 \text{ A} \\
 i_6 &= i_5 + i_1 = 0.761 \text{ A}
 \end{aligned}$$

Let us consider this particular solution more carefully:

- *What does a negative current in i_4 represent?* For these values of circuit parameters, positive current is flowing in the direction opposite to the (arbitrary) direction for i_4 we defined in

Step 3. This is not an issue in our analysis because we remained consistent in our labeling and when using KCL in Step 6a.

Method 2: Using our linear algebra techniques, we can formulate a matrix-vector representation for *all* circuit node voltages and element/branch currents as

$$\mathbf{A}_2 \vec{x}_2 = \vec{b}_2 \quad \longrightarrow \quad \begin{bmatrix} -1 & 0 & 0 & 0 & 1 & 0 & 0 \\ 1 & -1 & 0 & -1 & 0 & 0 & 0 \\ 0 & 0 & 1 & -1 & 0 & 0 & 0 \\ R_1 & 0 & 0 & 0 & 0 & 1 & 0 \\ 0 & -R_2 & 0 & 0 & 0 & 1 & 0 \\ 0 & 0 & -R_3 & 0 & 0 & 0 & 1 \\ 0 & 0 & 0 & -R_4 & 0 & 1 & -1 \end{bmatrix} \begin{bmatrix} i_1 \\ i_2 \\ i_3 \\ i_4 \\ i_6 \\ u_2 \\ u_3 \end{bmatrix} = \begin{bmatrix} I_s \\ 0 \\ I_s \\ V_s \\ 0 \\ 0 \\ 0 \end{bmatrix}$$

With the given circuit parameters: $R_1 = 1 \, \Omega$, $R_2 = 2 \, \Omega$, $R_3 = 3 \, \Omega$, $R_4 = 4 \, \Omega$, $V_s = 1 \, \text{V}$, $I_s = 0.5 \, \text{A}$; this provides enough information for us to populate matrix \mathbf{A}_2 and vector \vec{b}_2 and solve for the unknowns

$$\vec{x}_2 = \mathbf{A}_2^{-1} \vec{b}_2 = \begin{bmatrix} i_1 \\ i_2 \\ i_3 \\ i_4 \\ i_6 \\ u_2 \\ u_3 \end{bmatrix} = \begin{bmatrix} 0.261, \text{ A} \\ 0.370 \text{ A} \\ 0.391 \text{ A} \\ -0.109 \text{ A} \\ 0.761 \text{ A} \\ 0.739, \text{ V} \\ 1.174, \text{ V} \end{bmatrix}$$

which matches the derived result from the prior system of nine linear equations in *Method 1*.

Again, it turns out that if we know all the node voltages, we can quickly use Ohm's Law (e.g., $i_{1-2} = \frac{u_1 - u_2}{R}$) to derive the currents through each and every resistor and by extension every circuit **branch**. The current through the voltage source however must be obtained with a KCL equation at one of its nodes.

Additional Resources For more on node voltage analysis, read *Schaum's Outline of Electric Circuits*, Seventh Edition, Section 4.4.