

This homework is due March 3, 2015 at 5PM.

We are trying a new style of homework where we include both word problems and mechanical problems (going through straightforward calculation). Problem 5 reflects the mechanical problems, so if you are stuck in any of the preceding problems, try working on problem 5 first. (Note that the mechanical problems do not reflect problems that would be on an exam.)

1. Wire Resistance in the Power Grid

In the United States, a single family household consumes about $2kW$ of electrical power on average. Making some very rough approximations/simplifications (e.g., the power grid actually uses sinusoidal or ‘AC’ voltages to deliver power instead of a constant or ‘DC’ voltage) and as we will see lecture a little bit later on, we can model this situation by considering the power plant as a voltage source with a value of $100V$ (it should really be closer to $110V$, but we want to make the math easy), and each individual house as a current source with a value of $\frac{2kW}{100V} = 20A$. There is one more element we need to include in the model however – the resistance of the physical cables that connect the power plant to our home.

- (a) Assuming that each power plant supplies only one home, draw the circuit model described above, and label the wire resistance as R_{wire} .
- (b) As described in lecture, applying a voltage across a resistor causes it to dissipate power (i.e., generate heat) – the more power we burn on this resistance, the more power the plant needs to deliver to satisfy the requirements at the load, and hence the more we contribute to global warming.

So, let’s assume that we want to allow at most $10V$ across the total wire resistance – for the situation in part (a) (one house and one power plant), what is the largest value of resistance we can tolerate in the wire?

- (c) Now let’s assume that we have two homes right next to each other that are both supplied by the same power plant with the same physical wires - in this case, what is the largest value of wire resistance we can tolerate? Hint: Note that each house should be receiving (close to) $100V$. Therefore, how are the 2 houses connected?
- (d) Sticking with the scenario in part (c) and assuming that our wire has a rectangular cross-section that is $1cm$ on each side, and that the wire is made out of copper, how far away can the power plant be from the two houses?

2. Resistance and Ohm’s Law

The “Internet of Things” (IoT) has gained a lot of popularity over the last couple of years. One of the key ideas underlying the IoT concept is that we will be sensing all kinds of physical properties or quantities in the environment around us (or even in us), and based on inspecting the data, realize some interesting application. Since all of our computational devices that would be inspecting the data deal with electrical quantities, we need to find a way to convert the arbitrary physical quantities into electrical quantities (i.e., voltages). (This is just like in the case of the photodetector where we converted light or photons into electrons, only the exact physical mechanisms and quantities may be quite different.)

It turns out that there are many physical/environmental variables (e.g., temperature, moisture, strain, etc.) that directly modify the electrical resistance of an element, and this is the way many such sensors are realized. In this problem we will explore a very simple example of why the resistance of an element might change due to some physical quantity. We will also build a circuit to convert such a variable resistance into a variable voltage that we could then measure and process further down the road.

- (a) As you all might remember from high-school physics, increasing the temperature of an object causes its physical dimensions (length, width and height) to expand. Assuming our sense resistor can be modeled as a block and the temperature rose enough that *all* dimensions of our sense resistor increased by 10%, how would this change the resistance of the sensor?
- (b) Let's assume that your "lab kit" had the following set of components: an ideal battery that produces a fixed voltage (e.g. a 1.5V AA battery), a current source that produces a constant current (e.g., 0.1A), a set of fixed value resistors (e.g., $1k\Omega$, $10k\Omega$, and $100k\Omega$), and the sensor with variable resistance R_{sense} . Using the minimum number of components, sketch a circuit that would produce a voltage that varies proportionally along with the resistance of the sensor. (Hint: we want to measure the voltage across the resistor R_{sense} .)
- (c) Assuming that the current source produces a current of I_{fixed} , the battery produces a voltage of V_{fixed} , and that your resistors have values $R_{\text{fixed}1}$, $R_{\text{fixed}2}$, etc., write an equation that predicts the voltage V_{sense} produced by your circuit in part (b) as a function of the sensor resistance R_{sense} .
- (d) Now let's say the only things left in your toolbox are the ideal battery and the sensor – can you still build a circuit that produces a voltage that varies proportionally with the sensor's resistance? If so, please sketch the circuit and explain why it works; if not, please explain why it isn't possible.
- (e) Now let's say that we add a single fixed value resistor back into your kit - i.e., you have a battery, sensor, and an additional fixed resistor available. Can you use these components to build a circuit that produces a voltage that varies proportionally with the sensor's resistance? If so, please sketch the circuit and explain why it works; if not, please explain why it isn't possible.
- (f) (Bonus) Write an equation that predicts the voltage V_{sense} produced by your circuit as a function of the battery voltage V_{fixed} , the fixed resistance R_{fixed} , and the sensor's resistance R_{sense} .

3. Ethernet cable

As some of you may already know, when you connect your laptop to the internet through an ethernet cable, the circuits inside of your laptop are able to send data to the router or gateway on the other end at the same time and on the same physical wires as receiving data from the router/gateway. In this problem we'll explore how this might be possible.

- (a) Assuming there are two wires (one for the "signal", and one for "ground") connecting our laptop to the router and each of them has a resistance of R_{cable} , and that the transmitting circuits on the laptop and the router can be modeled as voltage sources with a series resistance of R_s (the resistance of the two sources are equivalent), sketch a model of the complete circuit (i.e. laptop transmitter + wire + router transmitter). You can assume that the voltage being sent by the laptop is V_{laptop} , and that the voltage being sent by the router is V_{router} .
- (b) Using this model, what is the voltage you would actually measure across the two wires at the laptop side of the system? How about on the router side of the system?
- (c) In order for the communication to work, we'd like the laptop (and router) to be able to figure out what value of voltage the router (and laptop) was trying to send. However, the laptop (and router) can only measure the voltage on its side of the cable. In this case, what does the laptop (and router) need to do

in order to recover the router (and laptop) voltage? Write the router's (and laptop's) voltage in terms of the measured voltage. Hint: Each of the router and laptop know what they themselves were trying to send as well as the value of R_s .

- (d) Now let's assume that there is a defect exactly at middle of the cable that leads to a short between the signal and ground wires. Redraw the circuit model for this situation.
- (e) Will the communication between the laptop and the router still work with the defect in part (d)? In either case, show what the voltages on each side of the cable would be and explain how to make the system work or why it can't be made to work.

4. Touchscreen reading

Download `prob4.ipynb` and finish parts (a) through (c). (part d is bonus)

For parts (a) and (b), write out the `filter_matrix`. For both parts, write out the matrix multiplication in your writeup (i.e. not in the ipynb file). For a start, you might want to try writing out the `filter_matrix` for a 3-by-3 image (9 pixels) with a `window_size` of 1. Read the iPython Notebook for explanation on what these are.

5. Mechanical problems

Here are some straightforward calculation problems for exercise.

- (a) Find V_{ab} in the circuit below.

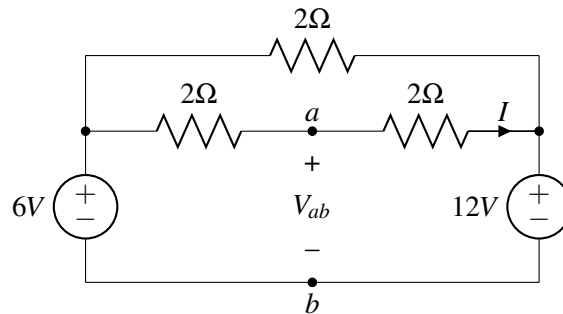

- (b) Determine I_1 , I_2 and I_3 in the circuit below.

