

EECS 16A Designing Information Devices and Systems I

Spring 2019 Discussion 8B

1. Modular Circuits

In this problem, we will explore the design of circuits that perform a set of (arbitrary) mathematical operations. (Note that the so-called analog signal processing – where these kinds of mathematical operations are performed on continuously-valued voltages by analog circuits – is extremely common in real-world applications; without this capability, essentially none of our radios or sensors would actually work.) Specifically, let's assume that we want to implement the block diagram shown below:

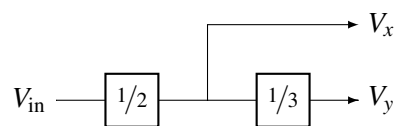

In other words, we want to implement a circuit with two outputs V_x and V_y , where $V_x = \frac{1}{2}V_{in}$ and $V_y = \frac{1}{3}V_x$.

- (a) Design two voltage divider circuits that each independently would implement the two multiplications shown in the block diagram above (i.e., multiply by $\frac{1}{2}$ and multiply by $\frac{1}{3}$). Note that you do not need to include the input voltage sources in your design – you can simply define the input to each block as being at the appropriate potential (e.g., V_{in} or V_x).

Answer:

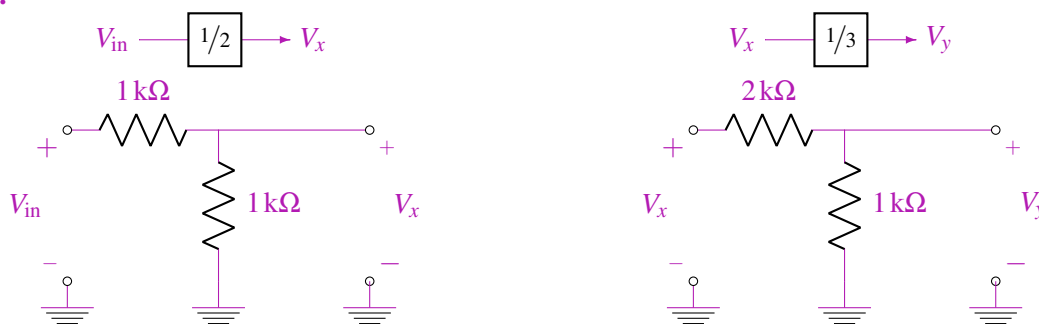

- (b) Assuming that V_{in} is created by an ideal voltage source, implement the original block diagram as a circuit by directly replacing each block with the designs you came up with in part (a).

Answer:

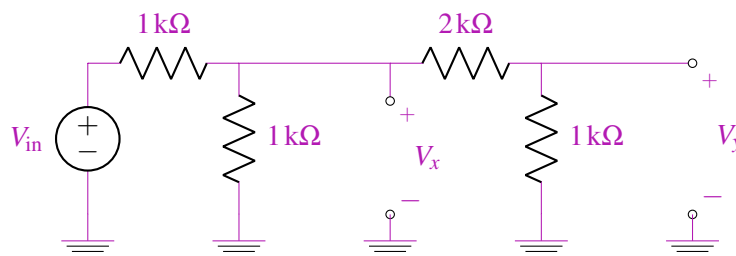

(c) For the circuit from part (b), do you get the desired relationship between V_y and V_x ? How about between V_x and V_{in} ? Be sure to explain why or why not each block retains its desired functionality.

Answer:

The relationship between V_y and V_x will be correct. We can apply the voltage divider equation to the two rightmost resistors to see this:

$$V_y = \frac{1\text{ k}\Omega}{1\text{ k}\Omega + 2\text{ k}\Omega} V_x = \frac{1}{3} V_x$$

The relationship between V_x and V_{in} will not be correct. To see this, we can redraw the circuit applying resistance series and parallel rules.

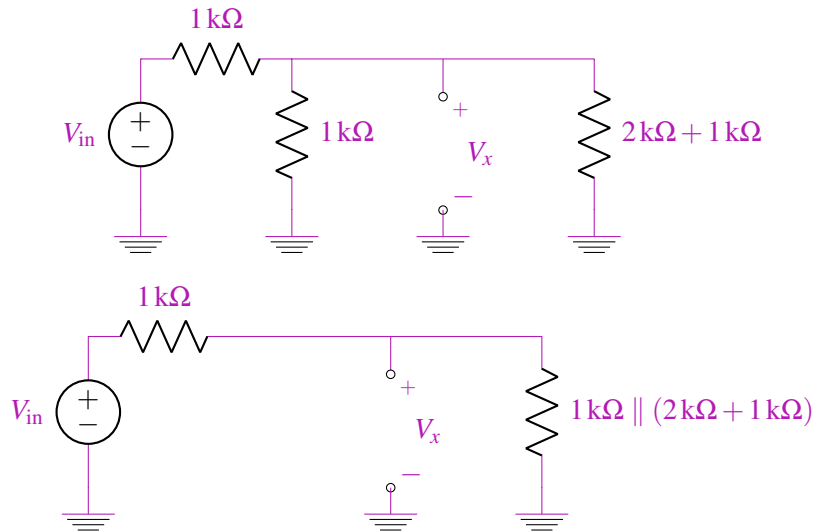

Now we can apply the voltage divider equation to see that:

$$V_x = \frac{1\text{ k}\Omega \parallel (2\text{ k}\Omega + 1\text{ k}\Omega)}{1\text{ k}\Omega + 1\text{ k}\Omega \parallel (2\text{ k}\Omega + 1\text{ k}\Omega)} V_{in} = \frac{3}{7} V_{in}$$

which was not the desired relationship between V_x and V_{in} .

(d) Now let's assume that we have discovered compose-able circuits that implement mathematical operations. In particular, we have these blocks that implement:

- i. $V_o = 5V_i$
- ii. $V_o = -2V_i$
- iii. $V_o = V_{i_1} + V_{i_2}$

Using just these blocks, draw the block diagram that implements:

- i. $V_o = -12V_{in_1}$
- ii. [PRACTICE] $V_o = -10V_{in_1} - 2V_{in_2}$
- iii. [PRACTICE] $V_o = -V_{in_1} + V_{in_2}$

Answer:

i.

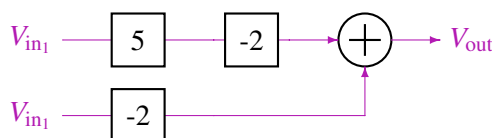

ii.

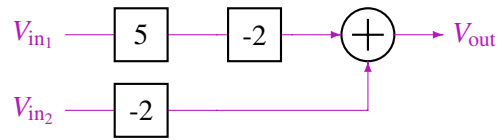

iii.

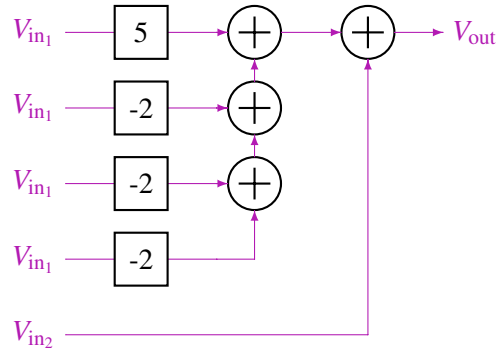

2. Op-Amps As Comparators

For each of the circuits shown below, plot V_{out} for V_{in} ranging from -10 V to 10 V for part (a) and from 0 V to 10 V for part (b). Let $A = 100$ for your plots. Note that in real op amps, A is typically much higher (i.e. $10^4 - 10^7$).

(a)

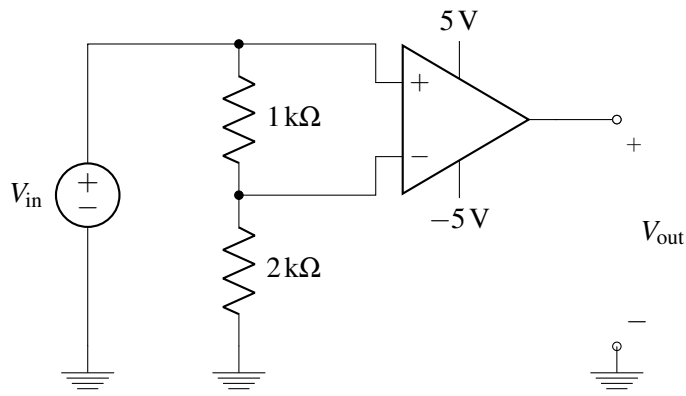

Answer:

$$\begin{aligned}
 V_+ &= V_{in} \\
 V_- &= \frac{2\text{ k}\Omega}{1\text{ k}\Omega + 2\text{ k}\Omega} V_{in} = \frac{2}{3} V_{in} \\
 V_{out} &= A(V_+ - V_-) + \frac{V_S^+ - V_S^-}{2} + V_S^- \\
 &= AV_{in} \left(1 - \frac{2}{3} \right) + \frac{5 - (-5)}{2} + (-5) = \frac{1}{3} AV_{in}
 \end{aligned}$$

The op-amp satisfies the linear relation above for $V_S^- \leq V_{out} \leq V_S^+$.

$$\begin{aligned}
 V_S^- &\leq V_{out} \leq V_S^+ \\
 V_S^- &\leq \frac{1}{3} AV_{in} \leq V_S^+ \\
 3 \frac{V_S^-}{A} &\leq V_{in} \leq 3 \frac{V_S^+}{A} \\
 3 \frac{-5\text{ V}}{100} &\leq V_{in} \leq 3 \frac{5\text{ V}}{100} \\
 -0.15\text{ V} &\leq V_{in} \leq 0.15\text{ V}
 \end{aligned}$$

The op-amp saturates outside of this range.

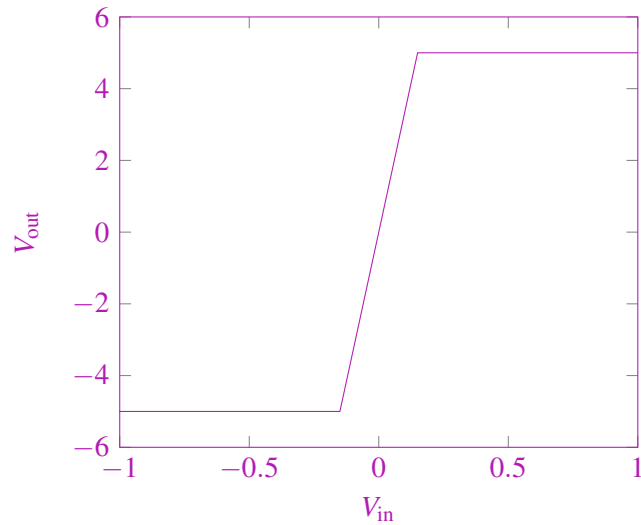

(b) [PRACTICE]

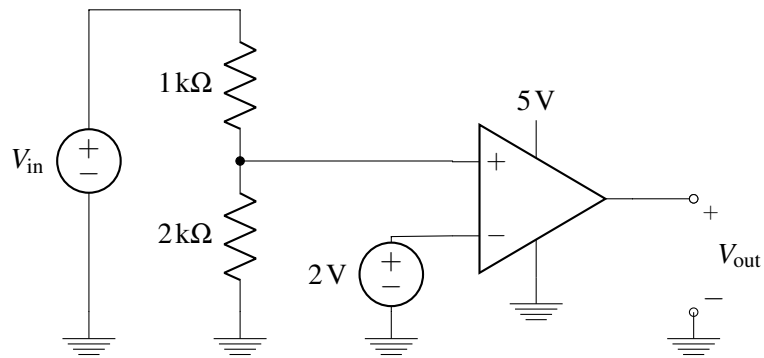
**Answer:**

$$V_+ = \frac{2\text{k}\Omega}{1\text{k}\Omega + 2\text{k}\Omega} V_{\text{in}} = \frac{2}{3} V_{\text{in}}$$

$$V_- = 2\text{V}$$

$$V_{\text{out}} = A(V_+ - V_-) + \frac{V_S^+ - V_S^-}{2} + V_S^-$$

$$= A\left(\frac{2}{3}V_{\text{in}} - 2\right) + \frac{5 - 0}{2} + 0$$

$$= A\left(\frac{2}{3}V_{\text{in}} - 2\right) + 2.5$$

The op-amp satisfies the linear relation above for $V_S^- \leq V_{\text{out}} \leq V_S^+$.

$$\begin{aligned}
 V_S^- &\leq V_{\text{out}} \leq V_S^+ \\
 V_S^- &\leq A \left(\frac{2}{3} V_{\text{in}} - 2 \right) + 2.5 \leq V_S^+ \\
 \frac{3}{2} \left(\frac{V_S^- - 2.5}{A} + 2 \right) &\leq V_{\text{in}} \leq \frac{3}{2} \left(\frac{V_S^+ - 2.5}{A} + 2 \right) \\
 \frac{3}{2} \left(\frac{-2.5 \text{ V}}{100} + 2 \right) &\leq V_{\text{in}} \leq \frac{3}{2} \left(\frac{5 \text{ V} - 2.5 \text{ V}}{100} + 2 \right) \\
 2.9625 \text{ V} &\leq V_{\text{in}} \leq 3.0375 \text{ V}
 \end{aligned}$$

The op-amp saturates outside of this range.

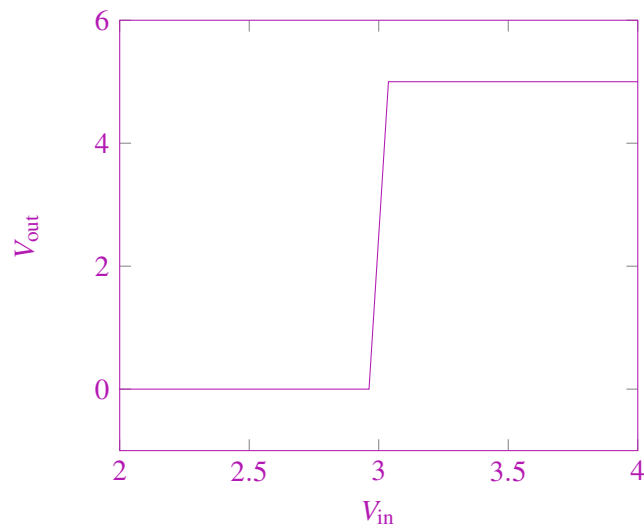

3. Current Sources And Capacitors

For the circuits given below, give an expression for $v_{\text{out}}(t)$ in terms of I_s , C_1 , C_2 , C_3 , and t . Assume that all capacitors are initially uncharged, i.e. the initial voltage across each capacitor is 0V.

(a)

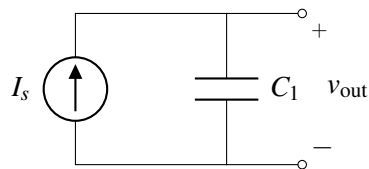

Answer:

$$\begin{aligned}
 I_s &= C_1 \frac{dv_{\text{out}}(t)}{dt} \\
 v_{\text{out}}(t) &= \int \frac{I_s}{C_1} dt = \frac{I_s t}{C_1} + v_{\text{out}}(0)
 \end{aligned}$$

Since the capacitor is initially uncharged, $v_{\text{out}}(0) = 0$, so $v_{\text{out}}(t) = \frac{I_s t}{C_1}$.

(b)

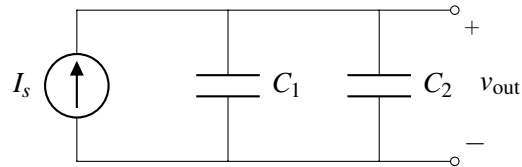
**Answer:**

We can combine the two capacitors into an equivalent capacitor with capacitance $C_1 + C_2$. Again, $v_{out}(0) = 0$ because all capacitors are initially uncharged.

$$I_s = (C_1 + C_2) \frac{dv_{out}(t)}{dt}$$

$$v_{out}(t) = \frac{I_s t}{C_1 + C_2} + v_{out}(0) = \frac{I_s t}{C_1 + C_2}$$

4. Maglev Train Height Control System [PRACTICE]

One of the fastest forms of land transportation are trains that actually travel slightly elevated from ground using magnetic levitation (or “maglev” for short). Ensuring that the train stays at a relatively constant height above its “tracks” (the tracks in this case are what provide the force to levitate the train and propel it forward) is critical to both the safety and fuel efficiency of the train. In this problem, we’ll explore how the maglev trains use capacitors to keep them elevated. (Note that real maglev trains may use completely different and much more sophisticated techniques to perform this function, so if you e.g. get a contract to build such a train, you’ll probably want to do more research on the subject.)

- (a) As shown below, let’s imagine that all along the bottom of the train, we put two parallel strips of metal (T_1 , T_2), and that on the ground below the train (perhaps as part of the track), we have one solid piece of metal (M).

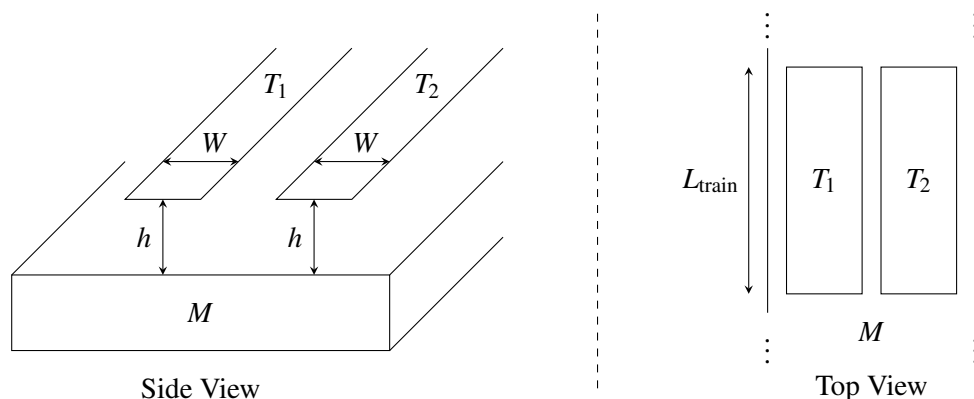

Assuming that the entire train is at a uniform height above the track and ignoring any fringing fields (i.e., all capacitors are purely parallel plate), as a function of L_{train} (the length of the train), W (the width of T_1/T_2), and h (the height of the train off of the track), what is the capacitance between T_1 and M ? How about the capacitance between T_2 and M ?

Answer:

The distance between the plates (T_1 & M or T_2 & M) is h . The area of plate for the parallel plate capacitor is $A = WL_{\text{train}}$. Using the formula for capacitance of a parallel plate capacitor, we get:

$$C = \frac{\epsilon A}{d}$$

$$C_1 = \frac{\epsilon WL_{\text{train}}}{h} \text{ (Capacitance between } T_1 \text{ and M)}$$

$$C_2 = \frac{\epsilon WL_{\text{train}}}{h} \text{ (Capacitance between } T_2 \text{ and M)}$$

- (b) Any circuit on the train can only make direct contact at T_1 and T_2 . To detect the height of the train, it would only be able to measure the effective capacitance between T_1 and T_2 . Draw a circuit model showing how the capacitors between T_1 and M and between T_2 and M are connected to each other.

Answer:

The capacitors C_1 and C_2 are in series. To realize this, let's consider the train circuit that is in contact with T_1 and T_2 . If there is current entering plate T_1 , the same current has to exit plate T_2 . Thus, the circuit can be modeled as follows:

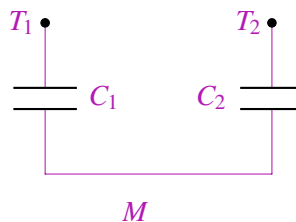

- (c) Using the same parameters as in part (a), provide an expression for the capacitance between T_1 and T_2 .

Answer:

Since the two capacitors are in series, the effective capacitance between T_1 and T_2 is given by:

$$\frac{1}{C_{\text{eq}}} = \frac{1}{C_1} + \frac{1}{C_2}$$

Thus, we get

$$\frac{1}{C_{\text{eq}}} = \frac{h}{\epsilon WL_{\text{train}}} + \frac{h}{\epsilon WL_{\text{train}}}$$

$$C_{\text{eq}} = \frac{\epsilon WL_{\text{train}}}{2h}$$

- (d) So far we've assumed that the height of the train off of the track is uniform along its entire length, but in practice, this may not be the case. Suggest and sketch a modification to the basic sensor design (i.e., the two strips of metal T_1/T_2 along the entire bottom of the train) that would allow you to measure the height at the train at 4 different locations.

Answer:

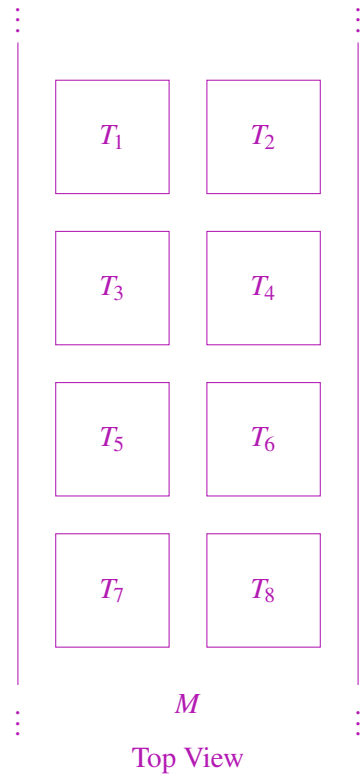

One important thing to note about this circuit is that it works only if extra care is taken during the capacitance measurement circuit. The equivalent model for this is:

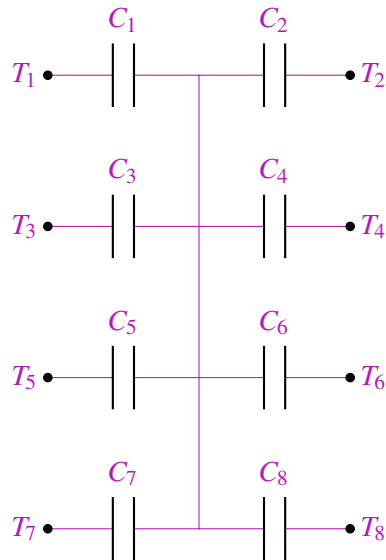

Therefore, the circuit needs separate switches on each T , so that you can measure the capacitance between only two terminals (like T_1 & T_2) and so that the effect of other capacitors is nullified.