EECS 16A Designing Information Devices and Systems I

Spring 2019 Homework 8

This homework is due March 22, 2019, at 23:59.

Self-grades are due April 2, 2019, at 23:59.

Submission Format

Your homework submission should consist of **one** file.

- `hw8.pdf`: A single PDF file that contains all of your answers (any handwritten answers should be scanned).

Submit the file to the appropriate assignment on Gradescope.

1. Thévenin and Norton Equivalent Circuits

- (a) Find the Thévenin and Norton equivalent circuits seen from outside of the box.

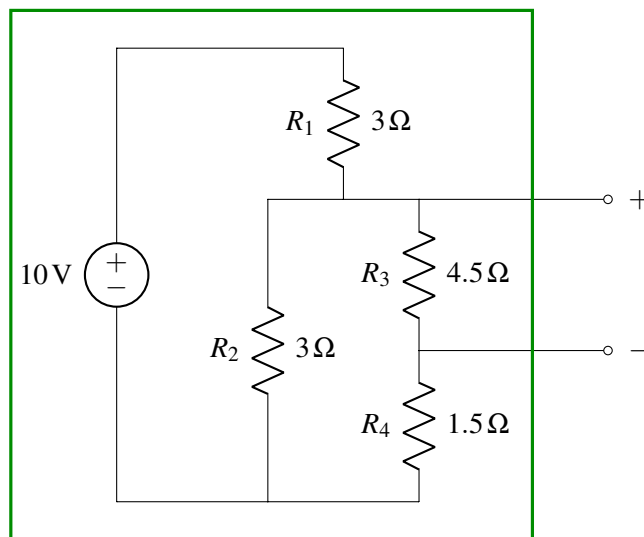

- (b) Find the Thévenin and Norton equivalent circuits seen from outside of the box.

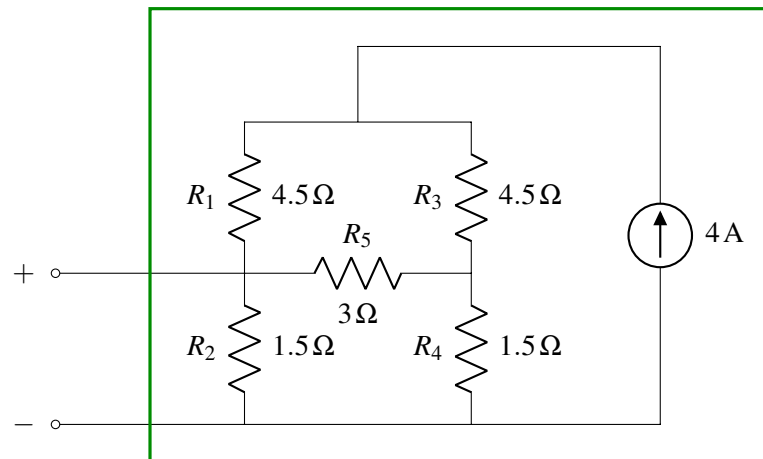

2. Measuring Voltage and Current

In order to measure quantities such as voltage and current, engineers have designed circuits known as Analog to Digital Converters, or ADCs. While ADCs are very complicated circuits in reality, a simple model of an ADC is a resistor with a very high resistance, R_{ADC} . **The ADC measures the voltage across the resistance R_{ADC} .** The measured voltage is then relayed to a microprocessor (such as the MSP430s used in Lab). We can use this ADC to create both a voltmeter and an ammeter (A voltmeter is an instrument that measures voltage, while an ammeter measures current). This model of an ADC is shown in Figure 1. Let us explore what happens when we connect this ADC to various circuits to measure voltages and currents. Throughout this problem assume $R_{ADC} = 1M\Omega$. Recall that the SI prefix M or Mega is 10^6 .

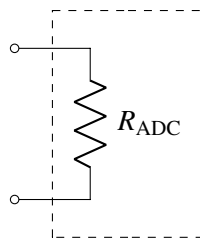

Figure 1: Our Model of an ADC, $R_{ADC} = 1M\Omega$

- (a) Suppose we wanted to measure the voltage across R_2 (v_{out}) produced by the voltage divider circuit shown in Figure 2 on the left. The circuit on the right in Figure 2 shows how we would connect the ADC across R_2 to function as a voltmeter. Assume $R_1 = 100\Omega$ and $R_2 = 100\Omega$. First calculate the value of v_{out} . Then calculate the voltage ADC would measure, i.e. v_{meas} .

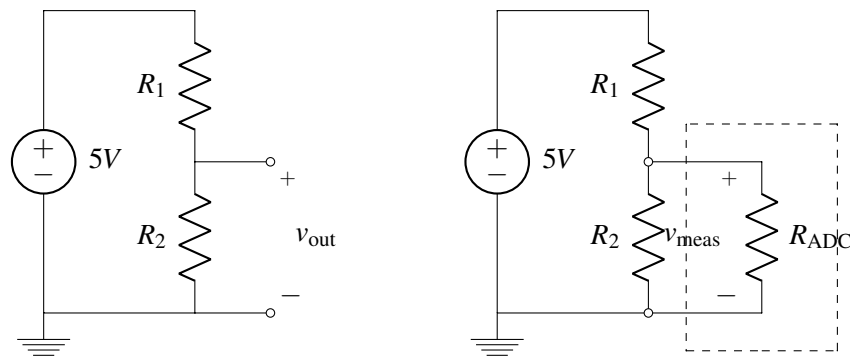

Figure 2: Left: Circuit without the ADC connected, Right: ADC measuring voltage across R_2

- (b) Repeat part a), but now $R_1 = 10M\Omega$ and $R_2 = 10M\Omega$. Is this ADC still a good tool to measure the output voltage?
- (c) Now suppose we are working with the same circuit as in Part (a), but we know that $R_2 = R_1$. What is the maximum value of R_1 that ensures that the difference between voltage measurement of the ADC (v_{meas}) and the actual value (v_{out}) remains within $\pm 10\%$ of v_{out} ?
- (d) As mentioned before, we can use an ADC to measure the current through an element as well, where the ADC functions as an ammeter. Your colleague suggests you use the circuit shown in Figure 3, where $R_x = 1\Omega$, then the measured current through R_x is $I_{meas} = \frac{V_{ADC}}{R_x}$ where V_{ADC} is the voltage across the ADC.

In Figure 4, the ADC is connected to measure the current through resistor $R_1 = 1k\Omega$. For the circuit on the left, find the current through R_1 without the ADC connected (i.e. I_1). Then for the circuit on the right, find the current measured by the ADC when it is connected as an ammeter (i.e. I_{meas}).

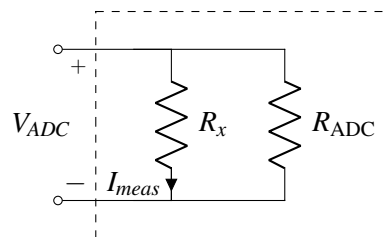

Figure 3: The ADC connected to measure current, $R_{ADC} = 1M\Omega$

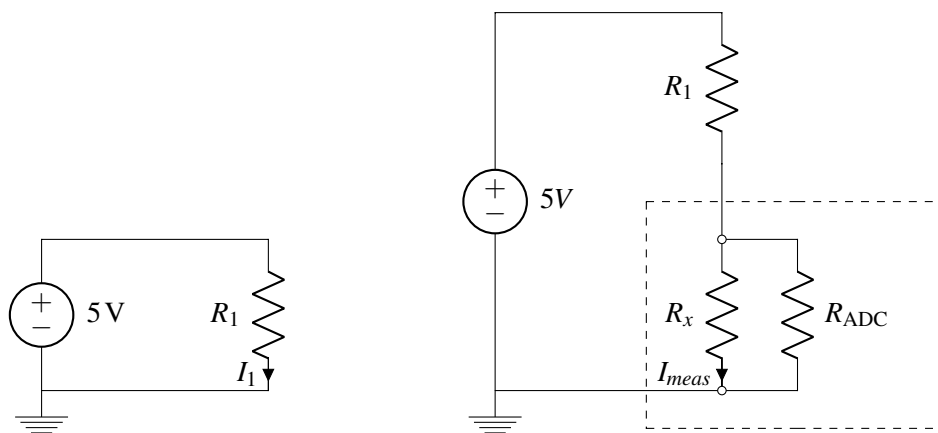

Figure 4: Circuits for Part (d) Left: Original circuit; Right: Circuit with the ADC measuring current

- (e) What is the minimum value of R_1 that ensures the difference between current measurement (I_{meas}) and the actual value (I_1) stays within $\pm 10\%$ of I_1 ?

3. Digital to Analog Converter (DAC)

For some outputs, such as audio applications, we need to produce an analog output, or a continuous voltage from 0 to V_s . These analog voltages must be produced from digital voltages, that is sources, that can only be V_s or 0. A circuit that does this is known as a Digital to Analog Converter. It takes a binary representation of a number and turns it into an analog voltage.

The output of a DAC can be represented with the equation shown below:

$$V_{out} = V_s \sum_{n=0}^N \frac{1}{2^n} \cdot b_n$$

where each binary digit b_n is multiplied by $\frac{1}{2^n}$.

- (a) We know how to take an input voltage and divide it by 2:

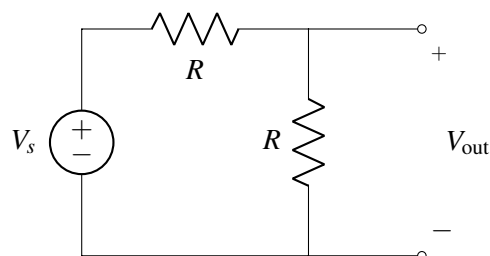

To divide by larger powers of two, we might hope to just “cascade” the above voltage divider. For example, consider:

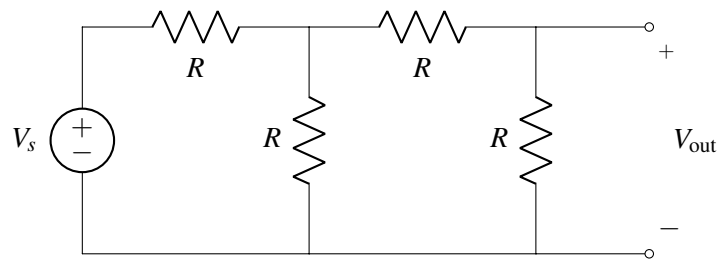

Calculate V_{out} in the above circuit. Is $V_{out} = \frac{1}{4}V_s$?

(b) The R - $2R$ ladder, shown below, has a very nice property. For each of the circuits shown below, find the equivalent resistance looking in from points a and b . Do you see a pattern?

i.

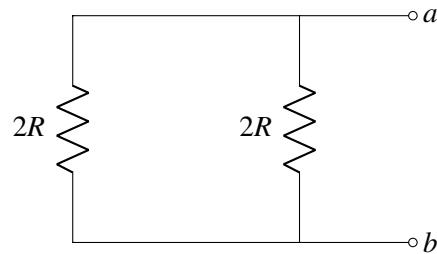

ii.

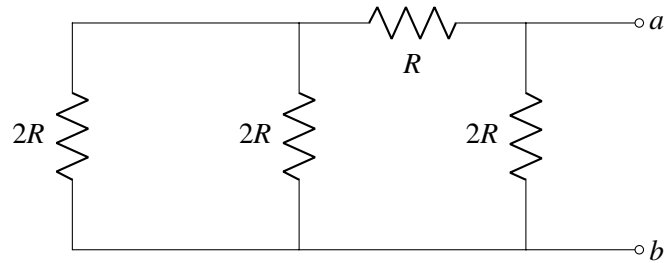

iii.

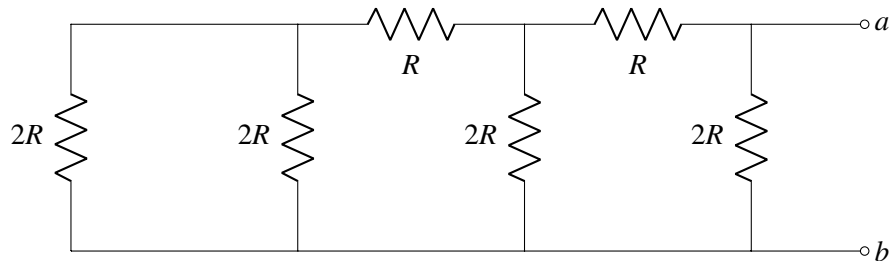

(c) The following circuit is an R - $2R$ DAC. To understand its functionality, use superposition to find V_{out} in terms of each V_k in the circuit.

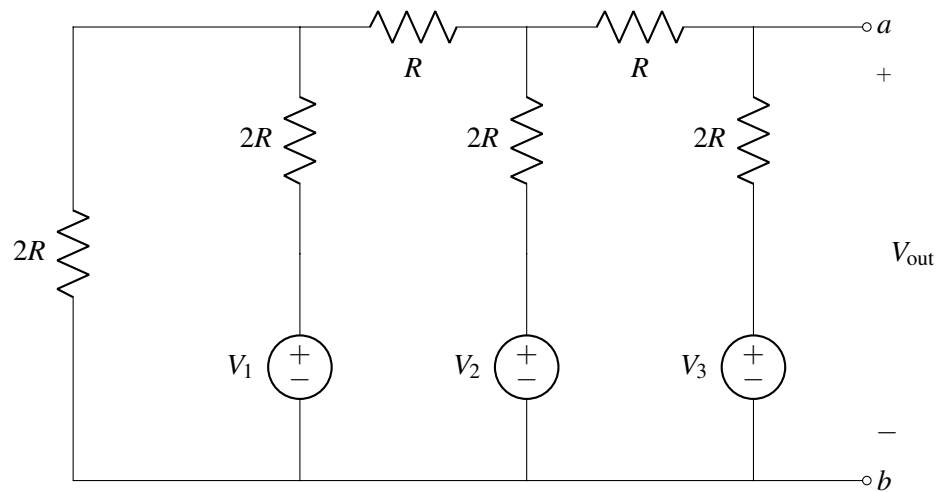

- (d) We've now designed a 3-bit R - $2R$ DAC. What is the output voltage V_{out} if $V_2 = 1\text{ V}$ and $V_1 = V_3 = 0\text{ V}$?
- (e) Draw the Thévenin equivalent of the above circuit, looking in from the terminals a and b with $V_2 = 1\text{ V}$ and $V_1 = V_3 = 0\text{ V}$.
- (f) Suppose that we now attach a speaker to the DAC with a resistance of $\frac{R}{7}$. Why is the voltage across the speaker lower than what we computed in part (d)? What is the actual output voltage?

4. Wheatstone Bridge

Thévenin equivalence is a powerful technique we can use to solve the Wheatstone bridge circuit shown below. This circuit is used in many sensor applications where a sensing element is the "bridge" resistor, R_3 . It is often useful to find the current through the bridge resistor or the voltage across the bridge resistor. Intuitively, knowing I_{R_3} or V_{R_3} allows us to solve the rest of the circuit. In this problem, we want to find the current I_{R_3} flowing through the bridge resistor R_3 .

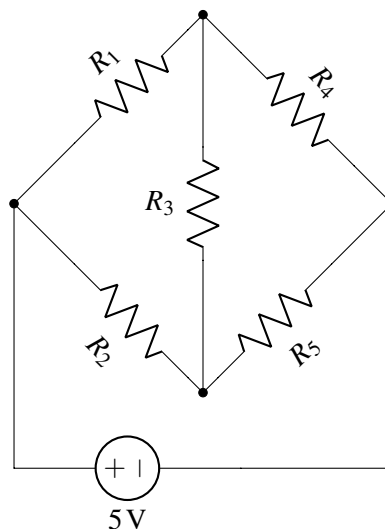

- (a) First, let's remove the bridge resistor R_3 . Calculate the Thévenin equivalent voltage V_{th} between the two terminals a and b , for the circuit shown below, where the bridge resistor has been removed.

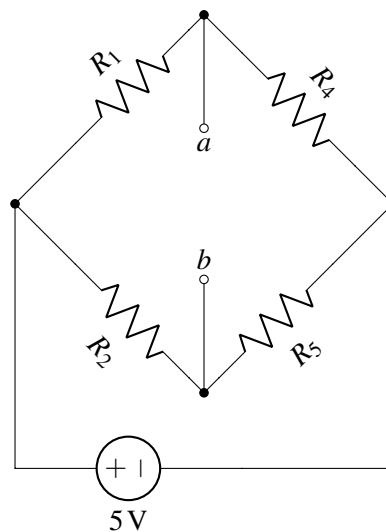

- (b) Is the Thévenin voltage V_{Th} you found in part (a) equal to the actual voltage V_{R_3} across the bridge resistor? Why or why not?
- (c) Find the Thévenin resistance R_{Th} between the two terminals a and b for the above circuit. Draw the Thévenin equivalent between the terminals a and b for the circuit above.
- (d) With the Thévenin equivalent circuit, calculate the current I_{R_3} through the bridge resistor and the voltage V_{R_3} across the bridge resistor.

5. Homework Process and Study Group

Who else did you work with on this homework? List names and student ID's. (In case of homework party, you can also just describe the group.) How did you work on this homework?