

**This homework is due on Sunday, July 30, 2017, at 23:59.**

**Self-grades are due on Monday, July 31, 2017, at 23:59.**

### Submission Format

Your homework submission should consist of **one** file.

- `hw6.pdf`: A single PDF file that contains all of your answers (any handwritten answers should be scanned).

Submit the file to the appropriate assignment on Gradescope.

## 1. Academic Honesty

Carefully read UC Berkeley's policy on academic misconduct (<http://sa.berkeley.edu/conduct/integrity/definition>) and the EECS department policy on academic dishonesty (<https://eecs.berkeley.edu/resources/students/academic-dishonesty>).

- What constitutes own work and thus permissible work?
- What forms of work is disallowed because it is not your own work?

## 2. Island Karaoke Machine

After a plane crash, you're stuck on a desert island and everyone is bored out of their minds. Fortunately, you have your EE16A lab kit with op amps, wires, resistors, and your handy breadboard. You decide to build a karaoke machine. You recover one speaker from the crash remains and use your iPhone as your source. You know that many songs put instruments on either the "left" or the "right" channel, but the vocals are usually present on both channels with equal strength.

The Thevenin equivalent model of the iPhone audio jack and speakers is shown below. For simplicity, we assume that the audio signals  $V_{\text{left}}$  and  $V_{\text{right}}$  are both DC and that the equivalent source resistance of the left/right audio channels of  $R_{\text{left}} = R_{\text{right}} = 3\ \Omega$ . The speaker has an equivalent resistance of  $4\ \Omega$ .

For this problem, we'll assume that

$$\begin{aligned}V_{\text{left}} &= V_{\text{vocals}} \\V_{\text{right}} &= V_{\text{vocals}} + V_{\text{instrument}},\end{aligned}$$

where  $V_{\text{vocals}} = 120.524\text{mV}$  and  $V_{\text{instrument}} = 50\text{mV}$ .

That is, the vocals are present on the left and right channel, but the instrument is present only on the right channel.

What is the goal of a karaoke machine? The ultimate goal is to *remove* the vocals from the audio output. We're going to do this by first building a circuit that takes the left and right outputs of the smartphone audio output and then takes its difference. Let's see what happens.

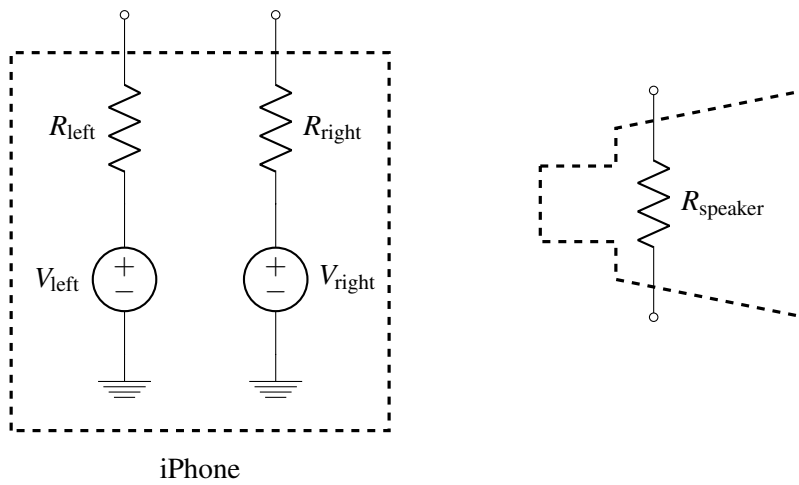

- (a) One of your island survivors suggests the following circuit to do this. Calculate the voltage across the speaker. What do you notice? Does the voltage across the speaker depend on  $V_{\text{vocals}}$ ? What do you think the islanders will hear – vocals, instruments, or both?

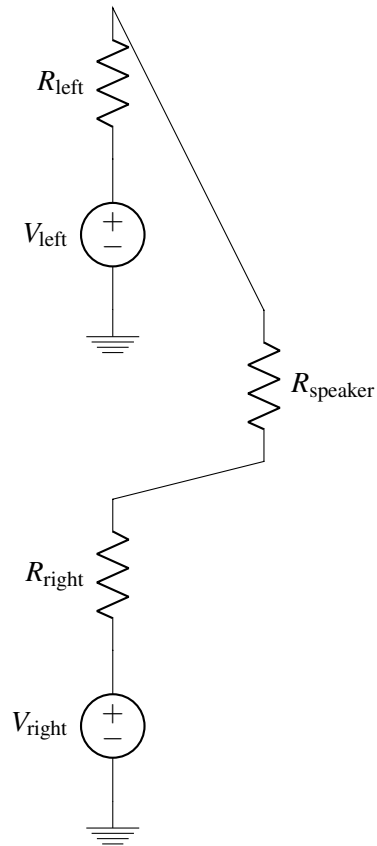

- (b) How much power is delivered to the speaker?
- (c) Clearly, we need to boost the sound level to get the party going. We can do this by *amplifying* both  $V_{\text{left}}$  and  $V_{\text{right}}$ . Keep in mind that we could use inverting or non-inverting amplifiers.

Let's assume, just for this part, that all the amplifiers we have produce a gain of 100 (if they are non-inverting) and  $-100$  (if they are inverting). How would you take the difference of the two amplified outputs across the speaker?

- (d) Now, design a circuit that takes in  $V_{\text{left}}$  and  $V_{\text{right}}$  and outputs an amplified version of  $V_{\text{instrument}}$  across the speaker load. You should be able to deliver 1 W into the speaker load. You can use up to three op amps, and each of them can be inverting or non-inverting.
- (e) The trouble with the previous part is the number of op amps required. Let's say you only have one op amp with you. What would you do? One night in your dreams, you have an inspiration. Why not combine the inverting and non-inverting amplifier into one, as shown below!

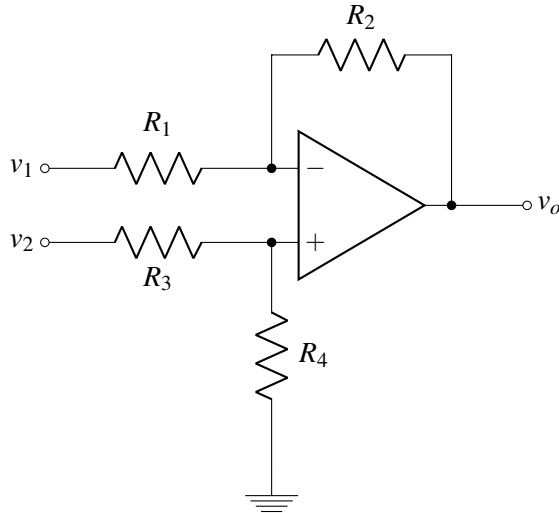

If we set  $v_2 = 0\text{V}$ , what is the gain from  $v_1$  to the output  $v_o$ ? (This is the inverting path.)

- (f) If we set  $v_1 = 0\text{V}$ , what is the gain from  $v_2$  to the output  $v_o$ ? (This is the non-inverting path.)
- (g) Now, determine  $v_o$  in terms of  $v_1$  and  $v_2$ . (*Hint:* Use superposition.) Set  $R_1$ ,  $R_2$ ,  $R_3$  and  $R_4$ , such that, as before, 1 W is delivered to the speaker load and we don't hear the vocals.

### 3. Jumpbot

In this problem, you will be designing circuits allowing a robot named Jumpbot to execute a set of commands that will be described below. Specifically, the output voltages produced by your circuits are interpreted by Jumpbot as setting its vertical position in meters in free space (both positive and negative values will be used). You will be generating a oscillating triangular waveform with a controllable time period.

- (a) One of the circuit blocks you will use to generate the triangular waveform is the integrator. An integrator integrates the input signal. For the circuit given below express  $v_1$  in terms of  $R_1$ ,  $C_1$ , and  $v_0$ .

*Hint:* You will have to apply KCL, and the current flowing through a capacitor is given by  $I = C \frac{dV}{dt}$ .

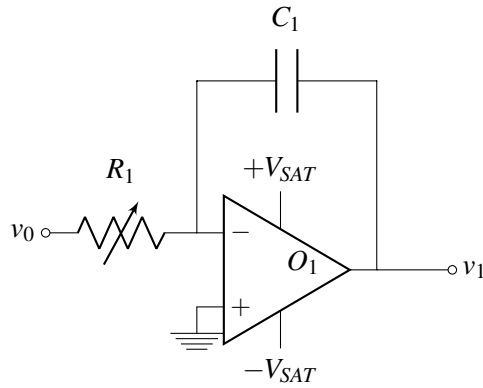

(b) The waveform for  $v_1$  with input  $v_0$  given is below. Here,  $T$  is the time period. Derive expressions for  $T_1$  and  $T_2$  as a function of  $R_1$ ,  $C_1$ ,  $V_{TH}$ , and  $V_{SAT}$ . Here,  $+V_{TH}$  and  $-V_{TH}$  are set using a comparator, which we will discuss in the next part.

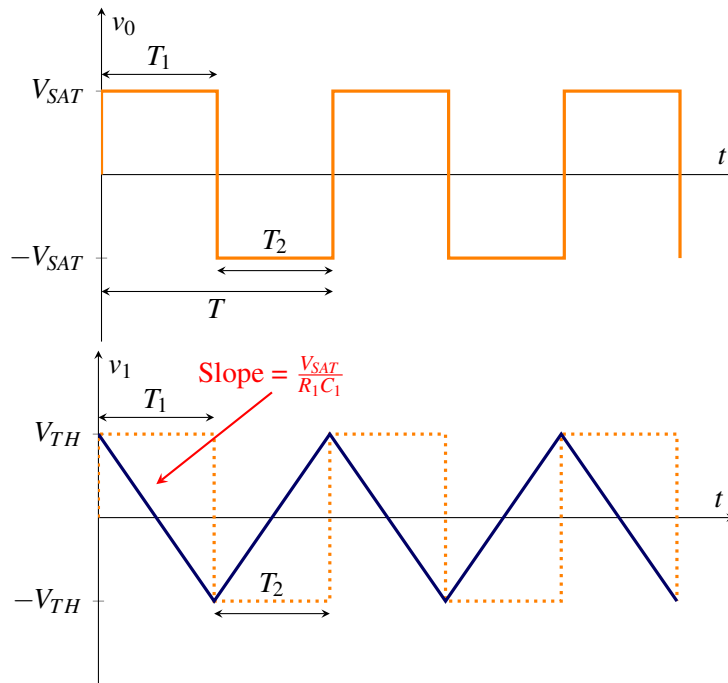

(c) Now that we know how to generate a triangular waveform, we can use that for the jumpbot. However, we need to set up the initial signal ( $v_0$ ) that helped us to create the triangular waveform ( $v_1$ ). For the circuit below, draw the waveform ( $v_2$ ) if we use  $v_1$  from part (b) as the input. Now, draw the waveform ( $v_2$ ) if we use  $-v_1$ . Which  $v_2$  ( $v_1$  as input or  $-v_1$  as input) matches  $v_0$  from part (a)?

$$+V_{TH} = \frac{R_4}{R_4 + R_5} V_{SAT}$$

$$-V_{TH} = \frac{R_4}{R_4 + R_5} (-V_{SAT})$$

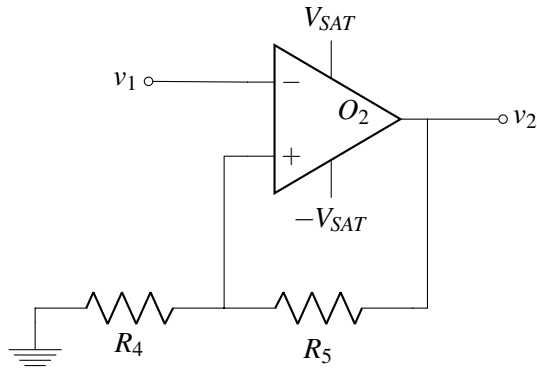

- (d) Implement the circuits from part (a) and (c) for controlling the jumpbot using  $v_1$ . You may need to insert another circuit block in the middle to get the right polarity at the input terminal of the circuit in (c). Draw out your full circuit.
- (e) In your circuit, if  $\pm V_{SAT} = \pm 10\text{ V}$ ,  $C_1 = 0.01\text{ mF}$ , and  $R_4 = 10\text{ k}\Omega$ , find the values for  $R_1$  and  $R_5$ , so that the jumpbot jumps with  $10\text{ V}$  peak-to-peak amplitude ( $\pm V_{TH} = \pm 5\text{ V}$ ) with  $1\text{ kHz}$  frequency (period =  $1 / \text{frequency}$ ).

#### 4. Rain Sensor v2.0

In homework 5, we analyzed a rain sensor built by a lettuce farmer in Salinas Valley. They used a rectangular tank outside and attached two metal plates to two opposite sides in an effort to make a capacitor whose capacitance varies with the amount of water inside. The width and length of the tank are both  $w$  (i.e. the base is square), and the height of the tank is  $h_{\text{tot}}$ .

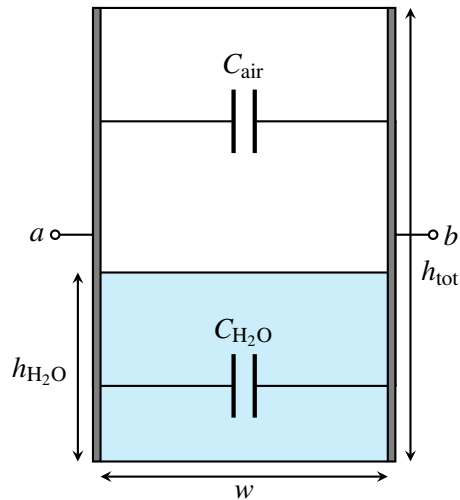

As your EE16A circuits toolkit is now complete with capacitors, op-amps, and switches, we will revisit this problem to improve the readout electronics. The goal is to create a circuit block that will output voltage as a linear function of the water height,  $h_{\text{H}_2\text{O}}$ .

- (a) What is the capacitance between terminals  $a$  and  $b$  when the tank is empty,  $C_{\text{empty}}$ ? Again, the height of the water in the tank is  $h_{\text{H}_2\text{O}}$ . Modeling the tank as a pair of capacitors in parallel, find the total capacitance  $C_{\text{tank}}$  between the two plates. Can you write  $C_{\text{tank}}$  as a function of  $C_{\text{empty}}$ ?  
*Note:* The permittivity of air is  $\epsilon$ , and the permittivity of rainwater is  $81\epsilon$ .

(b) One of the limitations of the previous readout circuit implementation was that it relied on capacitive charge sharing. Here, we will analyze a circuit that transfers all charges for efficient readout. For the circuit below, draw the output waveform of  $v_{out}$  as a function of  $v_{in}$ ,  $C_f$ , and  $C_{in}$ .

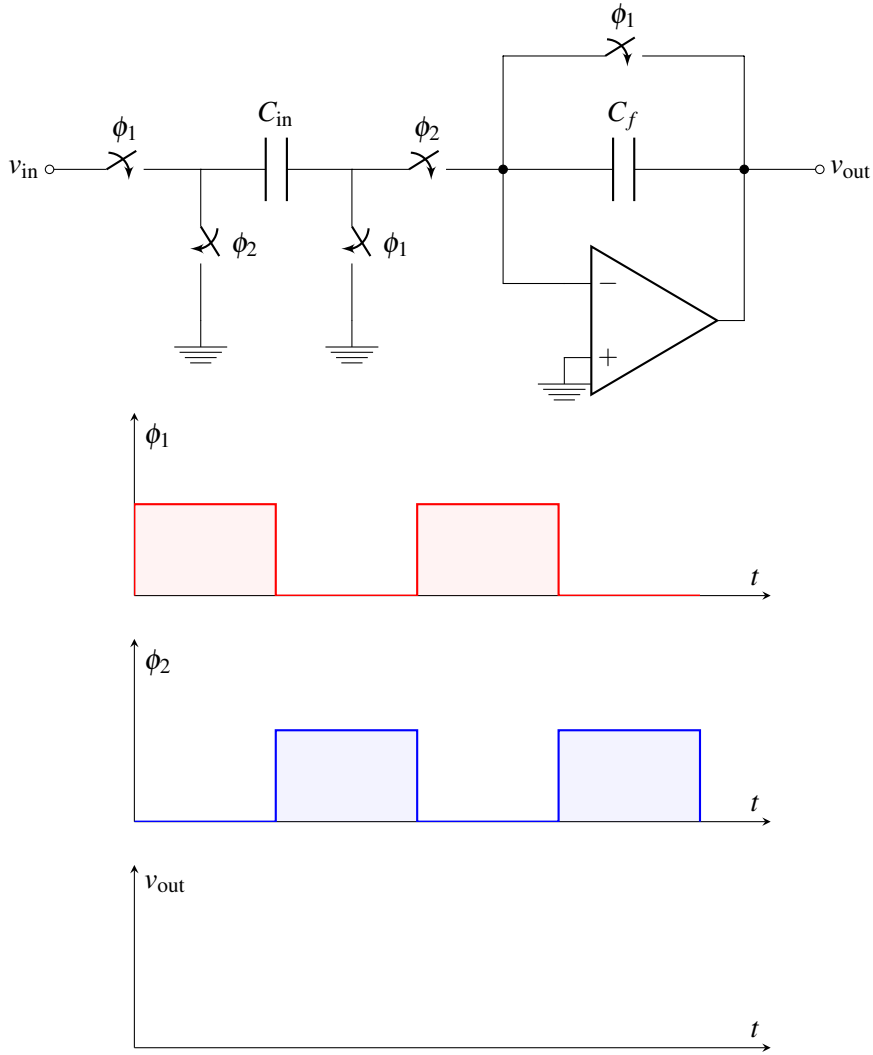

(c) The previous configuration is the non-inverting configuration. Now, we will look into the inverting configuration. For the circuit below, draw the output waveform of  $v_{out}$  as a function of  $v_{in}$ ,  $C_f$ , and  $C_{in}$ .

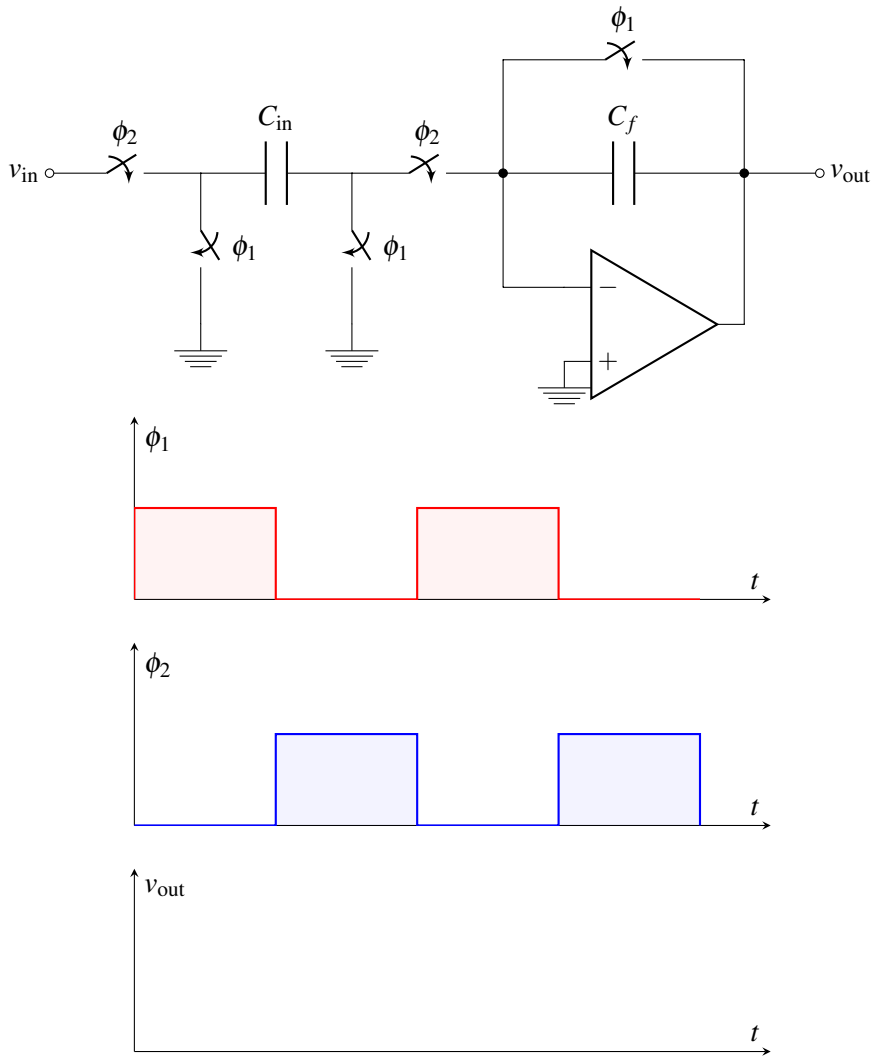

(d) With the help of the basic circuit blocks shown in parts (b) and (c), we will now implement a circuit that will output voltage as a linear function of the water height,  $h_{H_2O}$ . In addition to the rain-sensing capacitor, we will use two fixed value capacitors  $C_{fixed}$  and  $C_{empty}$ . Use the values obtained in part (a) for  $C_{tank}$  and  $C_{empty}$ . For the circuit below, draw the output waveform of  $v_{out}$  as a function of  $v_{in}$ ,  $C_{fixed}$ ,  $\epsilon$ , and  $h_{H_2O}$ .

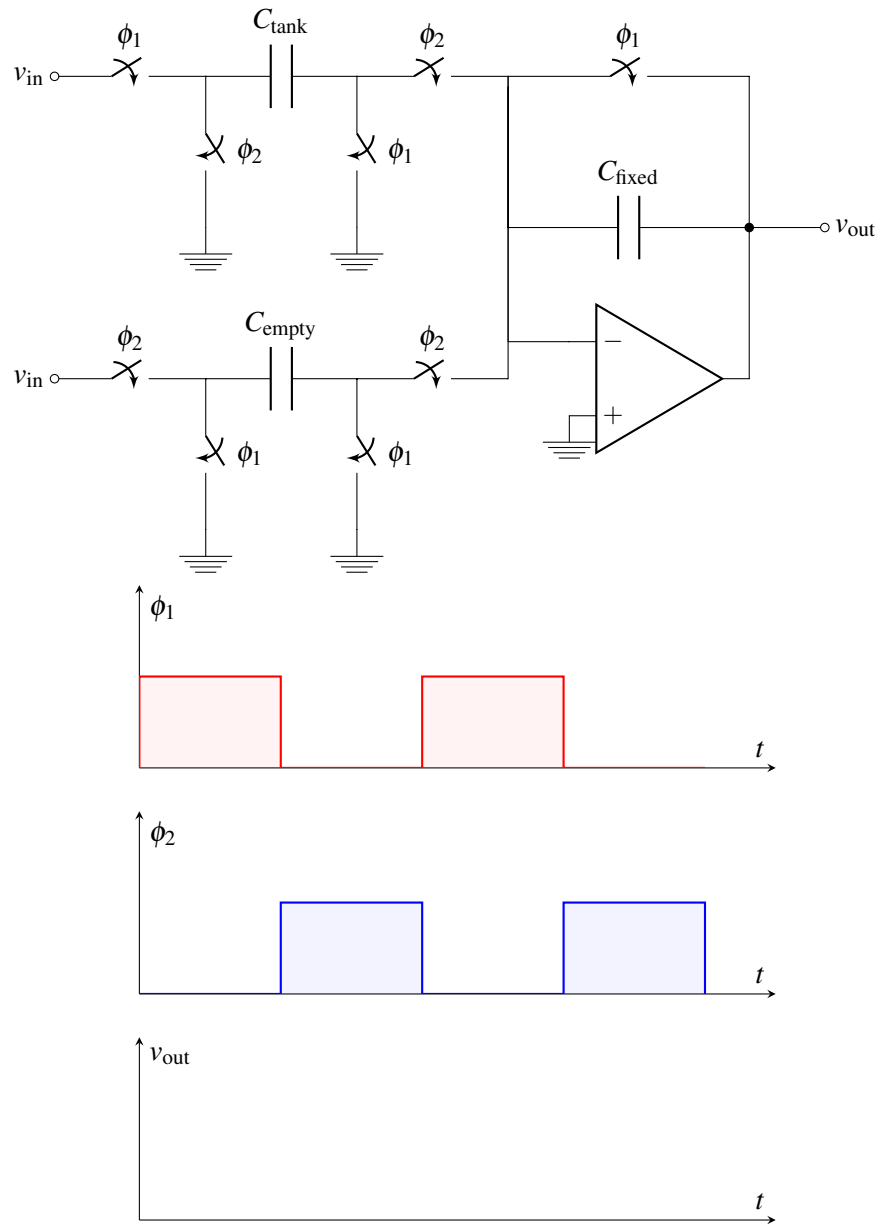

(e) Compare this version of the readout circuit to the previous version. Justify your choice.

### 5. Mechanical Correlation



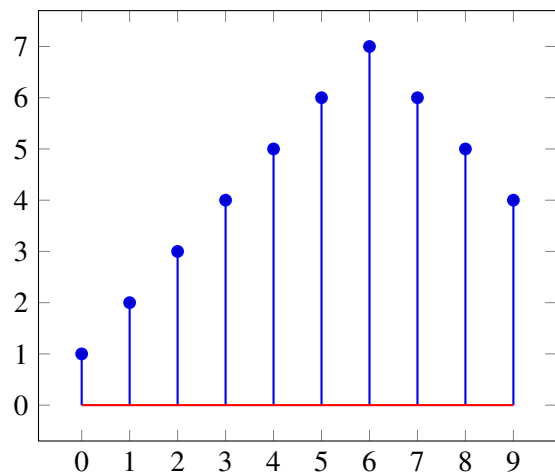
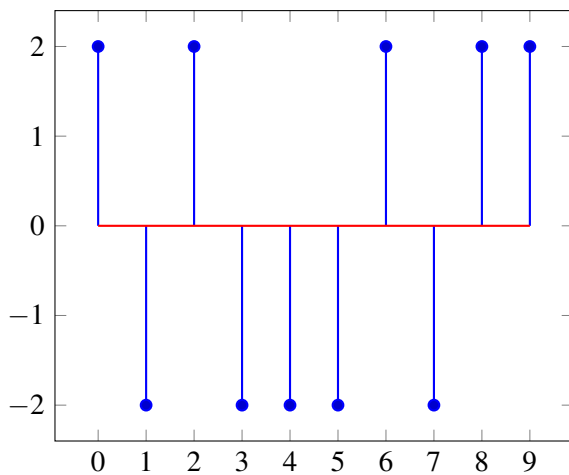

- (a) Calculate and plot the **autocorrelation** (the inner products of one period of the signal with all the possible shifts of one period of the same signal) of each of the above signals. Each signal is periodic with a period of 10 (one period is shown).
- (b) Calculate and plot the **cross-correlation** (the inner products of one period of the first signal with all possible shifts of one period of the second signal) of the two signals. Each signal is periodic with a period of 10 (one period is shown).

## 6. Homework Process

- (a) Who else did you work with on this homework? List names and student ID's. (In case of homework party, you can also just describe the group.) How did you work on this homework?  
Working in groups of 3-5 will earn you credit for your participation grade.
- (b) Copy the following statement into your homework submission.

I, [insert name here], affirm that all of my solutions are entirely my work and that I have properly credited and acknowledged any sources or work that I have consulted.