

EECS 16A Designing Information Devices and Systems I

Summer 2020 Homework 5B

This homework is due Sunday, August 2, 2020, at 23:59.

Self-grades are due Wednesday, August 5, 2020, at 23:59.

Submission Format

Your homework submission should consist of a single PDF file that contains all of your answers (any hand-written answers should be scanned).

Homework Learning Goals: *The objective of this homework is to present a variety of real-world circuit design problems that can be tackled using Op-Amp and switched capacitor circuits.*

1. PRACTICE: Integration using Op-amps

As we have seen already it is useful in several applications to create triangular voltages (also known as voltage ramps). Remember for instance the HW 8 problem where we built a circuit that could measure the level of water in a tank by “integrating” current on a capacitor whose value changed with the level of water in the tank. In this problem, you will be analyzing a circuit that produces a voltage ramp using a voltage source and an op-amp in negative feedback.

- (a) One of the circuit blocks you can use to generate the triangular waveform is the integrator. An integrator outputs the integral of the input signal. For the circuit given below express v_1 in terms of R_1 , C_1 , v_0 , and t , assuming v_0 is not varying with time. What is the slope of this voltage ramp? You may also assume that capacitor C_1 has $0V$ across it at time $t = 0$.

Hint: You will have to apply KCL, and use the fact that the current flowing through a capacitor is given by $I = C \frac{dV}{dt}$.

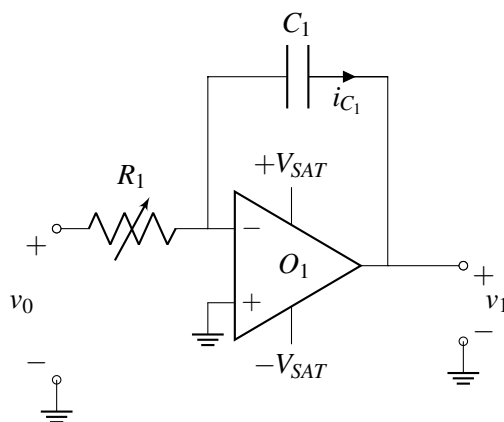

- (b) What is the value of the current i_{C_1} flowing through capacitor C_1 ? How does the capacitor current change if we double C_1 ? How does the slope of the ramp change if we double capacitor C_1 ?
Note: the current direction is specified in the figure above.
- (c) If we connect a load resistance at the output of the circuit, as shown in the figure below, does the output voltage v_1 change, from what you calculated in part (a)? Why or why not?

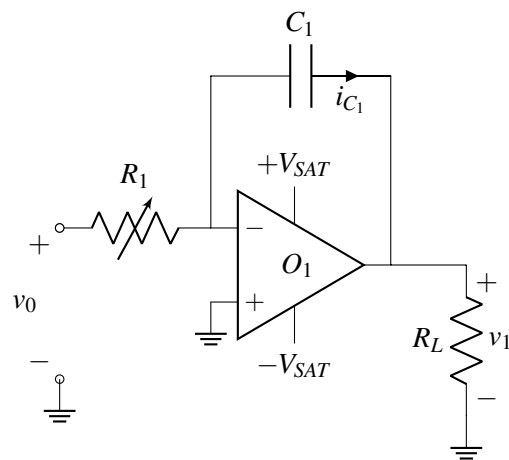

(d) If v_0 varies with time as shown in the following diagram, plot v_1 for $t = 0$ to $t = 1.5T$, where $T = 2T_h = 2T_l$. In your plot indicate an algebraic expression for the slope (as a function of R_1 , C_1 and v_{sq}) and add tick marks on the x and y axis indicating the time and voltage values where the ramp slope changes. You may assume again that capacitor C_1 has 0V across it at time $t = 0$.

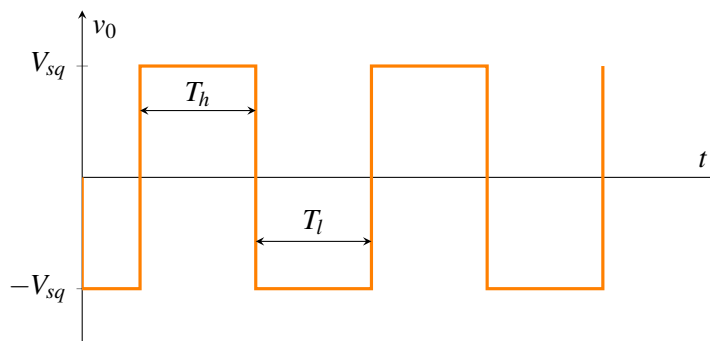

(e) **Practice (Optional):** Prove that the units of RC in SI are seconds.

2. PRACTICE: LED Alarm Circuit

One day, you come back to your dorm to find that your favorite candy has been stolen. Determined to catch the perpetrator red-handed, you decide to put the candy inside a kitchen drawer. Using the following circuit design, you would like to turn on a light-emitting diode (LED) “alarm” if the kitchen drawer is opened.

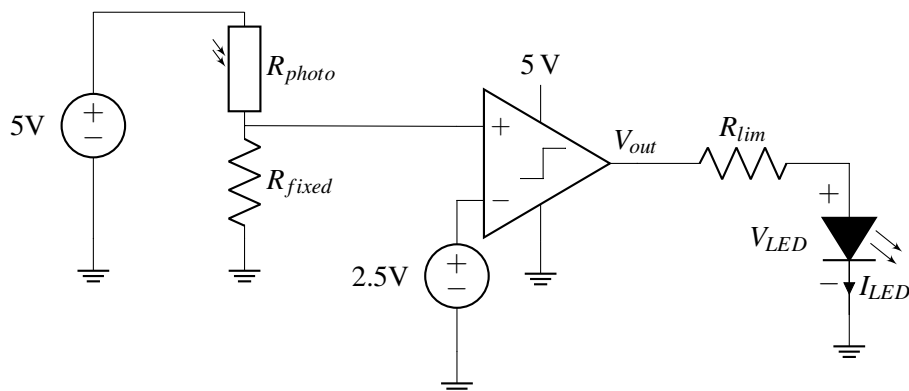

Note R_{photo} is a photoresistor, which acts like a typical resistor but changes resistance based on the amount of light it is exposed to. This photoresistor is located inside the kitchen drawer, so we can tell when the drawer is opened or closed.

V_{LED} indicates the voltage across the LED; we will guide you through the IV behavior of this element later in the problem. The LED is located in your room (and connected to a long wire going to the kitchen), so that you can remotely tell when the kitchen drawer has been opened.

(a) What is V_+ , the voltage at the positive voltage input of the comparator? Your answer should be written in terms of R_{photo} and R_{fixed} .

(b) We now want to choose a value for R_{fixed} . From the photoresistor's datasheet, we see the resistance in "light" conditions (i.e. drawer open) is $1\text{ k}\Omega$. In "dark" conditions (i.e. drawer closed), the resistance is $10\text{ k}\Omega$.

To ensure the comparator detects the light condition with more tolerance, we decide to design R_{fixed} so that V_+ is 3 V under the "light" condition. Solve for the value of R_{fixed} to meet this specification.

(c) Write down V_{out} with any conditions in terms of V_+ . For simplicity, consider the case when $V_+ \neq V_-$ and assume the comparator is ideal.

(d) Using your answers to the previous parts, write down V_{out} with the conditions on its output in terms of R_{photo} . You can substitute the value of R_{fixed} you found in part (b). As before, you can assume that $V_+ \neq V_-$ and the comparator is ideal.

(e) From the design steps in the previous parts, we have designed a circuit that outputs non-zero voltage when the photoresistor is exposed to light (i.e. kitchen drawer open). We now want to design the LED portion of the circuit, so we get a visual alarm when the drawer is open.

From the LED's datasheet, the forward voltage, V_F is 3 V . Essentially, if V_{LED} is less than this voltage, the LED won't light up and I_{LED} will be 0 A .

Here is an idealized IV curve of this LED. The LED behaves in one of the following two modes:

- i. If the voltage across the LED is less than $V_F = 3\text{ V}$ or if $I_{LED} < 0\text{ A}$, then the LED acts like an open circuit.
- ii. If the voltage across the LED is $V_F = 3\text{ V}$, then the LED acts like a voltage source, except that it only allows positive current flow (i.e. only in the direction of current marked on the circuit diagram).

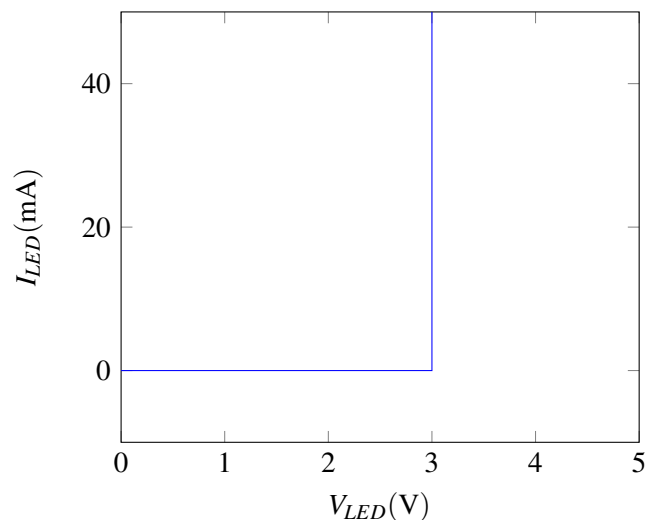

To avoid exceeding the power rating of the LED (and having it burn out), the recommended value for I_{LED} is 20 mA.

Find the value of the current-limiting resistor, R_{lim} , such that when the photoresistor is in the “light” condition, $I_{LED} = 20$ mA.

3. PRACTICE: Rain Sensor v2.0

In a previous homework, we analyzed a rain sensor built by a lettuce farmer in Salinas Valley. They used a rectangular tank outside and attached two metal plates to two opposite sides in an effort to make a capacitor whose capacitance varies with the amount of water inside. The width and length of the tank are both w (i.e. the base is square), and the height of the tank is h_{tot} .

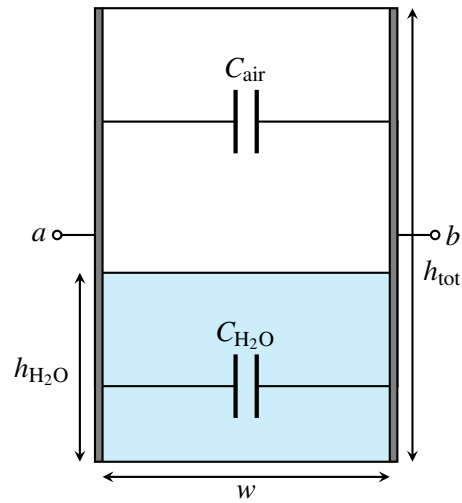

As your EE16A circuits toolkit is now complete with capacitors, op-amps, and switches, we will revisit this problem to improve the readout electronics. The goal is to create a circuit block that will output voltage as a linear function of the water height, h_{H_2O} .

- (a) What is the capacitance between terminals a and b when the tank is empty, C_{empty} ? Again, the height of the water in the tank is h_{H_2O} . Modeling the tank as a pair of capacitors in parallel, find the total capacitance C_{tank} between the two plates. Can you write C_{tank} as a function of C_{empty} ?

Note: The permittivity of air is ϵ , and the permittivity of rainwater is 81ϵ .

- (b) Here, we will analyze a circuit that transfers all charges for efficient readout. For the circuit below, draw the output waveform of v_{out} as a function of v_{in} , C_f , and C_{in} .

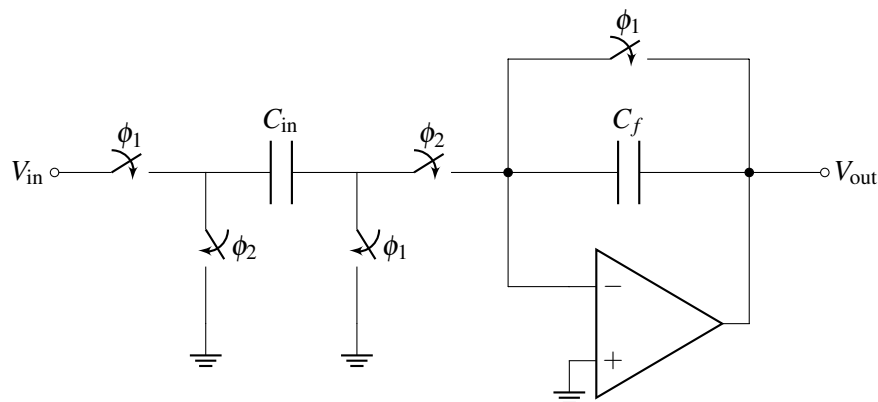

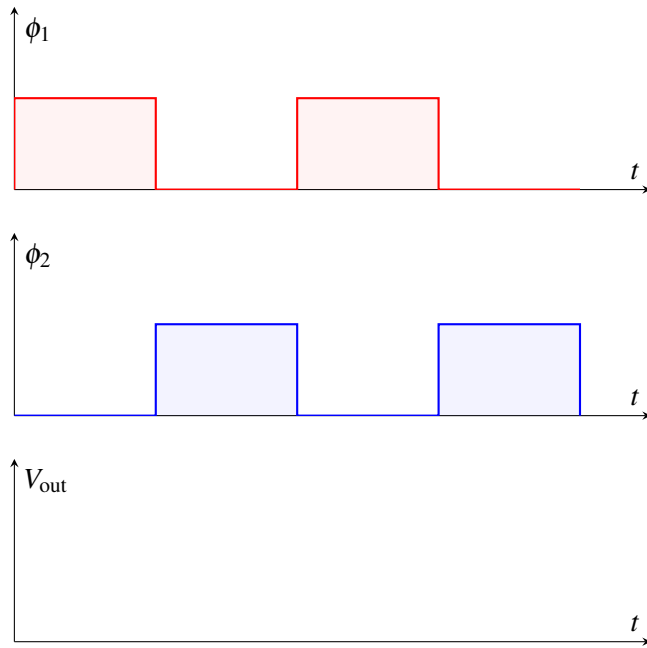

(c) We examined the non-inverting configuration in the previous part- now, we will look into the inverting configuration. For the circuit below, draw the output waveform of v_{out} as a function of v_{in} , C_f , and C_{in} .

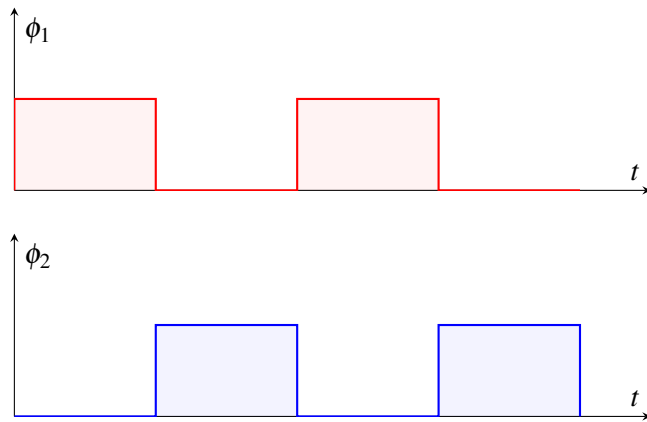
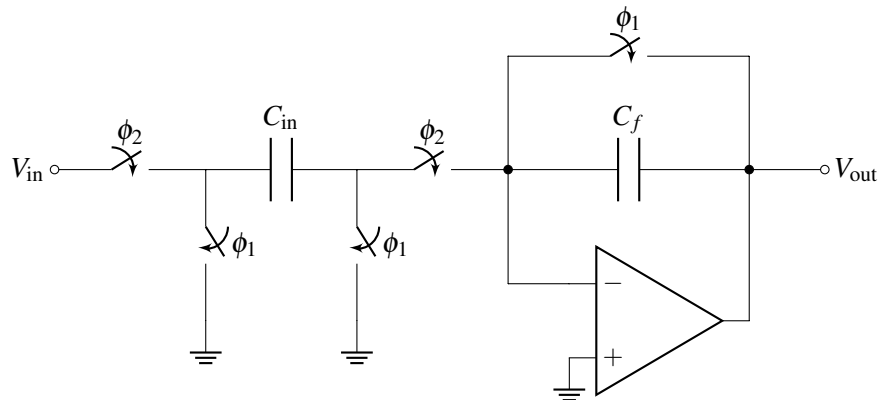



(d) With the help of the basic circuit blocks shown in parts (b) and (c), we will now implement a circuit that will output voltage as a linear function of the water height, h_{H_2O} . In addition to the rain-sensing capacitor, we will use two fixed value capacitors C_{fixed} and C_{empty} . Use the values obtained in part (a) for C_{tank} and C_{empty} . For the circuit below, draw the output waveform of v_{out} as a function of v_{in} , C_{fixed} , ϵ , and h_{H_2O} .

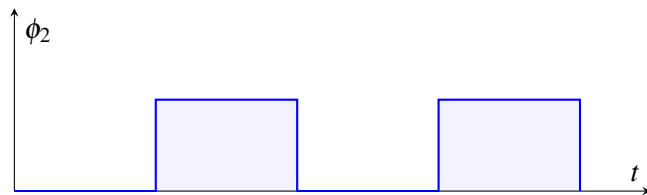
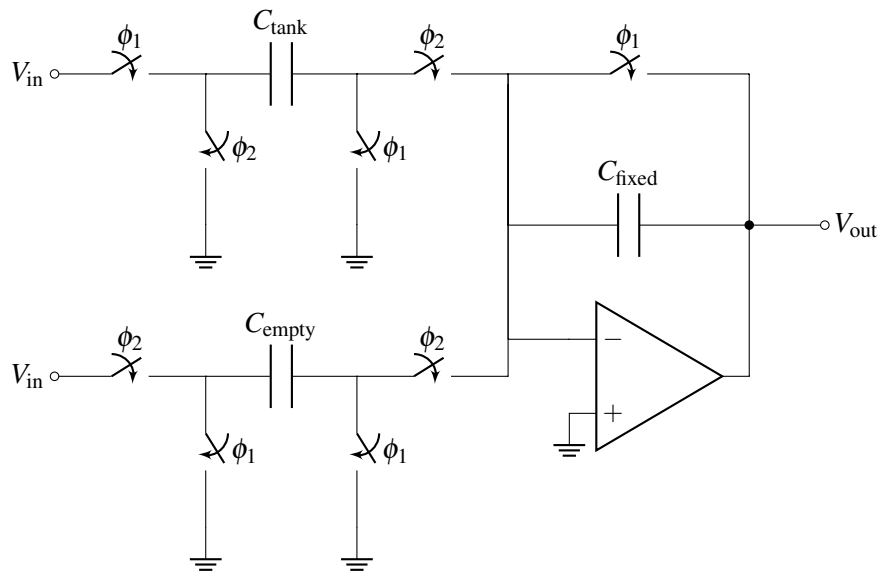

4. PRACTICE: Island Karaoke Machine

You're stuck on a desert island and everyone is bored out of their minds. Fortunately, you have your EE16A lab kit with op-amps, wires, resistors, and your handy breadboard. You decide to build a karaoke machine. You recover one speaker from the crash remains and use your iPhone as your source. You know that many songs put instruments on either the "left" or the "right" channel, but the vocals are usually present on both channels with equal strength.

The Thevenin equivalent model of the iPhone audio jack and speakers is shown below. We assume that the audio signals v_{left} and v_{right} have equivalent source resistance of the left/right audio channels of $R_{\text{left}} = R_{\text{right}} = 3\Omega$. The speaker has an equivalent resistance of $R_{\text{speaker}} = 4\Omega$.

For this problem, we'll assume that the vocals are present on both left and right channels, but the instruments are only present on the right channel, i.e.

$$v_{\text{left}} = v_{\text{vocals}}$$

$$v_{\text{right}} = v_{\text{vocals}} + v_{\text{instrument}},$$

where the voltage source v_{vocals} can have values anywhere in the range of $\pm 120\text{mV}$ and $v_{\text{instrument}}$ can have values anywhere in the range of $\pm 50\text{mV}$.

What is the goal of a karaoke machine? The ultimate goal is to *remove* the vocals from the audio output. We're going to do this by first building a circuit that takes the left and right audio outputs of the smartphone and then calculates its difference. Let's see what happens.

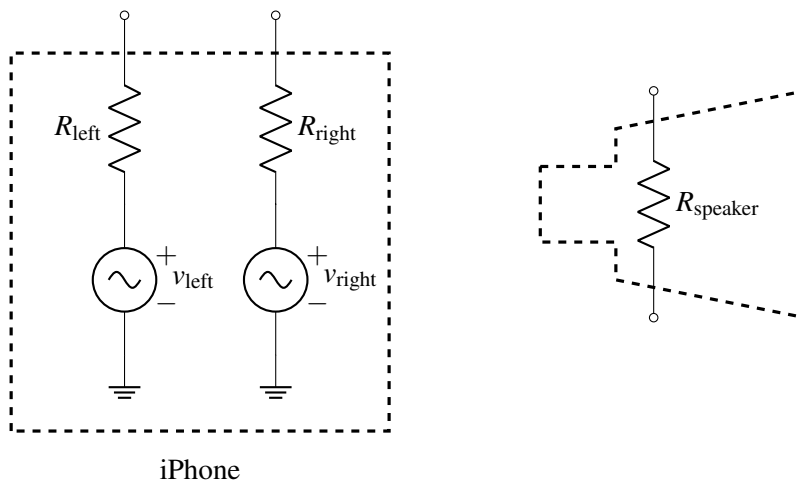

- (a) One of your island survivors suggests the following circuit to do this. Calculate the voltage across the speaker as a function of v_{vocals} and $v_{\text{instruments}}$. Does the voltage across the speaker depend on v_{vocals} ? What do you think the islanders will hear – vocals, instruments, or both?

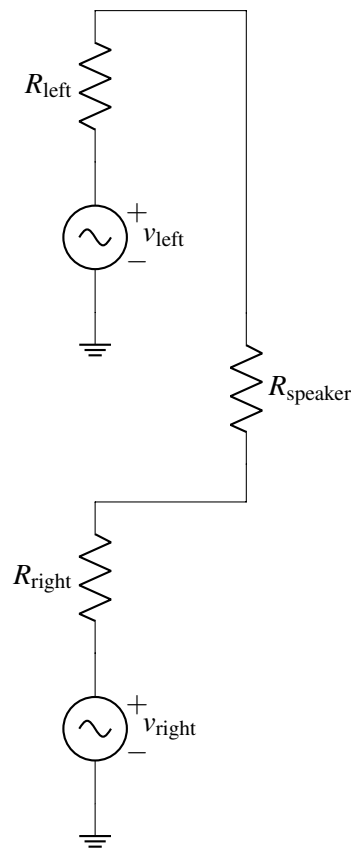

- (b) We need to boost the sound level to get the party going. We can do this by *amplifying* both v_{left} and v_{right} . Keep in mind that we could use inverting or non-inverting amplifiers. Let's assume, just for this part, that we have already implemented circuits that amplify v_{left} and v_{right} by some factor A_v (Consider $A_v = 100$ for this part). We now have two voltages, v_{Gl} and v_{Gr} that are $A_v \cdot v_{\text{left}}$ and $A_v \cdot v_{\text{right}}$ respectively. Use v_{Gl} and v_{Gr} to get $A_v \cdot v_{\text{instrument}}$ across R_{speaker} .
- (c) Now, you want $\pm 2 \text{ V}$ across the speaker to get the party going. Using the scheme in part (b), design a circuit that takes in v_{left} and v_{right} and outputs an amplified version of $v_{\text{instrument}}$ across the speaker with the range of $\pm 2 \text{ V}$. You need to design both amplifiers with the right gain A_v to achieve this. You can use up to two op-amps, and each of them can be inverting or non-inverting.
- (d) The trouble with the approach in part (c) is that multiple op-amps are required. Let's say you only have one op-amp with you. What would you do? One night in your dreams, you have an inspiration. Why not combine the inverting and non-inverting amplifier into one, as shown below!

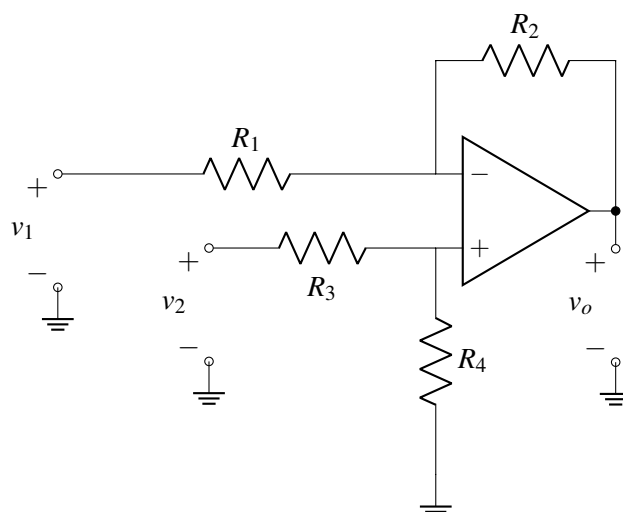

- If we set $v_2 = 0\text{V}$, what is the output v_o in terms of v_1 ? (This is the inverting path.)
- (e) If we set $v_1 = 0\text{V}$, what is the output v_o in terms of v_2 ? (This is the non-inverting path.)
- (f) Now, determine v_o in terms of v_1 and v_2 . (*Hint*: Use superposition.) Choose values for R_1 , R_2 , R_3 and R_4 , such that the speaker has $\pm 2\text{V}$ across it.

5. PRACTICE: Challenge Problem: Average

The circuit in Figure 1 below operates in time steps k , as illustrated in Figure 2. Each step is of duration T . During each step, switch S_2 is opened, and then switch S_1 is closed immediately afterwards. Then, after time $T/2$, switch S_1 is opened just before switch S_2 is closed.

At the end of each time step the input $V_{in}(kT)$ changes and the process repeats.

Derive an expression for $V_2(kT)$ as a function of $V_{in}(kT)$. Use $C_1 = pC_0$ and $C_2 = (1-p)C_0$.

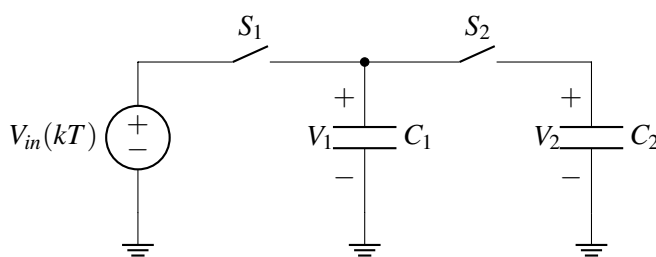

Figure 1: Averaging circuit

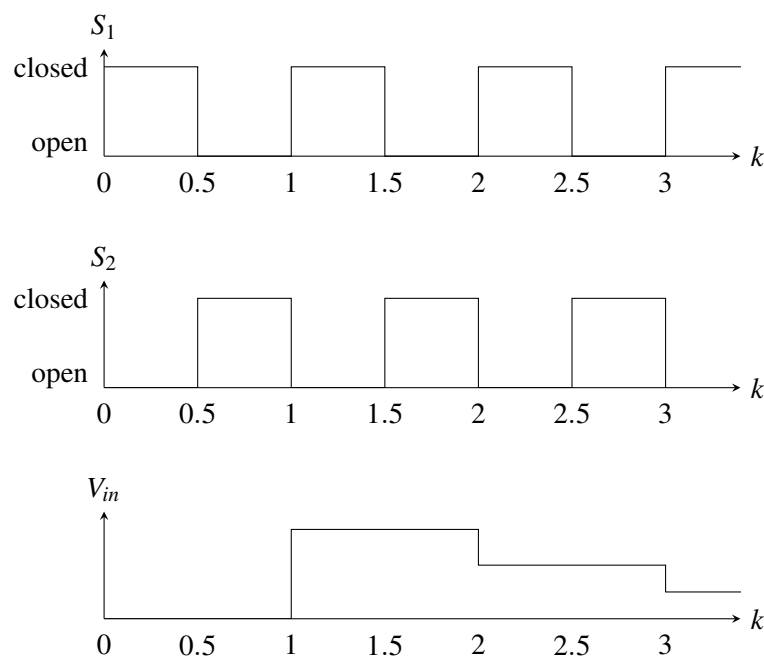

Figure 2: Timing diagram

—

6. MANDATORY - Not in scope for MT2: Cauchy-Schwarz Inequality

The Cauchy-Schwarz inequality states that for two vectors $\vec{v}, \vec{w} \in \mathbb{R}^n$:

$$\langle \vec{v}, \vec{w} \rangle = \vec{v}^T \vec{w} \leq \|\vec{v}\| \cdot \|\vec{w}\|$$

In this problem we will prove the Cauchy-Schwarz inequality for vectors in \mathbb{R}^2 .

Take two vectors: $\vec{v} = r \begin{bmatrix} \cos \theta \\ \sin \theta \end{bmatrix}$ and $\vec{w} = t \begin{bmatrix} \cos \phi \\ \sin \phi \end{bmatrix}$, where $r > 0, t > 0, \theta$, and ϕ are scalars. Make sure you understand why any vector in \mathbb{R}^2 can be expressed this way and why it is acceptable to restrict $r, t > 0$.

- In terms of some or all of the variables r, t, θ , and ϕ , what are $\|\vec{v}\|$ and $\|\vec{w}\|$?
- In terms of some or all of the variables r, t, θ , and ϕ , what is $\langle \vec{v}, \vec{w} \rangle$?
- Show that the Cauchy-Schwarz inequality holds for any two vectors in \mathbb{R}^2 .
- Note that the inequality states that the inner product of two vectors must be less than *or equal to* the product of their magnitudes. What conditions must the vectors satisfy for the equality to hold? In other words, when is $\langle \vec{v}, \vec{w} \rangle = \|\vec{v}\| \cdot \|\vec{w}\|$?

7. Homework Process and Study Group

Who else did you work with on this homework? List names and student ID's. (In case of homework party, you can also just describe the group.) How did you work on this homework?