

Read the following instructions before the exam.

Format & How to Submit Answers

There are 16 problems (4 introductory questions, and 12 exam questions, comprising 50 subparts total) of varying numbers of points. The problems are of varying difficulty, so pace yourself accordingly and avoid spending too much time on any one question until you have gotten all of the other points you can. Don't get bogged down in calculations; if you are having trouble with one problem, there may be easier points available later in the exam!

All answers will be submitted to the Gradescope "Final Exam" Assignment (<https://www.gradescope.com/courses/83747/assignments/500716>). All subparts, except introductory questions, are multiple choice and are **worth 3 points each**. **There are 145 points possible on the exam, but your final score will be taken out of 100 points.** This means that a score of 75/145, normally 51.7%, will be bumped up to 75/100, or 75%. You cannot score more than 100% on this exam.

Partial credit may be given for certain incorrect answer choices for some problems. There is no penalty for incorrect answers.

Post any content or clarifying questions privately on Piazza. There will be no exam clarifications; if we find a bug on the exam, that sub-question will be omitted from grading.

Timing & Penalties

You have 180 minutes for the exam, with a 5 minute grace period. After the 5 minute grace period ends, exam scores will be penalized exponentially as follows: an exam that is submitted N minutes after the end of the grace period will lose 2^N points. **The exam will become available at your personalized link at 8:10 am PT; the grace period will expire at 11:15 am PT.** If your submission is timestamped at 11:16 am PT, you will lose 2 points; if it is timestamped at 11:18 am PT, you will lose 8 points.

We will count the latest time at which you submit any question as your exam timestamp. Do NOT edit or resubmit your answers after the deadline. We recommend having all of your answers input and submitted by 11:10 am; it is your responsibility to submit the exam on time.

If you cannot access your exam at your link by 8:15 am, please email eeecs16a@berkeley.edu. If you are having technical difficulties submitting your exam, you can email your answers (either typed or scanned) to eeecs16a@berkeley.edu.

Academic Honesty

This is an open-note, open-book, open-internet, and **closed-neighbor** exam. You may use any calculator or calculation software that you wish, including Wolfram-Alpha and Mathematica. **No collaboration is allowed, and do not attempt to cheat in any way. Cheating will not be tolerated.**

We have zero tolerance against violation of the Berkeley Honor Code. Given supporting evidence of cheating, we reserve the right to automatically fail all students involved and report the instance to the student conduct committee. Feel free to report suspicious activity through this form. (<https://forms.gle/akhBsHVr1WG29Ufg9>).

Our advice to you: if you can't solve a particular problem, move on to another, or state and solve a simpler one that captures at least some of its essence. You will perhaps find yourself on a path to the solution.

Good luck!

EECS 16A Designing Information Devices and Systems I
Spring 2020 Final Exam

1. Pledge of Academic Integrity (2 points)

By my honor, I affirm that:

- (1) this document, which I will produce for the evaluation of my performance, will reflect my original, bona fide work;
- (2) as a member of the UC Berkeley community, I have acted and will act with honesty, integrity, and respect for others;
- (3) I have not violated—nor aided or abetted anyone else to violate—nor will I—the instructions for this exam given by the course staff, including, but not limited to, those on the cover page of this document; and
- (4) I have not committed, nor will I commit, any act that violates—nor aided or abetted anyone else to violate—the UC Berkeley Code of Student Conduct.

Write your name and the current date as an acknowledgement of the above. (See Gradescope)

2. Administrivia (1 point)

I know that I will lose 2^n points for every n minutes I submit after the exam submission grace period is over. For example, if the exam becomes available at my personalized link at 8:10 a.m. PT; the grace period will expire at 11:15 a.m. PT. If my submission is timestamped at 11:16 a.m. PT, I will lose 2 points; if it is timestamped at 11:18 a.m. PT, I will lose 8 points.

- Yes

3. What are you looking forward to this summer? (2 points)

4. Tell us about something that makes you happy. (2 points)

5. Matrix Properties (9 points)

What can you say about the following matrices? For each matrix that is given, '*' denotes a nonzero entry, while '0' denotes an entry equal to zero.

(a) Let the following matrix

$$A = \left[\begin{array}{ccc|c} * & 0 & * & * \\ 0 & 0 & * & 0 \\ 0 & * & 0 & * \\ 0 & 0 & * & * \end{array} \right]$$

be an augmented matrix that corresponds to a system of 4 linear equations in 3 unknowns. How many solutions does this system of equations have?

- (A) One solution
- (B) Not enough information to determine
- (C) No solutions
- (D) Infinitely many solutions

(b) Let the following matrix

$$B = \left[\begin{array}{ccc|c} * & * & * & * \\ 0 & * & 0 & * \\ 0 & 0 & * & * \\ 0 & 0 & 0 & * \end{array} \right]$$

be an augmented matrix that corresponds to a system of 4 linear equations in 3 unknowns. Select all that apply.

- (A) The 4×3 matrix corresponding to the original system of equations has a non-trivial nullspace
- (B) B is in reduced row echelon form
- (C) B is in row echelon form
- (D) B corresponds to a consistent set of linear equations

(c) Let the following matrix

$$C = \left[\begin{array}{cccc|c} * & * & 0 & * & * \\ 0 & * & * & * & 0 \\ 0 & * & * & * & 0 \\ 0 & 0 & 0 & 0 & 0 \end{array} \right]$$

be an augmented matrix that corresponds to a system of 4 linear equations in 4 unknowns. Which statements are guaranteed to be true? Select all that apply.

- (A) The system has exactly one basic variable
- (B) The system has exactly two free variables
- (C) The system has exactly one free variable
- (D) The system has exactly two basic variables
- (E) The system of equations is consistent

6. Splotchy Writing v2.0 (9 points)

It doesn't matter whether Professor Courtade writes in a sharpie or on an iPad, he still has terrible handwriting. The following is a (hypothetical) passage from lecture notes, and the smudges are labeled (1), (2), ..., (10). Your task is to identify correct expressions for some of the smudges.

The least squares solution derived in class was under the assumption that the norm $\|\cdot\|$ was the Euclidean one. However, if we are given an arbitrary inner product $\langle \cdot, \cdot \rangle$ on \mathbb{R}^n , we can still solve the least squares problem

$$\min_{\vec{x} \in \mathbb{R}^m} \|A\vec{x} - \vec{b}\|, \quad (1)$$

where $A \in \mathbb{R}^{(1) \times (2)}$ and $\vec{b} \in \mathbb{R}^{(3)}$ are given, and $\|\cdot\|$ is the norm on \mathbb{R}^n induced by the inner product $\langle \cdot, \cdot \rangle$. The key difference between this and the Euclidean setting is that we must introduce the so-called adjoint of A , denoted by A^* , which is the unique $(4) \times (5)$ matrix satisfying

$$(A^*\vec{y})^T \vec{x} = \langle \vec{y}, A\vec{x} \rangle$$

for all choices of vectors $\vec{x} \in \mathbb{R}^{(6)}$ and $\vec{y} \in \mathbb{R}^{(7)}$. In analogy to the Euclidean case, the solutions of the (non-Euclidean) least squares problem (??) are precisely those solutions to the system of "normal" equations

$$A^*A\vec{x} = A^*\vec{b}.$$

Using the fact that $N(A^*A) = N(A)$ (these are both subspaces of $\mathbb{R}^{(8)}$), we conclude that if $\text{rank}(A) = (9)$, then A^*A is invertible, and $\vec{x} = (A^*A)^{-1}A^*\vec{b} \in \mathbb{R}^{(10)}$ is the unique solution to the (non-Euclidean) least squares problem (??).

What is the correct value of each smudge below?

- (a) Smudge (3)
- (A) not enough information to determine
 - (B) m
 - (C) n
- (b) Smudge (6)
- (A) n
 - (B) not enough information to determine
 - (C) m
- (c) Smudge (8)
- (A) m
 - (B) n
 - (C) not enough information to determine

7. Vectors, matrices, and associated operations (12 points)

Consider the following vectors:

$$\vec{a} = \begin{bmatrix} 4 \\ 1 \\ 2 \end{bmatrix}, \vec{b} = \begin{bmatrix} 12 \\ 1 \\ 5 \end{bmatrix}, \vec{c} = \begin{bmatrix} -8 \\ 0 \\ -4 \end{bmatrix}, \vec{d} = \begin{bmatrix} -24 \\ -2 \\ -10 \end{bmatrix}, \vec{e} = \vec{b} - \text{proj}_{\vec{a}}(\vec{b}).$$

For each of the following subparts, select all statements that are true. Let $\langle \cdot, \cdot \rangle$ and $\|\cdot\|$ denote the usual Euclidean inner product and norm, respectively.

- (a) (A) $\|\vec{b}\| = \sqrt{170}$
 (B) $\langle \vec{a}, \vec{b} \rangle < \langle \vec{a}, \vec{c} \rangle < \langle \vec{a}, \vec{d} \rangle$
 (C) The sine of the angle between \vec{a} and \vec{b} equals $\frac{59}{\sqrt{170 \times 21}}$
 (D) The cosine of the angle between \vec{a} and \vec{b} equals $\frac{59}{\sqrt{170 \times 21}}$
 (E) \vec{a} and \vec{e} are orthogonal
 (F) $\|\vec{a}\| = 7$
 (G) \vec{a} and \vec{b} are orthogonal
- (b) Define the matrix

$$M_1 = \begin{bmatrix} | & | & | \\ \vec{a} & \vec{b} & \vec{d} \\ | & | & | \end{bmatrix}.$$

Similarly, define

$$M_2 = \begin{bmatrix} | & | \\ \vec{a} & \vec{b} \\ | & | \end{bmatrix} \text{ and } M_3 = \begin{bmatrix} | & | \\ \vec{b} & \vec{d} \\ | & | \end{bmatrix}.$$

- (A) M_2 is invertible
 (B) The dimensions of M_2 and M_3 are the same
 (C) $\text{rank}(M_1) = \text{rank}(M_3)$
 (D) M_1 is invertible
 (E) $\text{rank}(M_1) = \text{rank}(M_2)$
 (F) M_1, M_2, M_3 all have the same number of rows
 (G) $\lambda = 0$ is an eigenvalue of M_1

The vectors from before are repeated here for your convenience.

$$\vec{a} = \begin{bmatrix} 4 \\ 1 \\ 2 \end{bmatrix}, \vec{b} = \begin{bmatrix} 12 \\ 1 \\ 5 \end{bmatrix}, \vec{c} = \begin{bmatrix} -8 \\ 0 \\ -4 \end{bmatrix}, \vec{d} = \begin{bmatrix} -24 \\ -2 \\ -10 \end{bmatrix}, \vec{e} = \vec{b} - \text{proj}_{\vec{a}}(\vec{b}).$$

(c) Consider the following sets of vectors:

$$S_1 = \{\vec{a}, \vec{b}, \vec{c}\}, S_2 = \{\vec{a}, \vec{b}, \vec{d}\}, S_3 = \{\vec{a}, \vec{b}\}.$$

- (A) $\text{span}(S_1) = \text{span}(S_2)$
 - (B) $\text{span}(S_1)$ forms a basis for \mathbb{R}^3
 - (C) $\text{span}(S_2) = \text{span}(S_3)$
 - (D) $\text{span}(S_1) = \mathbb{R}^3$
 - (E) S_2 forms a basis for some subspace
- (d) Let $P, Q \in \mathbb{R}^{m \times m}$ be such that $QP = 0$. Let I denote the $m \times m$ identity matrix.
- (A) If $\det(Q) > 0$ then $\det(P) = 0$
 - (B) $PQ - Q(P - I) = 0$
 - (C) $\det(P) = 0$
 - (D) For $\lambda \in \mathbb{R}$, $\det(P^T Q^T + \lambda I) \neq 0$ if $\lambda \neq 0$

8. Visual Vectors (12 points)

(a) Each of the six panels below depicts a pair of two vectors, \vec{x} and \vec{y} in \mathbb{R}^2 (one drawn in red, the other in blue). Indicate which of these pairs of vectors, do we have that:

$$|\langle \vec{x}, \vec{y} \rangle| = \|\vec{x}\| \|\vec{y}\|,$$

where $\langle \cdot, \cdot \rangle$ is a given inner product on \mathbb{R}^2 , and $\|\cdot\|$ is the corresponding norm it induces.

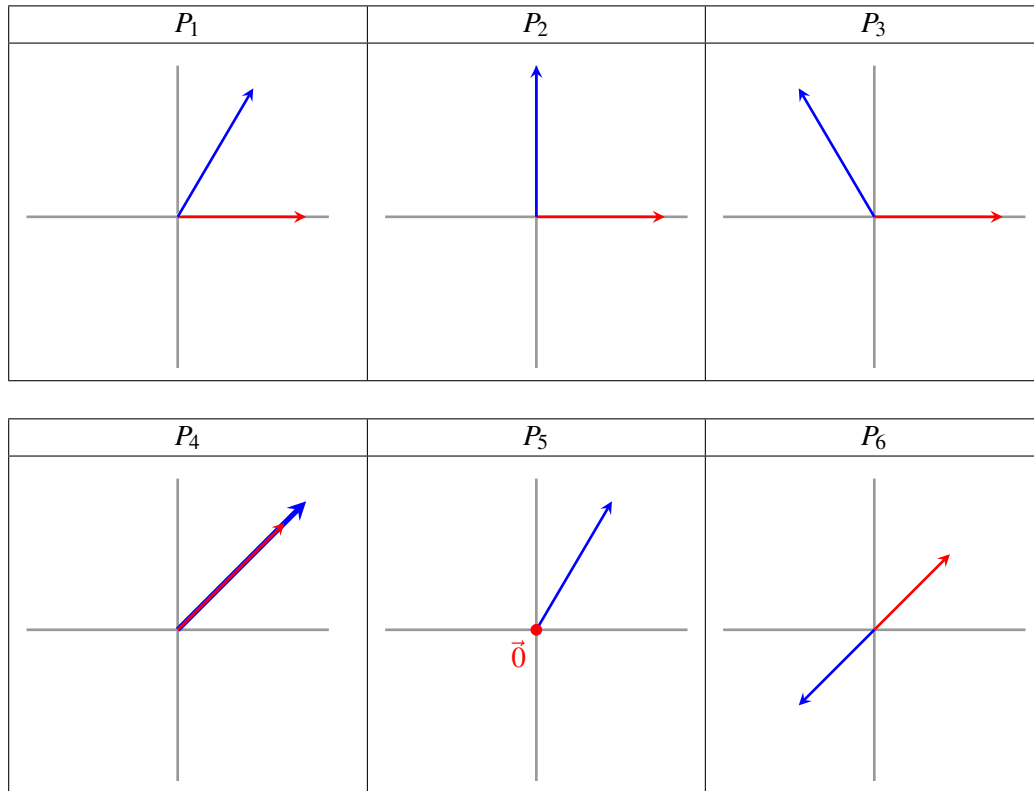

- (A) P_5
- (B) P_1, P_2, P_3
- (C) P_2, P_5
- (D) P_4, P_5, P_6
- (E) P_4, P_6

- (b) Let $\vec{e}_1 = \begin{bmatrix} 1 \\ 0 \end{bmatrix}$ and $\vec{e}_2 = \begin{bmatrix} 0 \\ 1 \end{bmatrix}$ denote the natural basis vectors in \mathbb{R}^2 . For a given matrix M , the vectors $M\vec{e}_1$ and $M\vec{e}_2$ are drawn in the plot below. What is the determinant of the matrix M ?

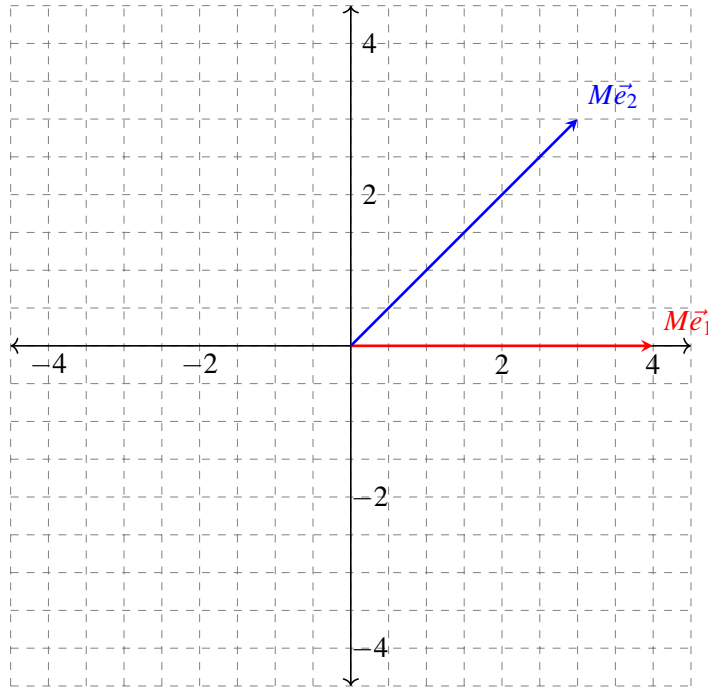

- (A) 0.0
- (B) 6.0
- (C) 7.0
- (D) -24.0
- (E) 24.0
- (F) 12.0

(c) You are given the matrices

$$P = \begin{bmatrix} \frac{1}{\sqrt{2}} & -\frac{1}{\sqrt{2}} \\ \frac{1}{\sqrt{2}} & \frac{1}{\sqrt{2}} \end{bmatrix} \quad \text{and} \quad S = \begin{bmatrix} \frac{1}{2} & 0 \\ 0 & 1 \end{bmatrix}$$

Choose the correct illustration of vectors \vec{v}, \vec{w} defined according to

$$\vec{v} = PS^2 \begin{bmatrix} 1 \\ 0 \end{bmatrix} \quad \text{and} \quad \vec{w} = PS^2 \begin{bmatrix} 0 \\ 1 \end{bmatrix}.$$

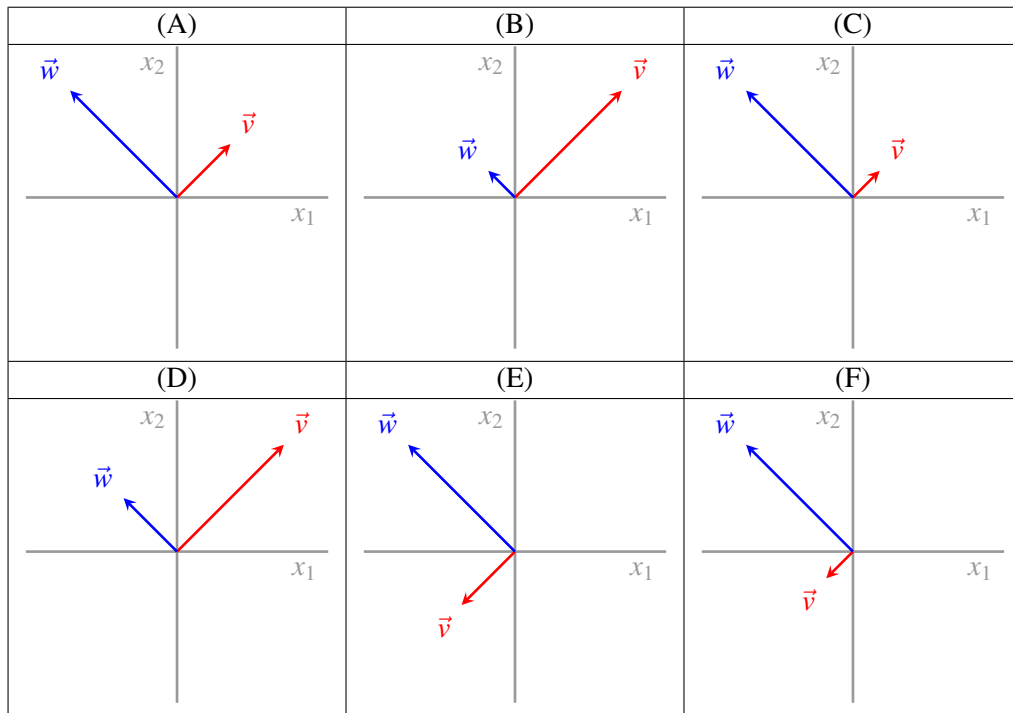

(d) Below you are given three plots P_1 , P_2 , and P_3 with corresponding vectors \vec{v}_1 , \vec{v}_2 , and \vec{v}_3 drawn on each. For reference, the vectors \vec{a} , \vec{b} are the same in all three plots. Choose the option that correctly expresses the \vec{v}_i 's as one of \vec{b} , $\text{proj}_{\vec{a}}(\vec{b})$, or $\vec{b} - \text{proj}_{\vec{a}}(\vec{b})$. You should assume that projections are taken with respect to the Euclidean inner product.

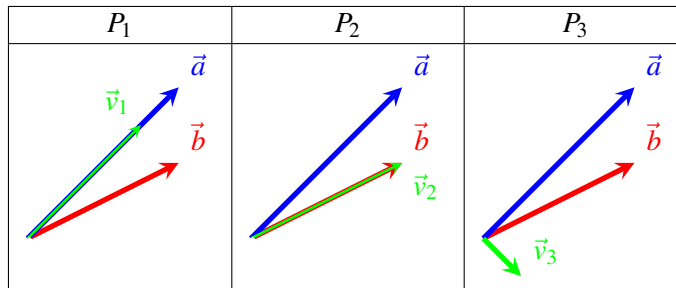

- (A) $\vec{v}_1 = \text{proj}_{\vec{a}}(\vec{b})$, $\vec{v}_2 = \vec{b}$, $\vec{v}_3 = \vec{b} - \text{proj}_{\vec{a}}(\vec{b})$
- (B) $\vec{v}_1 = \vec{b} - \text{proj}_{\vec{a}}(\vec{b})$, $\vec{v}_2 = \text{proj}_{\vec{a}}(\vec{b})$, $\vec{v}_3 = \vec{b}$
- (C) $\vec{v}_1 = \text{proj}_{\vec{a}}(\vec{b})$, $\vec{v}_2 = \vec{b} - \text{proj}_{\vec{a}}(\vec{b})$, $\vec{v}_3 = \vec{b}$.
- (D) $\vec{v}_1 = \vec{b} - \text{proj}_{\vec{a}}(\vec{b})$, $\vec{v}_2 = \vec{b}$, $\vec{v}_3 = \text{proj}_{\vec{a}}(\vec{b})$
- (E) $\vec{v}_1 = \vec{b}$, $\vec{v}_2 = \text{proj}_{\vec{a}}(\vec{b})$, $\vec{v}_3 = \vec{b} - \text{proj}_{\vec{a}}(\vec{b})$.
- (F) $\vec{v}_1 = \vec{b}$, $\vec{v}_2 = \vec{b} - \text{proj}_{\vec{a}}(\vec{b})$, $\vec{v}_3 = \text{proj}_{\vec{a}}(\vec{b})$

9. Nodes and Loops (15 points)

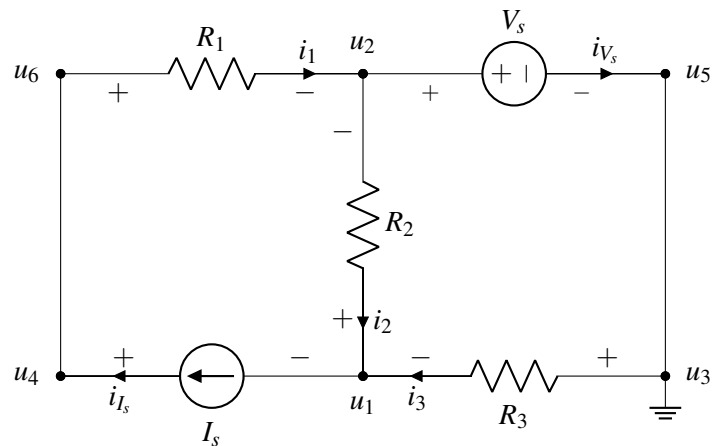

- (a) Select all elements of the circuit that have current-voltage labeling that violates passive sign convention:
- (b) There are more node labelings (u_1, \dots, u_6) than necessary. Select all node pairings that describe the same node.
- (A) u_6, u_4
- (B) u_6, u_2
- (C) u_2, u_1
- (D) u_5, u_3
- (E) u_4, u_1
- (c) Select the equation for current-voltage relationship of R_1 in terms of resistance, current and node voltages.

The circuit on the previous page is repeated here for your convenience.

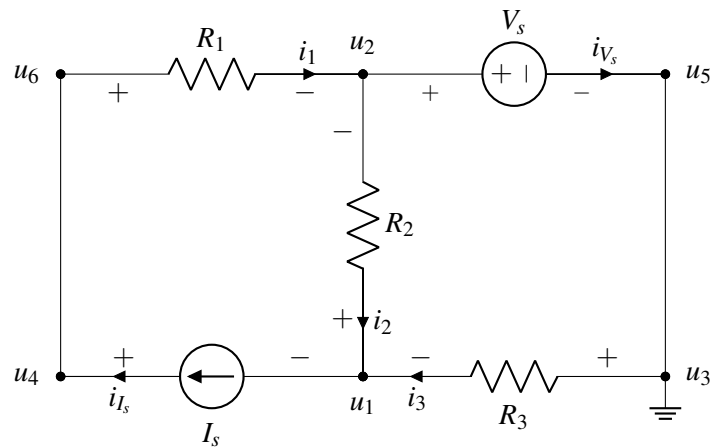

- (d) Write the KCL equation for the currents associated with node u_2 in terms of i_1 , i_2 , i_3 , i_4 , i_{I_s} and i_{V_s} .
- (e) Using $V_s = 4\text{ V}$, $I_s = 5\text{ A}$, $R_1 = 2\ \Omega$, $R_2 = 3\ \Omega$, and $R_3 = 2\ \Omega$, find the value of i_2 .

10. Scissor, Chisel or Knife: What should I use? (12 points)

Consider the following constrained least squares problem:

$$\min_{\vec{x}} \|A\vec{x} - \vec{b}\| \quad \text{subject to } \|\vec{x}\|_0 \leq k.$$

Each of the following subparts (a)-(e) specifies A , \vec{b} and k . Your task is to determine which of the three methods you have learned about in EECS16A (Gaussian Elimination, Least Squares and/or OMP), could be used for solving the constrained least squares problem given the problem instance. **You should select all methods that can be reasonably applied to solve the problem.**

For purposes of this problem:

- “Least Squares” is intended to mean evaluating the solution explicitly as:

$$\vec{x}^* = (A^T A)^{-1} A^T \vec{b}.$$

- You should not rule out using OMP simply because columns of A do not have equal norms. Recall that this was only a simplifying assumption that was made without any loss of generality. Any implementation of OMP would incorporate a preliminary step where the columns of A were rescaled to have norm one.

(a)

$$A = \begin{bmatrix} 0 & 0 & 6 & 0 \\ 3 & 0 & 0 & 0 \\ 0 & 0 & 0 & -2 \\ 0 & 1 & 0 & 0 \end{bmatrix}, \quad \vec{b} = \begin{bmatrix} 1 \\ 7 \\ 9 \\ -1 \end{bmatrix}, \quad k = 4.$$

- (A) Gaussian Elimination can be applied.
 (B) Least Squares can be applied.
 (C) OMP can be applied.

(b)

$$A = \begin{bmatrix} 1 & 2 & 3 \\ 0 & 4 & 4 \\ 2 & 0 & 2 \\ 9 & 6 & 15 \end{bmatrix}, \quad \vec{b} = \begin{bmatrix} 9 \\ 12 \\ 6 \\ 45 \end{bmatrix}, \quad k = 3.$$

- (A) Gaussian Elimination can be applied.
 (B) Least Squares can be applied.
 (C) OMP can be applied.

(c)

$$A = \begin{bmatrix} 1 & 0 & 0 \\ 0 & 0 & 1 \\ 0 & 0 & 0 \\ 0 & 1 & 0 \end{bmatrix}, \quad \vec{b} = \begin{bmatrix} 3 \\ 2 \\ 0.1 \\ 4 \end{bmatrix}, \quad k = 3.$$

- (A) Gaussian Elimination can be applied.
- (B) Least Squares can be applied.
- (C) OMP can be applied.

(d)

$$A = \begin{bmatrix} 0 & 0 & 0 & 0 \\ 0 & 1 & 0 & 2 \\ 2 & 0 & 1 & 0 \end{bmatrix}, \quad \vec{b} = \begin{bmatrix} 0.25 \\ 6 \\ 8 \end{bmatrix}, \quad k = 2.$$

- (A) Gaussian Elimination can be applied.
- (B) Least Squares can be applied.
- (C) OMP can be applied.

11. Best Quadratic Fit (3 points)

You are given vectors \vec{x} and \vec{y} defined as follows

$$\vec{x} = [1 \quad 3 \quad -4 \quad 3 \quad -5]^T, \quad \vec{y} = [13 \quad -2 \quad 7 \quad -7 \quad 4]^T.$$

To two decimal places of precision, determine scalars $a, b \in \mathbb{R}$ such that the error in the approximation

$$ax_i^2 + b \approx y_i, \quad i = 1, 2, \dots, 5$$

is minimized in the sense of least squares (a calculator will be helpful).

- (A) $a = 2.62, b = -0.95$
- (B) $a = -0.95, b = 2.62$
- (C) $a = 4.33, b = -0.11$
- (D) $a = -0.95, b = 0.00$
- (E) $a = -0.11, b = 4.33$

12. Non-Ideal Voltage Source (15 points)

Consider the following circuit and waveforms. Note that the waveforms are not drawn to scale.

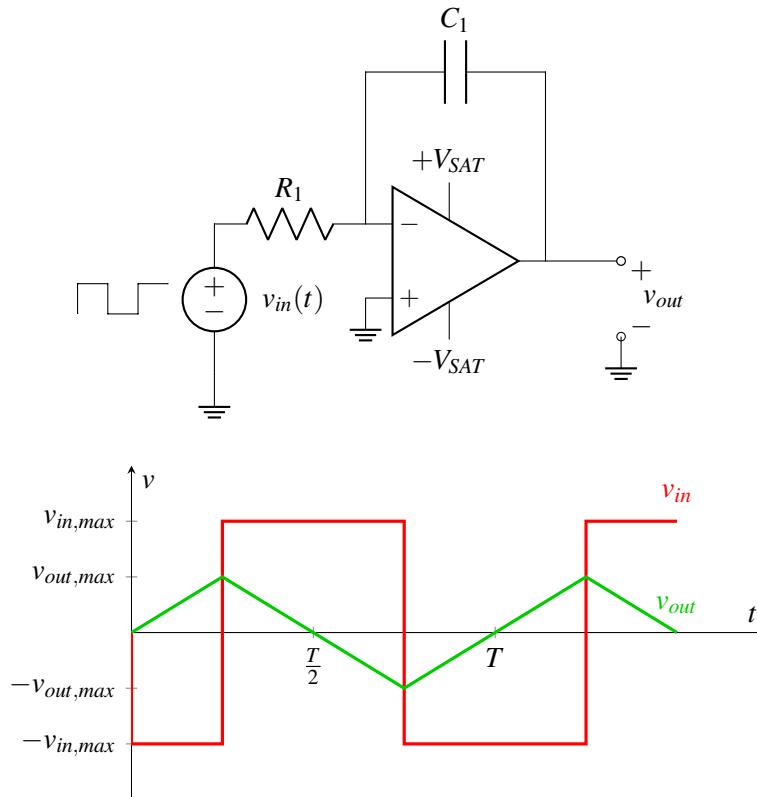

- (a) Assume that v_{in} is an ideal voltage source that outputs a square wave with amplitude $v_{in,max} = 5\text{ V}$ and period $T = 2\text{ ms}$, and recall that v_{out} will be a triangle wave with peak value $v_{out,max}$. Both waveforms are plotted in the diagram above. If $R_1 = 2\text{ k}\Omega$, $C_1 = 3\text{ }\mu\text{F}$, and $V_{SAT} = 5\text{ V}$, what will be the peak value $v_{out,max}$ of our output?

- (b) Real power supplies cannot act as ideal voltage sources; instead, they have an associated output resistance. Consider the following model of a “real” voltage source. Note: this circuit is separate from part a) for this question.

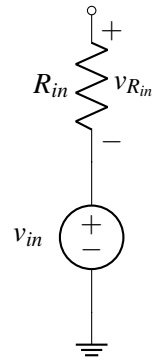

If $R_{in} = 700\ \Omega$, what is $v_{R_{in}}$, the voltage drop across R_{in} ?

- (c) Now, suppose we modify our earlier circuit model to include this source resistance. Our new circuit diagram is shown below.

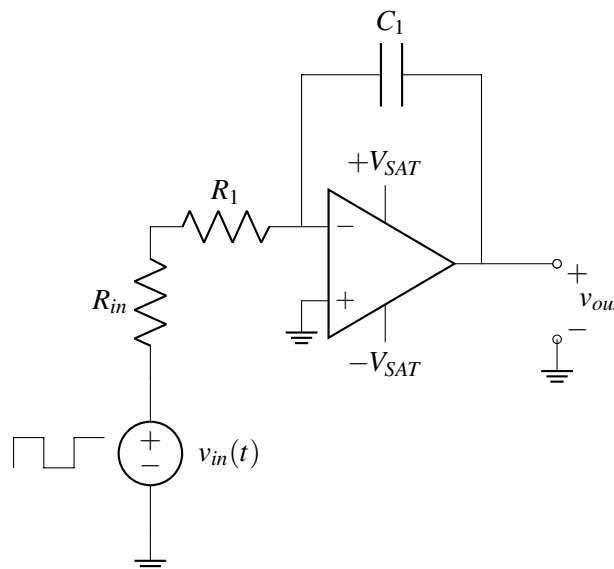

Assuming all parameters remain the same as in previous subparts, what is the new peak output voltage $v_{out,max}$?

- (d) To compensate for the effects of this source resistance, you decide to modify the capacitor value. You can add one capacitor to your circuit, either in series or in parallel with the existing capacitor C_1 . Which of the following configurations will result in a triangle-wave output identical to that in part (a)?
- (e) Consider the following circuit:

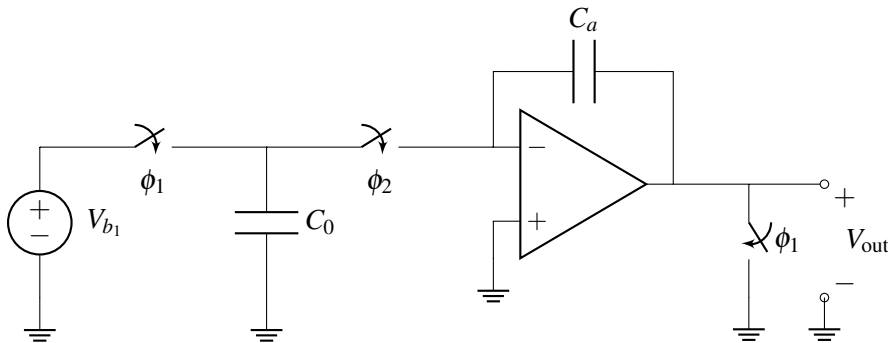

During phase 1, ϕ_1 is closed and ϕ_2 is open. During phase 2, ϕ_1 is open and ϕ_2 is closed. What is the voltage V_{out} during phase 1 and phase 2? You can assume that a long time has passed in each phase before V_{out} is measured.

13. Pagerank with a twist (15 points)

Consider the following pagerank setup that we have encountered before. In this simplified setting, there are only 2 websites - Facebook (F) and Reddit (R). At time $n \geq 0$, denote our state by

$$\vec{x}[n] = \begin{bmatrix} x_F[n] \\ x_R[n] \end{bmatrix}$$

Here, $x_F[n]$ denotes the number of users on Facebook at time n and $x_R[n]$ denotes the number of users on Reddit at time n . The dynamics of the state evolution is modeled as

$$\vec{x}[n+1] = S\vec{x}[n] \quad \text{for } n \geq 0; \quad S = \begin{bmatrix} w_{FF} & w_{RF} \\ w_{FR} & w_{RR} \end{bmatrix}. \quad (2)$$

However, we do not know the entries of the S matrix, and that is what we are tasked with finding.

(a) Choose the appropriate matrix A from the options for the system of equations below.

$$A \underbrace{\begin{bmatrix} w_{FF} \\ w_{RF} \\ w_{FR} \\ w_{RR} \end{bmatrix}}_{\vec{w}} = \underbrace{\begin{bmatrix} x_F[1] \\ x_R[1] \\ \vdots \\ x_F[T] \\ x_R[T] \end{bmatrix}}_{\vec{b}} \quad (3)$$

(A)

$$\begin{bmatrix} x_F[0] & x_R[0] & x_F[0] & x_R[0] \\ x_F[0] & x_R[0] & x_F[0] & x_R[0] \\ \vdots & \vdots & \vdots & \vdots \\ x_F[T-1] & x_R[T-1] & x_F[T-1] & x_R[T-1] \\ x_F[T-1] & x_R[T-1] & x_F[T-1] & x_R[T-1] \end{bmatrix}$$

(B)

$$\begin{bmatrix} x_F[0] & x_R[0] & 0 & 0 \\ 0 & 0 & x_F[1] & x_R[1] \\ \vdots & \vdots & \vdots & \vdots \\ x_F[T-1] & x_R[T-1] & 0 & 0 \\ 0 & 0 & x_F[T] & x_R[T] \end{bmatrix}$$

(C)

$$\begin{bmatrix} x_F[0] & x_R[0] & 0 & 0 \\ 0 & 0 & x_F[0] & x_R[0] \\ \vdots & \vdots & \vdots & \vdots \\ x_F[T-1] & x_R[T-1] & 0 & 0 \\ 0 & 0 & x_F[T-1] & x_R[T-1] \end{bmatrix}$$

(D)

$$\begin{bmatrix} 0 & 0 & x_F[0] & x_R[0] \\ x_F[0] & x_R[0] & 0 & 0 \\ \vdots & \vdots & \vdots & \vdots \\ 0 & 0 & x_F[T-1] & x_R[T-1] \\ x_F[T-1] & x_R[T-1] & 0 & 0 \end{bmatrix}$$

(E)

$$\begin{bmatrix} x_F[0] & x_R[0] & -x_F[0] & -x_R[0] \\ -x_F[0] & -x_R[0] & x_F[0] & x_R[0] \\ \vdots & \vdots & \vdots & \vdots \\ x_F[T-1] & x_R[T-1] & -x_F[T-1] & -x_R[T-1] \\ -x_F[T-1] & -x_R[T-1] & x_F[T-1] & x_R[T-1] \end{bmatrix}$$

(b) For $T = 1$, is the system (??) consistent? And if yes, does it have a unique solution? Choose the option which best answers the question.

- (A) Consistent system, unique solution if and only if $\vec{x}[0]$ is not an eigenvector of S
- (B) Consistent system, unique solution if and only if $\vec{x}[0]$ is not a steady state vector of S
- (C) Inconsistent system
- (D) Consistent system, has a unique solution
- (E) Consistent system, has infinite solutions

(c) For $T = 2$, is the system (??) consistent? And if yes, does it have a unique solution? Choose the option which best answers the question.

- (A) Consistent system, has a unique solution
- (B) Consistent system, unique solution if and only if $\vec{x}[0]$ is not a steady state vector of S
- (C) Consistent system, unique solution if and only if $\vec{x}[0]$ is not an eigenvector of S
- (D) Inconsistent system
- (E) Consistent system, has infinite solutions

(d) Now, suppose we do not observe the states $\vec{x}[n]$ directly, but instead we are provided with imperfect estimates of the system state up to timestep T . That is, we are given the collection of vectors $\{\vec{y}[0] \dots \vec{y}[T]\}$, where $\vec{y}[i]$ is a noisy observation of the state $\vec{x}[i]$ at time i . Hence, we replace all values of $x_F[i]$ and $x_R[i]$ with $y_F[i]$ and $y_R[i]$, respectively, in the definitions of A, \vec{b} in (??). You discover that the resulting system of equations is inconsistent and that matrix A has linearly independent columns.

What is the best procedure to find \vec{w}^* that minimizes the error $\|A\vec{w} - \vec{b}\|$?

- (A) Use Least Squares, $\vec{w}^* = (A^T A)^{-1} A^T b$
- (B) Use Orthogonal Matching Pursuit, $\vec{w}^* = (S^T S)^{-1} S^T b$
- (C) Use Least Squares, $\vec{w}^* = (S^T S)^{-1} S^T b$
- (D) Use Orthogonal Matching Pursuit, $\vec{w}^* = (A^T A)^{-1} A^T b$
- (E) Use Gaussian Elimination

(e) You apply the procedure you selected in the previous part and obtain

$$\vec{w}^* = \begin{bmatrix} 0.3 \\ 0.5 \\ 0.7 \\ 0.5 \end{bmatrix}.$$

Now that you have an approximate solution for the unknown state transition matrix S , you can attempt to answer questions about the pagerank evolution in System (??). Does System (??) have a steady state and does $\lim_{n \rightarrow \infty} S^n \vec{x}[n]$ converge for all choices of $\vec{x}[0]$? Choose the option which best answers the question.

- (A) Does not have a steady state, may not converge
- (B) Has a steady state, may not converge
- (C) Has a steady state, always converges
- (D) Does not have a steady state, always converges

14. Matching Pursuit (9 points)

Consider the constrained least squares problem

$$\min_{\vec{x} \in \mathbb{R}^5} \|M\vec{x} - \vec{b}\| \quad \text{subject to: } \|\vec{x}\|_0 \leq k.$$

In the above, the matrix M and the vector \vec{b} are given by:

$$M = \begin{bmatrix} \sqrt{1/5} & 0 & \sqrt{1/2} & \sqrt{1/4} & \sqrt{1/3} \\ \sqrt{4/5} & 1 & \sqrt{1/2} & \sqrt{3/4} & \sqrt{2/3} \end{bmatrix}, \quad \vec{b} = \begin{bmatrix} 7 \\ 9 \end{bmatrix}.$$

- (a) If we ran Matching Pursuit for one iteration, which coordinates of the resulting solution $\vec{x} = [x_1, x_2, \dots, x_5]^T$ would be nonzero? Select all that apply.
- (A) x_1
 - (B) x_2
 - (C) x_3
 - (D) x_4
 - (E) x_5
- (b) If we ran Matching Pursuit for two iterations, which coordinates of the resulting solution $\vec{x} = [x_1, x_2, \dots, x_5]^T$ would be nonzero? Select all that apply.
- (A) x_1
 - (B) x_2
 - (C) x_3
 - (D) x_4
 - (E) x_5
- (c) If we ran Orthogonal Matching Pursuit for two iterations, what would be the norm of the resulting residual $\vec{e} = \vec{b} - M\vec{x}$? Choose the option which best answers the question.
- (A) $\|\vec{e}\|^2 = 3$
 - (B) $\|\vec{e}\|^2 = 1$
 - (C) $\|\vec{e}\|^2 = 4$
 - (D) $\|\vec{e}\|^2 = 0$
 - (E) $\|\vec{e}\|^2 = 2$

15. Building a Noise-Resistant Comparator (18 points)

In many sensing applications in which you are trying to distinguish between two states (for example determining if a light is on or off, or if it's hot or cold) the output of a comparator is often used as a function of time. However, in many situations there is significant noise in the circuit which can lead to false transitions between the states. In this problem, we will explore the pitfalls of simply using a comparator and see how to remedy the situation.

We will be analyzing a hypothetical sensing application where the on-state occurs when the input voltage is positive and the off-state occurs when the input voltage is negative.

- (a) Select the comparator circuit that would output V_{DD} when the system is in the on-state and V_{SS} when it is in the off state. Let v_s be the input signal.

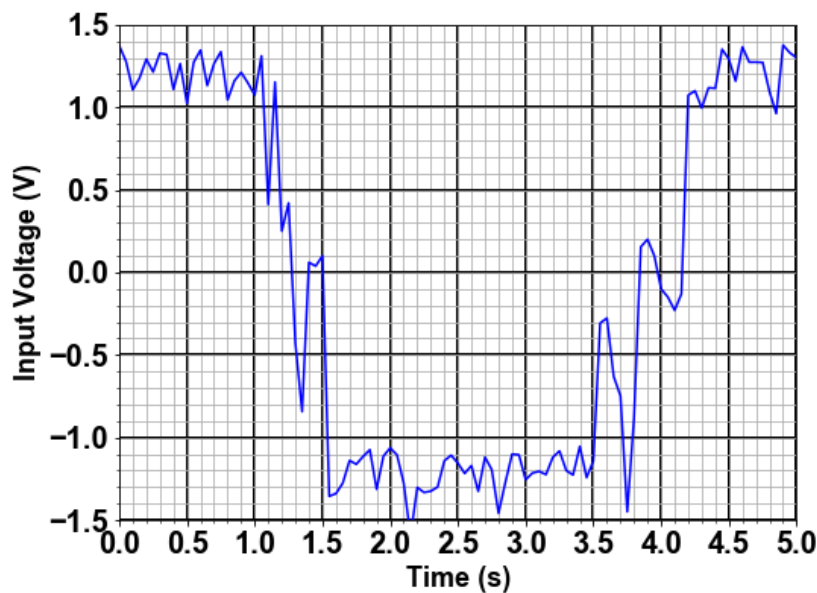
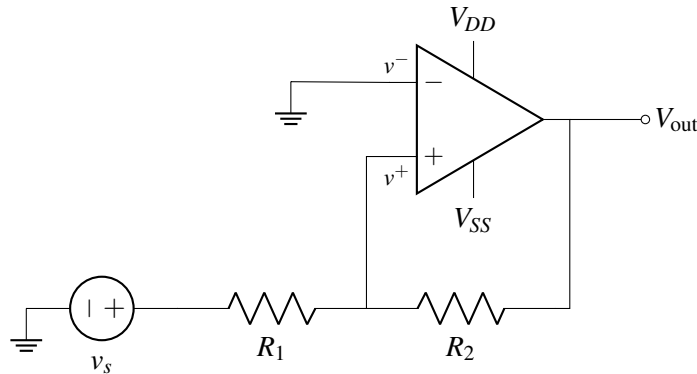

Figure 1: Noisy input signal

- (b) Now consider the above noisy input signal. Determine the total number of times the output of the comparator switches between V_{DD} and V_{SS} .

- (c) Seeing that a simple comparator circuit will not do the job, you ask a Berkeley EECS student to help. They provide you with the following circuit and says it should make your comparator circuit more resistant to noise.



Determine v^+ as a function of v_s and V_{out} and other passive components.

- (d) Assume that V_{out} was at V_{SS} . What voltage would v_s have to be in order for V_{out} to change to V_{DD} ?
- (e) Now assume that V_{out} was V_{DD} . What voltage would v_s have to be in order for V_{out} to change to V_{SS} ?
- (f) From the previous parts, we see that we have different input threshold voltages depending on whether the comparator is outputting $V_{DD} = 5\text{ V}$ or $V_{SS} = -5\text{ V}$. Now pick values for R_1 and R_2 , which will remove the noise from the circuit. Choose values for R_1 and R_2 that set input threshold voltages of exactly $\pm 1\text{ V}$.

16. Circuit Design for COVID-19 (9 points)

After learning that the novel coronavirus pandemic has resulted in a global shortage of personal protective equipment, you decide to team up with other CS, EE, and ME Berkeley engineering students to build a special kind of respirator known as a PAPR, which is short for powered air purifying respirator. Your job is to quickly prototype the electrical parts of the design to demonstrate basic viability.

- (a) (3 points) Battery Status Indicator: You start by designing a circuit that will indicate whether the battery is sufficiently charged, or if the battery is low and needs to be recharged. To do this, you sketch out the following circuit that includes a comparator with 10 mV of built-in hysteresis, a couple of LEDs, some resistors, and a voltage source:

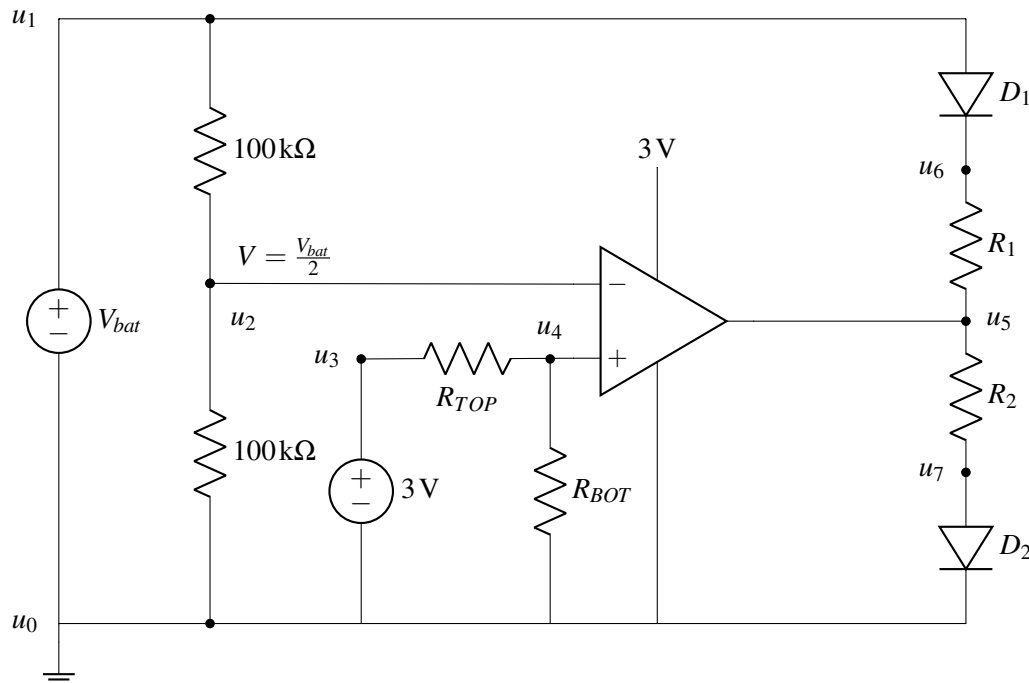

The green LED operates with a forward voltage, $V_{f,grn} = 2.5\text{V}$, and current $I_{f,grn} = 100\text{mA}$, so we need to determine the value of its current limiting resistor R_{GRN} . Similarly, the red LED operates with a forward voltage, $V_{f,red} = 2.5\text{V}$, and current $I_{f,red} = 50\text{mA}$, so we need to determine the value of its current limiting resistor R_{RED} .

Your team is using a Lithium-ion battery whose output, V_{bat} , ranges from 3.2 V when discharged to 4.2 V when charged. You have decided that 3.45 V is a reasonable threshold to switch between the green and red LEDs (representing 25% battery charge). You need to ensure that LED never draws more than I_f .

- i. (1 point) What is the correct mapping:
 - ii. (1 point) What should be the value of R_{GRN} ?
 - iii. (1 point) What should be the value of R_{TOP} ? (Assuming $R_{BOT} = 100\text{k}\Omega$)
- (b) (3 points) Debugging Indicator Instability: You breadboard your design in the lab and get it working! Upon further testing, your team members note that the red and green LEDs seem to rapidly flash back and forth when the battery level is close to 25% charge. You never noticed this on the bench when you simulated the battery draining by quickly sweeping the voltage from 4.2 V to 3.2 V, so you walk over to check out what is going (while maintaining a safe social distance).

You notice that your mechanical engineering friends have connected your circuit to the battery using a 10 ft length of 30 gauge wire ($\rho = 103 \text{ m}\Omega/\text{ft}$, $R = R_{\text{wire}_1}$) between the positive terminal of V_{bat} (node u_{1A}) and the rest of the circuit (node u_{1B}) but they are using a 6 inch jumper cable made of 22 gauge wire ($\rho = 16 \text{ m}\Omega/\text{ft}$, $R=R_{\text{wire}_2}$) to connect the negative terminal of the battery (node u_{0A}) and the rest of the circuit is ground (node u_{0B}).

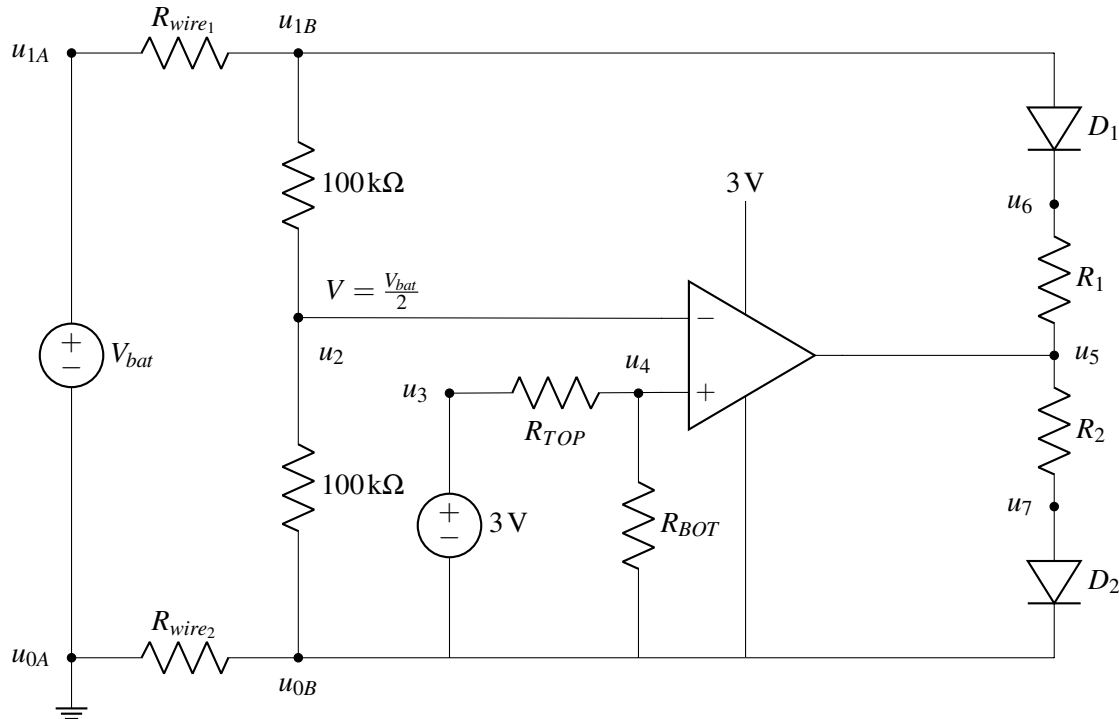

You suspect that there might be a sudden change in the voltage drop across these wires that reduces the voltage (nominally $\frac{V_{\text{bat}}}{2}$) at the V^- input of the comparator when toggling between the two LEDs. Ignoring any hysteresis provided by the comparator, you decide to add your own hysteresis to try to solve the flashing problem.

- i. (1 point) Between which two nodes in the circuit would you add a resistor, R_{HYST} , to add hysteresis to the comparator:
 - ii. (1 point) How much hysteresis (in volts) do you need to add to stop the rapid flashing between red and green LEDs around the 25% threshold?
 - iii. (1 point) Select the maximum value of R_{HYST} from this list, that will provide the required margin (ignoring any hysteresis provided by the comparator)?
- (c) Brainstorming Other Ideas: You describe the problem to some of your EECS 16A friends and they all offer their own ideas. You need to eliminate the bad ideas to preserve your time to test the good ones. Select ALL of the following ideas that WILL NOT solve the flashing problem:
- (A) Increase the value of R_{RED}
 - (B) Increase the value of R_{BOT} or decrease the value of R_{TOP}
 - (C) Swap the inputs to v^+ and v^- and the locations of D1 and D2
 - (D) Use green and red LEDs that draw the same current
 - (E) Use a green LED that draws much more current than the red LED
 - (F) Swap the inputs to v^+ and v^- and the polarities of D1 and D2

- (G) Use a larger diameter wire for the 10 ft run
- (H) Add a resistance in series with the jumper wire that is about the same as the 10 ft wire