

# EECS 16A Designing Information Devices and Systems I

Fall 2021

## Midterm 2

### 1. Passive Sign Convention (2 points)

Version 1:

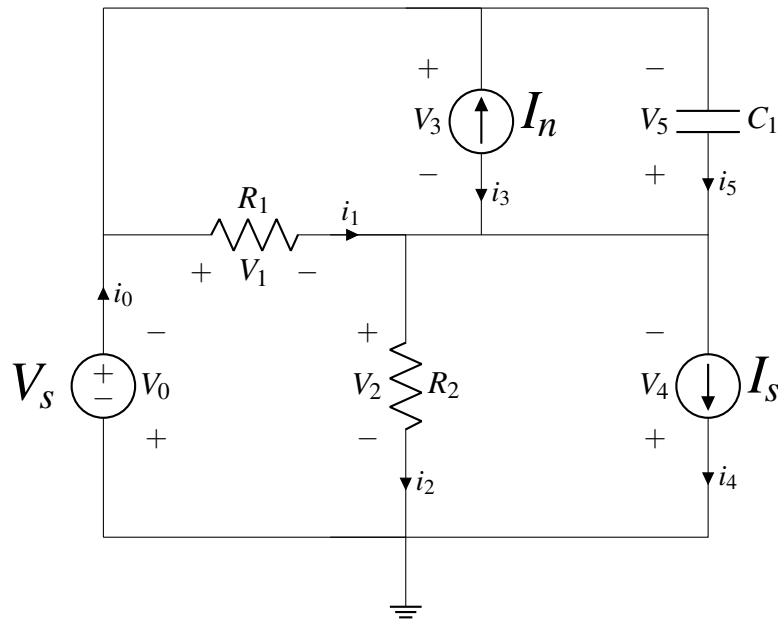

Which of the following components in the circuit have correct passive sign convention labels? Select True, if the element is labeled correctly and False if the element is labeled incorrectly.

$V_s$  : True/False?

$R_1$  : True/False?

$R_2$  : True/False?

$C_1$  : True/False?

$I_s$  : True/False?

$I_n$  : True/False?

#### Solution:

$V_s$ : True.  $V_s$  is correctly labeled because the direction of  $i_0$  is from the positive end of  $V_0$  to the negative end of  $V_0$ .

$R_1$ : True.  $R_1$  is correctly labeled because the direction of  $i_1$  is from the positive end of  $V_1$  to the negative end of  $V_1$ .

$R_2$ : True.  $R_2$  is correctly labeled because the direction of  $i_2$  is from the positive end of  $V_2$  to the negative end of  $V_2$ .

$C_1$ : False.  $C_1$  is incorrectly labeled because the direction of  $i_5$  is from the negative end of  $V_5$  to the positive end of  $V_5$  which contradicts with the passive sign convention.

$I_s$ : False.  $I_s$  is incorrectly labeled because the direction of  $i_4$  is from the negative end of  $V_4$  to the positive end of  $V_4$  which contradicts with the passive sign convention.

$I_n$ : True.  $I_n$  is correctly labeled because the direction of  $i_3$  is from the positive end of  $V_3$  to the negative end of  $V_3$ .

**Version 2** Which of the following components in the circuit have correct passive sign convention labels? Select True, if the element is labeled correctly and False if the element is labeled incorrectly.

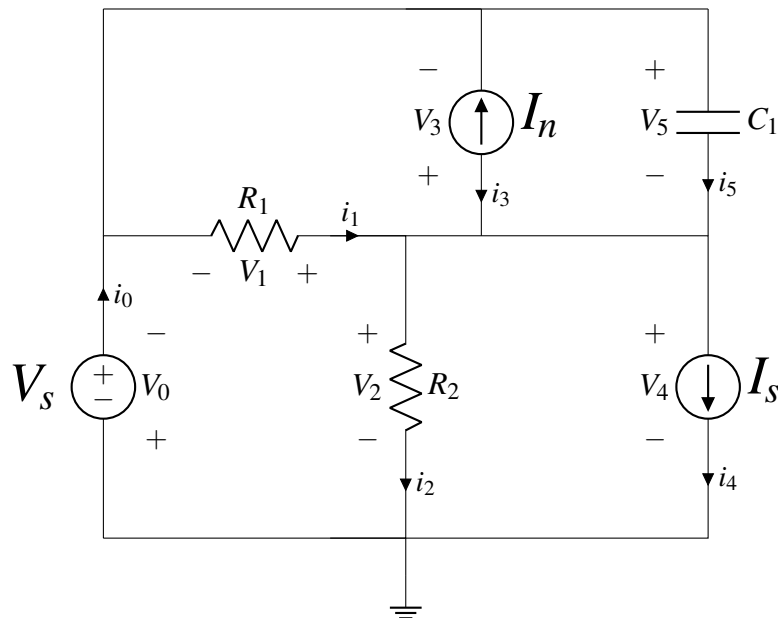

$V_s$  : True/False?

$R_1$  : True/False?

$R_2$  : True/False?

$C_1$  : True/False?

$I_s$  : True/False?

$I_n$  : True/False?

**Solution:**

$V_s$ : True.  $V_s$  is correctly labeled because the direction of  $i_0$  is from the positive end of  $V_0$  to the negative end of  $V_0$ .

$R_1$ : False.  $R_1$  is incorrectly labeled because the direction of  $i_1$  is from the negative end of  $V_1$  to the positive end of  $V_1$  which contradicts with the passive sign convention.

$R_2$ : True.  $R_2$  is correctly labeled because the direction of  $i_2$  is from the positive end of  $V_2$  to the negative end of  $V_2$ .

$C_1$ : True.  $C_1$  is correctly labeled because the direction of  $i_5$  is from the positive end of  $V_5$  to the negative end of  $V_5$ .

$I_s$ : True.  $I_s$  is correctly labeled because the direction of  $i_4$  is from the positive end of  $V_4$  to the negative end of  $V_4$ .

$I_n$ : False.  $I_n$  is incorrectly labeled because the direction of  $i_3$  is from the negative end of  $V_3$  to the positive end of  $V_3$  which contradicts with the passive sign convention.

## 2. Kirchoff's Laws (3 points)

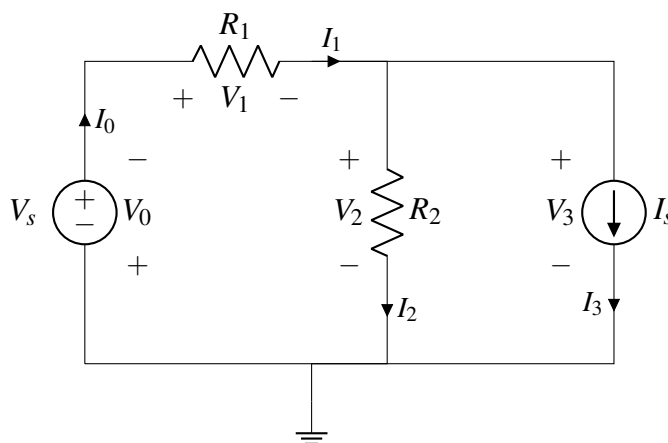

**Version 1:** Based on the circuit schematics above, which of the following equations are valid according to the Kirchoff's Laws? Select True if the equation is valid and False if the equation is not valid.

$V_0 = -V_2 - V_3$  : True/False?

$I_0 - I_1 = 0$  : True/False?

$V_0 + V_1 + V_3 = 0$  : True/False?

$V_0 + V_1 = V_2$  : True/False?

$I_2 = I_3$  : True/False?

$I_2 + I_3 = I_0$  : True/False?

### Solution:

$V_0 = -V_2 - V_3$  : False. This equation is not a valid KVL equation because  $V_2$  and  $V_3$  are not in the same loop with  $V_0$ .

$I_0 - I_1 = 0$  : True. This equation is a valid KCL equation because there is no other current entering/leaving the node between  $V_0$  and  $R_1$ .

$V_0 + V_1 + V_3 = 0$  : True. This equation is a valid KVL equation because  $V_0$ ,  $V_1$  and  $V_3$  are in the same loop.

$V_0 + V_1 = V_2$  : False. This equation is not a valid KVL equation because  $V_0$ ,  $V_1$  and  $V_2$  are in the same loop and their sum should be 0.

$I_2 = I_3$  : False. This equation is not a valid KCL equation because at the node between  $R_1$ ,  $R_2$  and  $I_s$  has one entering current  $I_1$  and two exiting currents  $I_2$  and  $I_3$ , the correct KCL equation should be  $I_1 = I_2 + I_3$ .

$I_2 + I_3 = I_0$  : True. This equation is a valid KCL equation because  $I_0 = I_1$  and  $I_1 = I_2 + I_3$  from the explanation above.

**Version 2:** Based on the above circuit schematics, which of the following equations are valid according to the Kirchoff's Laws? Select True if the equation is valid and False if the equation is not.

$V_0 = -V_1 - V_2$  : True/False?

$I_0 + I_1 = 0$  : True/False?

$V_0 + V_2 + V_3 = 0$  : True/False?

$V_0 + V_1 = V_3$  : True/False?

$I_2 = I_3$  : True/False?

$I_2 + I_3 = I_1$  : True/False?

**Solution:**

$V_0 = -V_1 - V_2$  : True. This equation is a valid KVL equation because  $V_0$ ,  $V_1$  and  $V_2$  are in the same loop and their sum is 0.

$I_0 + I_1 = 0$  : False. This equation is not a valid KCL equation because there is no other current entering/leaving the node between  $V_0$  and  $R_1$  therefore  $I_0 = I_1$ .

$V_0 + V_2 + V_3 = 0$  : False. This equation is not a valid KVL equation because  $V_2$  and  $V_3$  are not in the same loop with  $V_0$ .

$V_0 + V_1 = V_3$  : False. This is not a valid KVL equation because  $V_0$ ,  $V_1$  and  $V_3$  are in the same loop and should have a sum of 0 based on their labeled directions.

$I_2 = I_3$  : False. See explanation in version 1 part 5.

$I_2 + I_3 = I_1$  : True. See explanation in version 1 part 5.

**3. Resistive 2D Touchscreen (1) (3 points)**

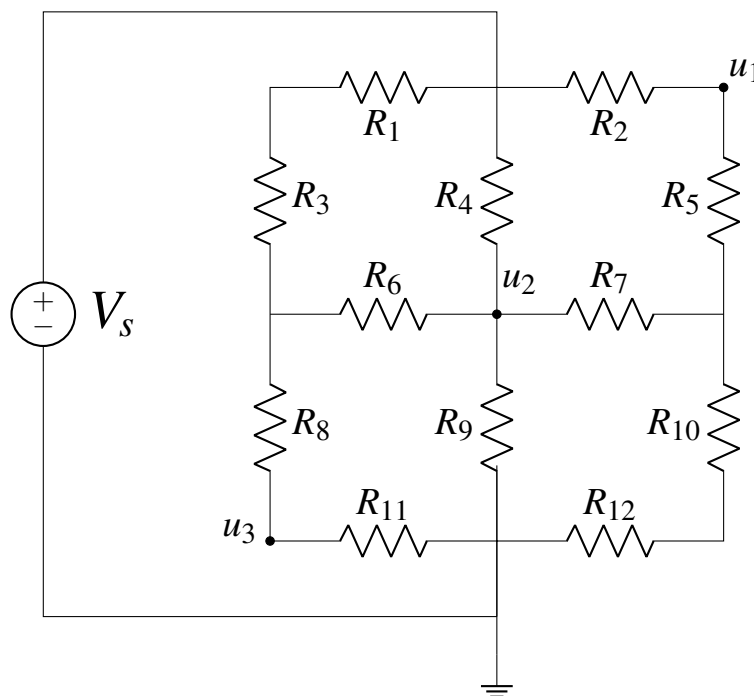

**Version 1:** Given the above circuit, find node voltages at the given nodes  $u_1$ ,  $u_2$ , and  $u_3$  where all resistors have resistance  $R = 500\Omega$  and  $V_s = 5V$ .

**Version 2:** Given the above circuit, find node voltages at the given nodes  $u_1$ ,  $u_2$ , and  $u_3$  where all resistors have resistance  $R = 500\Omega$  and  $V_s = 10V$ .

**Version 3:** Given the above circuit, find node voltages at the given nodes  $u_1$ ,  $u_2$ , and  $u_3$  where all resistors have resistance  $R = 400\Omega$  and  $V_s = 16V$ .

**Solution:** To find node voltages in this circuit, use voltage dividers. We can start by making the assumption that  $R_6$  and  $R_7$  do not affect circuit operation; thus  $u_2$ , the node adjacent to  $R_3$ ,  $R_6$ , and  $R_8$ , and the node adjacent to  $R_5$ ,  $R_7$ , and  $R_{10}$  have the same voltage. We can then use voltage dividers to solve for the node voltages in each vertical segment of the circuit, and then verify our assumption.

Solving first for the middle segment, the resistors to look at are  $R_4$  and  $R_9$ , with node  $u_2$  between them. The voltage at  $u_2$  is given by:

$$u_2 = \frac{R_9}{R_4 + R_9} V_s = \frac{1}{2} V_s$$

**Version 1:**  $u_2 = 2.5V$

**Version 2:**  $u_2 = 5V$

**Version 3:**  $u_2 = 8V$

On the left segment, the current flows through resistors  $R_1$ ,  $R_3$ ,  $R_8$ , and  $R_{11}$ . Note that these resistors are in series, so  $R_1$ ,  $R_3$ , and  $R_8$  together have an equivalent resistance of  $R_1 + R_3 + R_8$ . Solving for  $u_3$  is given by a voltage divider formula:

$$u_3 = \frac{R_{11}}{R_1 + R_3 + R_8 + R_{11}} V_s = \frac{1}{4} V_s$$

**Version 1:**  $u_3 = 1.25V$

**Version 2:**  $u_3 = 2.5V$

**Version 3:**  $u_3 = 4V$

On the right segment, the current flows through resistors  $R_2$ ,  $R_5$ ,  $R_{10}$ , and  $R_{12}$ . Note that these resistors are in series, so  $R_5$ ,  $R_{10}$ , and  $R_{12}$  together have an equivalent resistance of  $R_5 + R_{10} + R_{12}$ . Solving for  $u_1$  is given by a voltage divider formula:

$$u_1 = \frac{R_5 + R_{10} + R_{12}}{R_2 + R_5 + R_{10} + R_{12}} V_s = \frac{3}{4} V_s$$

**Version 1:**  $u_1 = 3.75V$

**Version 2:**  $u_1 = 7.5V$

**Version 3:**  $u_1 = 12V$

To verify the assumption we made at the beginning, we can first use voltage dividers on the left segment to calculate the voltage at the node adjacent to  $R_3$ ,  $R_6$ , and  $R_8$ :  $u = \frac{R_8 + R_{11}}{R_1 + R_3 + R_8 + R_{11}} V_s = \frac{1}{2} V_s$

Next we can use a voltage divider on the right segment to calculate the voltage at the node adjacent to  $R_5$ ,  $R_7$ , and  $R_{10}$ :  $u = \frac{R_{10} + R_{12}}{R_2 + R_5 + R_{10} + R_{12}} V_s = \frac{1}{2} V_s$

We have already calculated  $u_2 = \frac{1}{2} V_s$ , so we can see that our assumption that those three nodes have the same voltage is valid, and there is no voltage drop nor current through resistors  $R_6$  and  $R_7$ .

#### 4. Resistive 2D Touchscreen (2) (4 points)

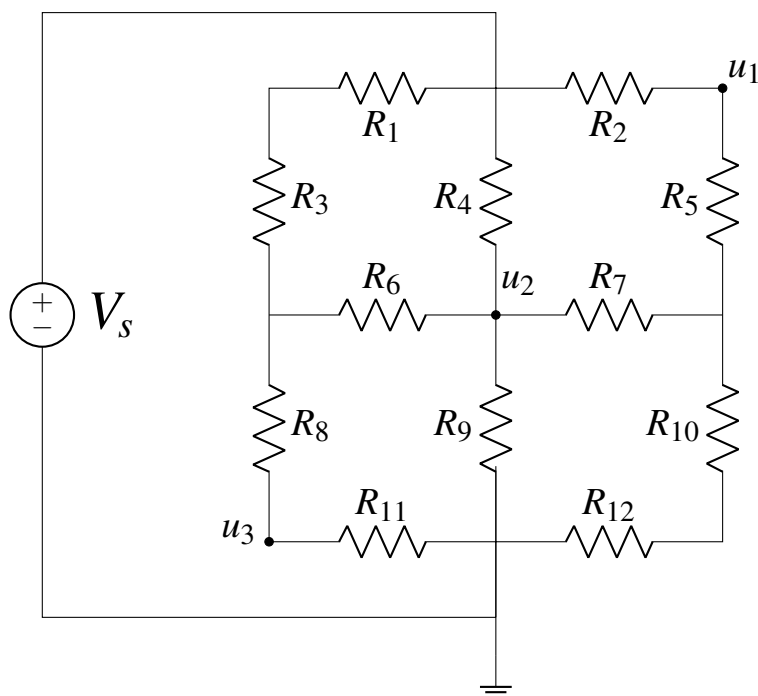

Using the above circuit schematics, indicate which node voltages, if any, will change if the value of the given resistor is changed.

**Version 1:** By default, every resistor has the same resistance  $R = 500\Omega$ .  $V_s = 5V$ .

**Version 2:** By default, every resistor has the same resistance  $R = 600\Omega$ .  $V_s = 4V$ .

**Version 3:** By default, every resistor has the same resistance  $R = 700\Omega$ .  $V_s = 8V$ .

For each response, select a combination of the following values:  $u_1$ ,  $u_2$ ,  $u_3$ , None. For example, if  $u_1$  and  $u_2$  change, select " $u_1, u_2$ ". And if the node voltages are unchanged then you can select None.

(a) **Version 1:**  $R_6$  is changed to  $R = 1000\Omega$ , all others stay at  $R = 500\Omega$ .

**Version 2:**  $R_6$  is changed to  $R = 1200\Omega$ , all others stay at  $R = 600\Omega$ .

**Version 3:**  $R_6$  is changed to  $R = 1400\Omega$ , all others stay at  $R = 700\Omega$ .

**Solution:** None. Note that the same solution applies to all versions of the question. When all the resistors except  $R_6$  remain the same, the voltages at  $u_2$ , the node adjacent to  $R_3$ ,  $R_6$ , and  $R_8$ , and the node adjacent to  $R_5$ ,  $R_7$ , and  $R_{10}$  are the same. Thus there is no voltage drop through  $R_6$ . Changing the value of  $R_6$  does not change any of the node voltages.

(b) **Version 1:**  $R_2$  is changed to  $R = 1000\Omega$ ,  $R_5 = 0\Omega$ , all others stay at  $R = 500\Omega$ .

**Version 2:**  $R_2$  is changed to  $R = 1200\Omega$ ,  $R_5 = 0\Omega$ , all others stay at  $R = 600\Omega$ .

**Version 3:**  $R_2$  is changed to  $R = 1400\Omega$ ,  $R_5 = 0\Omega$ , all others stay at  $R = 700\Omega$ .

**Solution:**  $u_1$ . Note that the same solution applies to all versions of the question. When  $R_2$  is doubled and  $R_5$  is set to  $0\Omega$ , the voltage drop across  $R_2$  changes, thus changing  $u_1$  to  $\frac{1}{2}V_s$ , calculated using a voltage divider equation:

$$u_1 = \frac{R_5 + R_{10} + R_{12}}{R_2 + R_5 + R_{10} + R_{12}} V_s = \frac{1}{2} V_s$$

However, this change does not impact the rest of the circuit as the total resistance across the resistors  $R_2$  and  $R_5$  in series does not change. Thus  $R_6$  and  $R_7$  still have no current across them, allowing the

other parts of the circuit to remain the same. The voltage at node  $u_2$  is, as before, given by  $\frac{1}{2}V_s$ . The voltage at node  $u_3$  is, as before, given by  $\frac{1}{4}V_s$ .

(c) **Version 1:**  $R_1$  is changed to  $R = 1000\Omega$ ,  $R_2 = 1000\Omega$ ,  $R_3 = R_5 = 0\Omega$ , and all others stay at  $R = 500\Omega$ .

**Version 2:**  $R_1$  is changed to  $R = 1200\Omega$ ,  $R_2 = 1200\Omega$ ,  $R_3 = R_5 = 0\Omega$ , and all others stay at  $R = 600\Omega$ .

**Version 3:**  $R_1$  is changed to  $R = 1400\Omega$ ,  $R_2 = 1400\Omega$ ,  $R_3 = R_5 = 0\Omega$ , and all others stay at  $R = 700\Omega$ .

**Solution:**  $u_1$ . Note that the same solution applies to all versions of the question. Similar to part b, when  $R_1$  is doubled and  $R_3$  is set to  $0\Omega$ , the voltage at the node adjacent to  $R_3$ ,  $R_6$ , and  $R_8$  can be given by

$$u = \frac{R_8 + R_{11}}{R_1 + R_3 + R_8 + R_{11}} V_s = \frac{1}{2} V_s$$

Similarly, doubling  $R_2$  and setting  $R_5$  to  $0\Omega$  changes  $u_1$  but does not change the voltage at the node adjacent to  $R_5$ ,  $R_7$ , and  $R_{10}$ . Thus there is no current through  $R_6$  and  $R_7$  and the voltage at node  $u_2$  is, as before, given by  $\frac{1}{2}V_s$ . The voltage at node  $u_3$  is, as before, given by  $\frac{1}{4}V_s$ . Thus this change affects node  $u_1$  but  $u_2$  and  $u_3$  have the same voltage values as before.

(d) **Version 1:**  $R_4$  is changed to  $R = 1000\Omega$ , and all others stay at  $R = 500\Omega$ .

**Version 2:**  $R_4$  is changed to  $R = 1200\Omega$ , and all others stay at  $R = 600\Omega$ .

**Version 3:**  $R_4$  is changed to  $R = 1400\Omega$ , and all others stay at  $R = 700\Omega$ .

**Solution:**  $u_1, u_2, u_3$ . Note that the same solution applies to all versions of the question. When the value of  $R_4$  is changed, there is current flowing through  $R_6$  and  $R_7$ . Thus using voltage dividers does not hold through the three vertical segments of the circuit. Because of this, the ratios we had previously used to calculate the values of  $u_1, u_2$ , and  $u_3$  do not hold, thus all the node voltage values are different.

## 5. Resistor Equivalence (1) (2 points)

Choose the equivalent circuit to circuit 1, options A-E show potential simplified equivalent circuits.

Circuit 1 is equivalent to \_\_\_

Circuit 1:

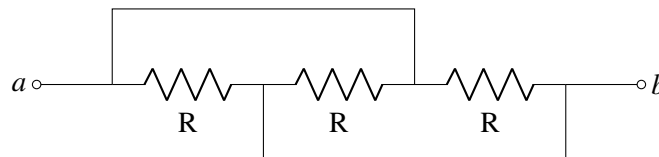

**Version 1:**

A:

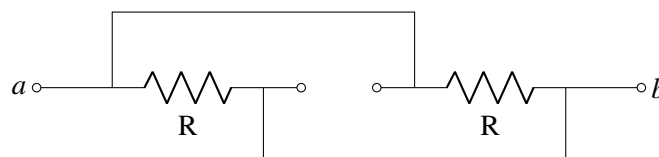

B:

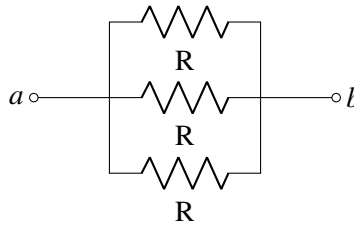

C:

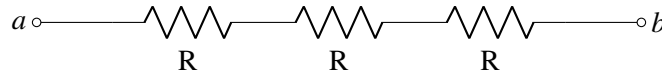

D:

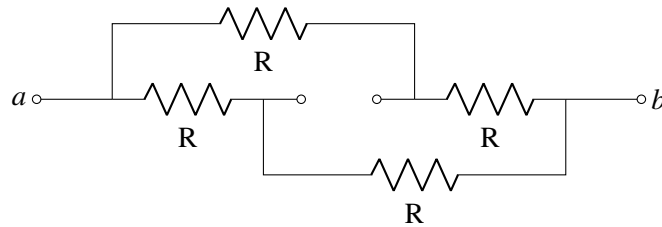

E:

None of the above

**Solution:**

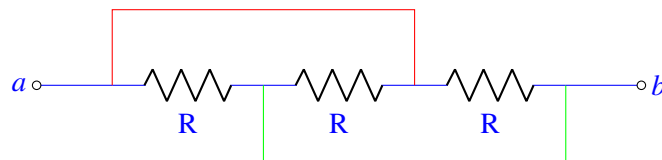

In the above circuit, we can see that there are only two nodes (red and green). We can see that the red node is in fact  $a$  and the green node is in fact  $b$ . We can observe in the above circuit that one end of each resistor is connected to the red node and the other end of each resistor is connected to the green node.

Hence, the equivalent circuit is:

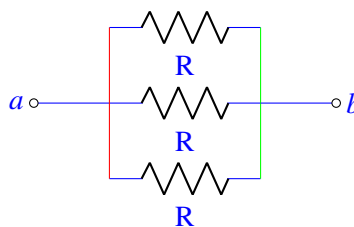



Hence, the correct answer is:

**Version 1:** option (B).

**Version 2:** option (C).

**Version 3:** option (A).

### 6. Resistor Equivalence (2) (2 points)

**Version 1:** The value of R for this question is  $15k\Omega$ .

**Version 2:** The value of R for this question is  $10k\Omega$ .

**Version 3:** The value of R for this question is  $25k\Omega$ .

The equivalent resistance of this circuit between nodes a and b is \_\_\_  $k\Omega$ .

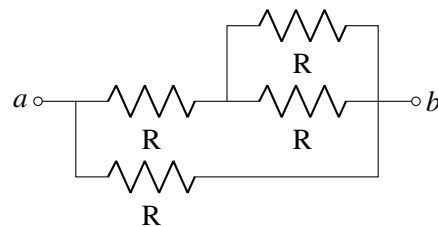

**Solution:** We need to solve for the equivalent resistance between the terminals a and b for the following circuit (given that  $R = 10k\Omega$ ):

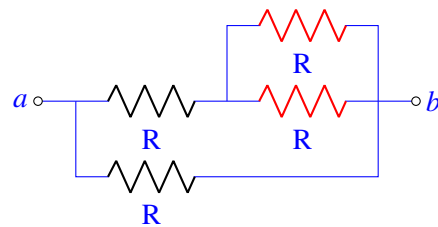

In the above circuit, we can see that the two red resistors are in parallel, hence they can be combined into one resistor with equivalent resistance:

$$R_{eq} = (R||R) = \frac{R}{2}$$

The new equivalent circuit is:

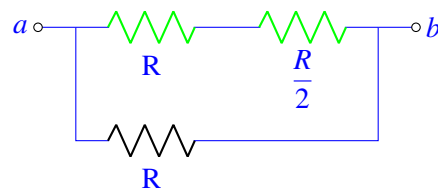

In the above circuit, we can see that the two green resistors are in series, hence they can be combined into one resistor with equivalent resistance:

$$R_{eq} = \left(R + \frac{R}{2}\right) = \frac{3R}{2}$$

The new equivalent circuit is:

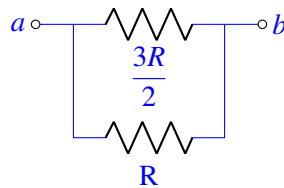

In the above circuit, we can see that the two resistors are in parallel, hence they can be combined into one resistor with equivalent resistance  $R_{eq}$ , which is the equivalent resistance between a and b:

$$R_{eq} = R_{ab} = \left(R \parallel \frac{3R}{2}\right) = \frac{3R}{5}$$

**Version 1:**

$$R_{eq} = \frac{3R}{5} = \frac{3}{5} 15k\Omega = 9k\Omega$$

**Version 2:**

$$R_{eq} = \frac{3R}{5} = \frac{3}{5} 10k\Omega = 6k\Omega$$

**Version 3:**

$$R_{eq} = \frac{3R}{5} = \frac{3}{5} 25k\Omega = 15k\Omega$$

## 7. Capacitance Equivalence (2 points)

Calculate the equivalent capacitance of the following circuit between nodes a and b given the corresponding capacitance.

**Version 1:** Assuming that the capacitance values are  $C_0=35\mu\text{F}$  and  $C_1=C_2=10\mu\text{F}$ .

**Version 2:** Assuming that the capacitance values are  $C_0=15\mu\text{F}$  and  $C_1=C_2=20\mu\text{F}$ .

**Version 3:** Assuming that the capacitance values are  $C_0=10\mu\text{F}$  and  $C_1=C_2=20\mu\text{F}$ .

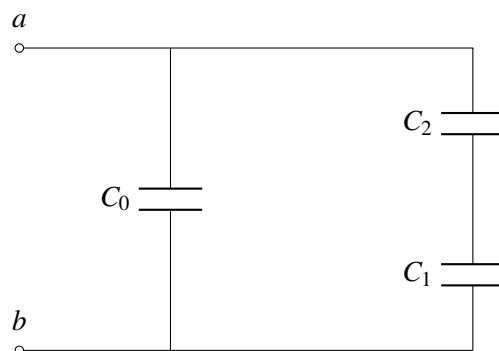

**Solution:** To get the equivalent capacitance  $C_{ab}$ , we can first combine  $C_1$  and  $C_2$ . They are in series, so we use the parallel operator:

$$C_{12} = \frac{C_1 C_2}{C_1 + C_2}$$

**Version 1:**  $C_{12} = 5\mu\text{F}$

**Version 2:**  $C_{12} = 10\mu\text{F}$

**Version 3:**  $C_{12} = 10\mu\text{F}$

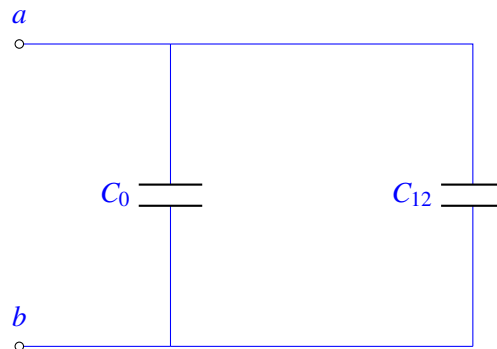

We will get  $C_{ab}$  by combining  $C_{12}$  and  $C_0$ . They are in parallel, so we sum their capacitance together:

**Version 1:**  $C_{ab} = C_{12} + C_0 = 40\mu\text{F}$

**Version 2:**  $C_{ab} = C_{12} + C_0 = 25\mu\text{F}$

**Version 3:**  $C_{ab} = C_{12} + C_0 = 20\mu\text{F}$

The following diagram is related to the next two questions. A micro-electromechanical systems (MEMS) accelerometer can be modeled as two plates—a fixed plate and a moving plate—connected by a spring, shown below. As acceleration changes, the force exerted on the moving plate changes, and the distance between the plates also changes. We can detect this physical change in distance by measuring the capacitance between the two plates. You can assume that  $\epsilon = \epsilon_0$  where  $\epsilon_0$  is the permittivity of free space.

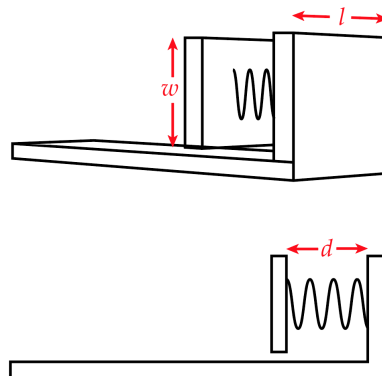

## 8. Accelerometer - Physical Capacitors (2 points)

At 0g acceleration, the two plates have distance  $d = d_0$  between them. What is the capacitance between the two accelerometer plates?

**Solution:**

$$C_0 = \epsilon_0 \frac{wl}{d_0}$$

### 9. Accelerometer - Physical Capacitors (2 points)

**Version 1:** At 1g acceleration, the two plates have distance  $d = 2d_0$  between them. How does the capacitance change from the 0g case?

**Version 2:** At 1g acceleration, the two plates have distance  $d = 4d_0$  between them. How does the capacitance change from the 0g case?

**Version 3:** At 1g acceleration, the two plates have distance  $d = 0.5d_0$  between them. How does the capacitance change from the 0g case?

**Solution:**

**Version 1:** Capacitance is halved.

$$C_1 = \epsilon_0 \frac{wl}{2d_0} = \frac{1}{2}C_0$$

**Version 2:** Capacitance is divided by four.

$$C_1 = \epsilon_0 \frac{wl}{4d_0} = \frac{1}{4}C_0$$

**Version 3:** Capacitance is doubled.

$$C_1 = \epsilon_0 \frac{wl}{0.5d_0} = 2C_0$$

### 10. Physical Resistors (3 points)

**Version 1:** Using the rectangular prism ( $h = 1\text{mm}$ ,  $w = 4\text{mm}$ ,  $l = 10\text{mm}$ ) made using carbon film ( $\rho = 50 \times 10^{-4}\Omega\text{m}$ ) as a resistor, measuring the resistance across which two opposing faces of the prism will result in  $R = 2\Omega$ ? Note that  $\text{mm} = 10^{-3}\text{m}$ .

**Version 2:** Using the rectangular prism ( $h = 1\text{mm}$ ,  $w = 4\text{mm}$ ,  $l = 10\text{mm}$ ) made using carbon film ( $\rho = 50 \times 10^{-4}\Omega\text{m}$ ) as a resistor, measuring the resistance across which two opposing faces of the prism will result in  $R = 12.5\Omega$ ? Note that  $\text{mm} = 10^{-3}\text{m}$ .

**Version 3:** Using the rectangular prism ( $h = 1\text{mm}$ ,  $w = 4\text{mm}$ ,  $l = 10\text{mm}$ ) made using carbon film ( $\rho = 50 \times 10^{-4}\Omega\text{m}$ ) as a resistor, measuring the resistance across which two opposing faces of the prism will result in  $R = 0.125\Omega$ ? Note that  $\text{mm} = 10^{-3}\text{m}$ .

**Version 4:** Using the rectangular prism ( $h = 1\text{mm}$ ,  $w = 4\text{mm}$ ,  $l = 10\text{mm}$ ) made using carbon film ( $\rho = 50 \times 10^{-4}\Omega\text{m}$ ) as a resistor, measuring the resistance across which two opposing faces of the prism will result in  $R = 5\Omega$ ? Note that  $\text{mm} = 10^{-3}\text{m}$ .

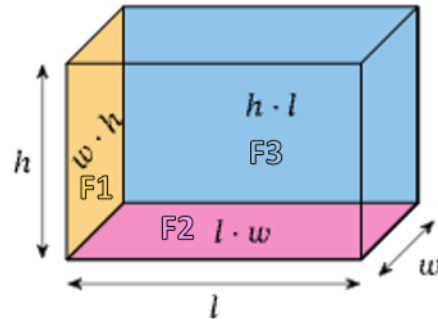
**Solution:**

**Version 1:** The key to this question is not just knowing the equation  $R = \rho \frac{l}{A}$ , but also which dimensions to use on the numerator and denominator of the equation. Here, the only configuration of  $h, w, l$  that yields  $R = 2\Omega$  is given by:

$$R = \rho \frac{w}{hl} = 50 \times 10^{-4} \Omega \text{m} \frac{4 \times 10^{-3} \text{m}}{(1 \times 10^{-3} \text{m})(10 \times 10^{-3} \text{m})} = 2\Omega$$

Therefore, we should measure from the  $F3$  face to the opposite face of the resistor.

**Version 2:** Here, the only configuration of  $h, w, l$  that yields  $R = 12.5\Omega$  is given by:

$$R = \rho \frac{l}{hw} = 50 \times 10^{-4} \Omega \text{m} \frac{10 \times 10^{-3} \text{m}}{(1 \times 10^{-3} \text{m})(4 \times 10^{-3} \text{m})} = 12.5\Omega$$

Therefore, we should measure from the  $F1$  face to the opposite face of the resistor.

**Version 3:** Here, the only configuration of  $h, w, l$  that yields  $R = 0.125\Omega$  is given by:

$$R = \rho \frac{h}{lw} = 50 \times 10^{-4} \Omega \text{m} \frac{1 \times 10^{-3} \text{m}}{(10 \times 10^{-3} \text{m})(4 \times 10^{-3} \text{m})} = 0.125\Omega$$

Therefore, we should measure from the  $F2$  face to the opposite face of the resistor.

**Version 4:** Here, there is no configuration of  $h, w, l$  that yields  $R = 5\Omega$ . In order to achieve this value, we would have to either change the material of the resistor or its dimensions.

**11. Charge Sharing 1 (2 points)**

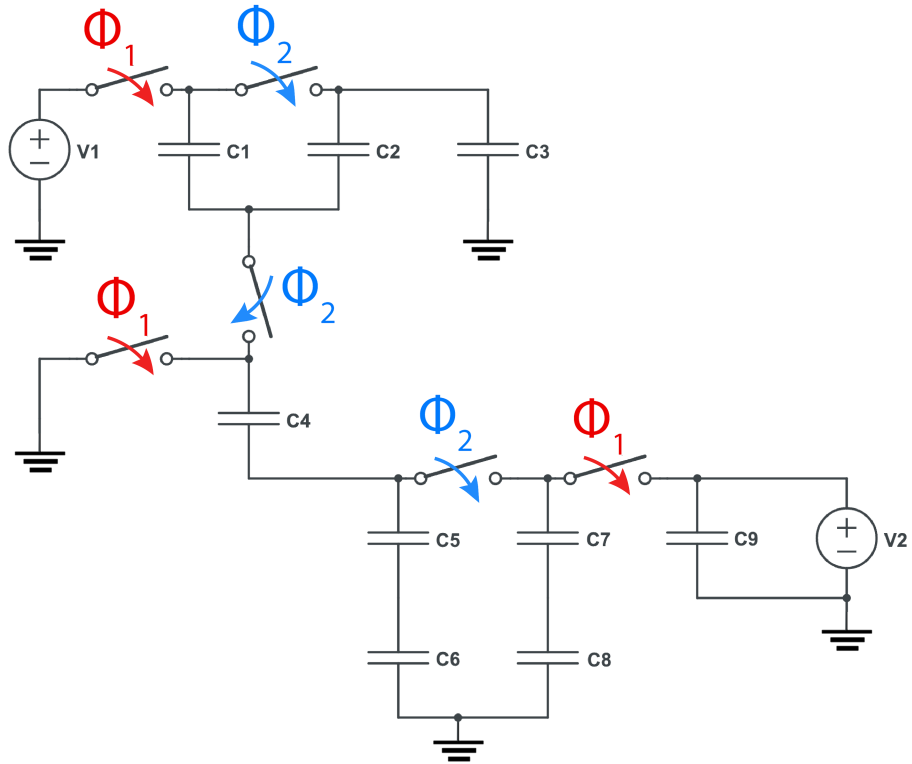

What will the above circuit look like after the phase 1 switches (labeled  $\phi_1$ ) are closed? Note that phase 2 switches (labeled  $\phi_2$ ) remain open.

A.

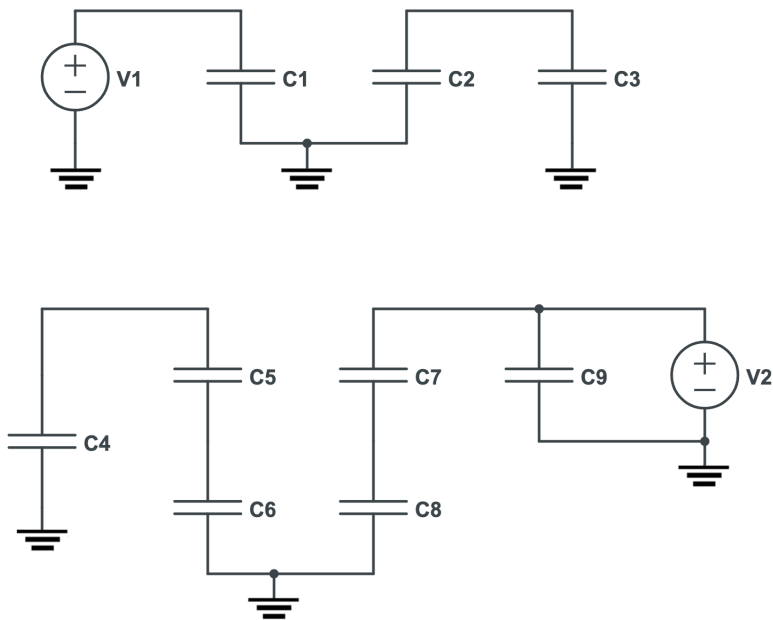

B.

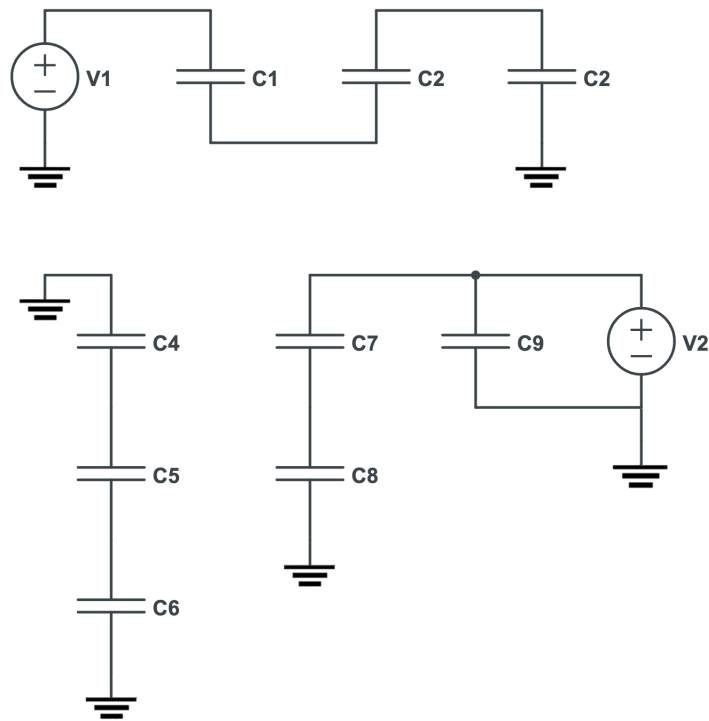

C.

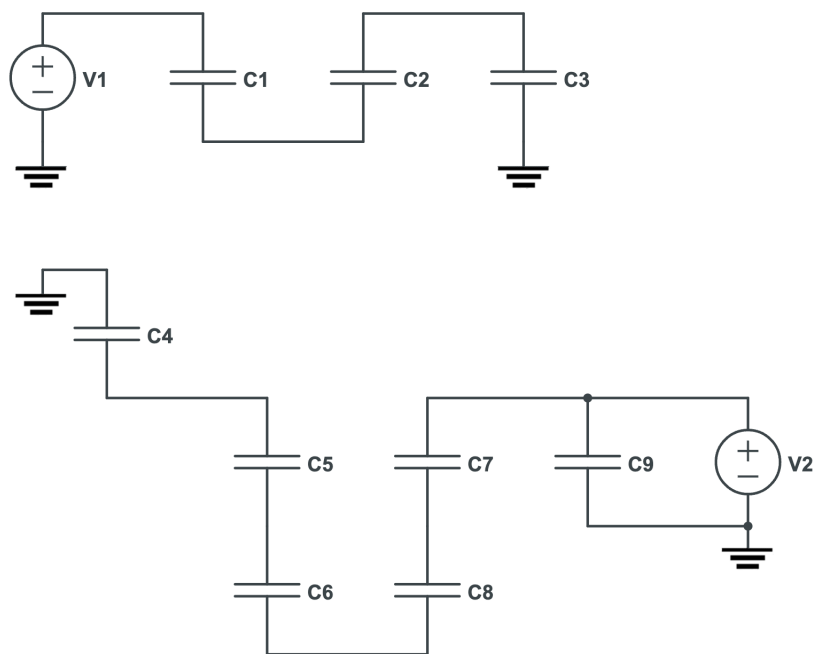

**Solution:** After phase 1, the circuit will look like the following:

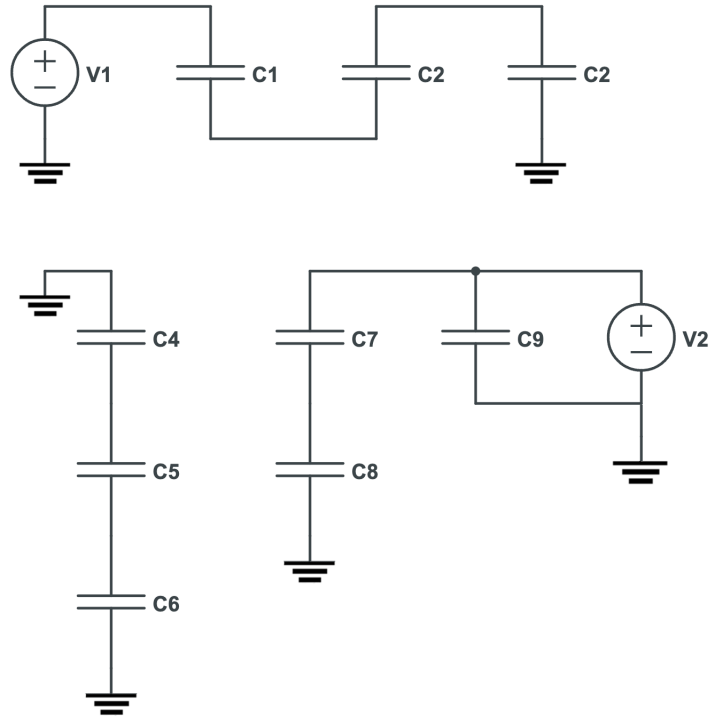

Correct answers:

**Version 1:** option (A)

**Version 2:** option (C)

**Version 3:** option (B)

Some important notes to keep in mind when opening and closing switches:

- (a) Ground is shared throughout the circuit. Thus, you can split up parts of the circuit that are connected to the same ground. This has been done with  $C_5, C_6$  and  $C_7, C_8$ .
- (b) Do not introduce in new grounds to nodes. Even though the phase 2 switch connecting  $C_1 || C_2$  to  $C_4$  is not closed, it is not replaced with a ground.

**12. Charge Sharing 2 (3 points)**

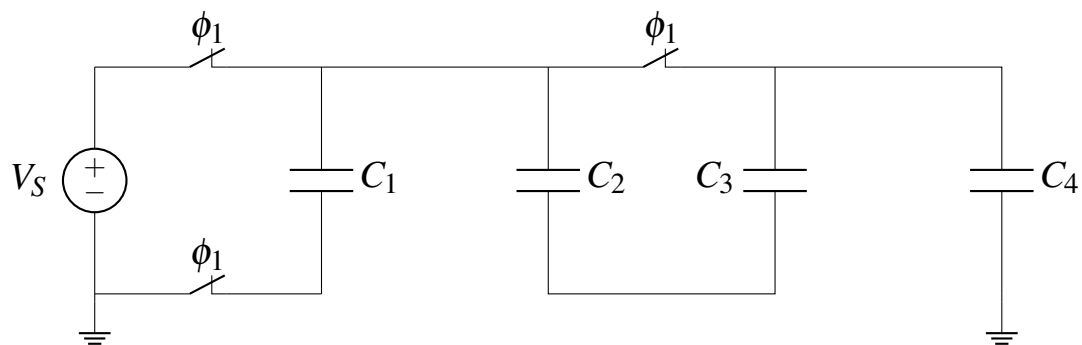



**Version 1:** Assume  $V_s = 3V$  and  $C_1 = C_2 = C_3 = C_4 = 5F$ .

**Version 2:** Assume  $V_s = 2V$  and  $C_1 = C_2 = C_3 = C_4 = 3F$ .

**Version 3:** Assume  $V_s = 1V$  and  $C_1 = 1F, C_2 = 2F, C_3 = 3F, C_4 = 4F$ . All capacitors are initially uncharged before the switches are closed. The switches are closed and the circuit reaches steady state.

- (a) How much charge is on  $C_4$  after the switches are closed?

**Solution:**

After the phase 1 switches close,  $C_1, C_2, C_3$ , and  $C_4$  are all attached to the top node, which is at a voltage of  $V_s$ .  $C_1$  and  $C_4$  are attached to ground on the other side, and  $C_2$  and  $C_3$  are attached to the node labeled  $U_x$ . Note that  $U_x$  is a floating node, thus we can use charge conservation.

The charge on  $C_4$  after closing the switch is the capacitance times the voltage across it:

$$Q_4 = C_4 * (V_s - 0)$$

For **version 1**,  $Q_4 = 15V$ .

For **version 2**,  $Q_4 = 6V$

For **version 3**,  $Q_4 = 4V$

- (b) How much charge is on  $C_2$  after the switches are closed?

**Solution:**

**Solution 1:** We can see that capacitors  $C_2$  and  $C_3$  are shorted out when the switch close. This makes the total voltage drop across the series combination equals to zero. And if the total voltage across both capacitors is zero then the voltage drop across both  $C_2$  and  $C_3$  is zero. This means that  $Q_2 = 0$  for **all versions**.

**Solution 2:** The charge on  $C_2$  after closing the switch is the capacitance times the voltage across it, and we can use charge conservation to solve for the unknown potential at  $U_x$  where  $U_x$  is the node connecting  $C_2$  and  $C_3$ :

$Q_2 = C_2 * (V_s - U_x)$  Total charge on  $U_x$  after closing switches:  $Q_{total,1} = -C_2(V_s - U_x) - C_3(V_s - U_x)$  Total charge on  $U_x$  before closing switches (remember that capacitors are initially uncharged):  $Q_{total,0} = 0$  Thus:  $-C_2(V_s - U_x) = C_3(V_s - U_x)$  The previous equation is only valid iff  $V_s = U_x$  and for all other  $U_x$  values the equation will reduce to  $-C_2 = C_3$  which would not be valid. This means that the voltage drop across  $C_2$  is 0V. Hence the charge stored in  $C_2$  is zero. And this is true for **all versions**.  
 $Q_2 = C_2(V_s - U_x) = C_2(V_s - V_s) = 0$

### 13. Charge Sharing 3 (6 points)

**Version 1:** In the following circuit, you are given that capacitors  $C_A, C_B$ , and  $C_C$  have charges  $Q_A, Q_B$ , and  $Q_C$  and stored in them, respectively, where the polarity of the charges are depicted in the schematics below. You are also told that  $C_A = C_B = C_C = 1F$  and the total charge at node  $x$  is  $Q_x = 4$  Coulombs and the total charge at node  $y$  is  $Q_y = 1$  Coulomb. What are the voltages at node  $y(V_y)$  and node  $x(V_x)$ ?

**Version 2:** In the following circuit, you are given that capacitors  $C_A, C_B$ , and  $C_C$  have charges  $Q_A, Q_B$ , and  $Q_C$  and stored in them, respectively, where the polarity of the charges are depicted in the schematics below. You are also told that  $C_A = C_B = C_C = 1F$  and the total charge at node  $x$  is  $Q_x = 5$  Coulombs and the total charge at node  $y$  is  $Q_y = 2$  Coulomb. What are the voltages at node  $y(V_y)$  and node  $x(V_x)$ ?

**Version 3:** In the following circuit, you are given that capacitors  $C_A, C_B$ , and  $C_C$  have charges  $Q_A, Q_B$ , and  $Q_C$  and stored in them, respectively, where the polarity of the charges are depicted in the schematics

below. You are also told that  $C_A = C_B = C_C = 1F$  and the total charge at node  $x$  is  $Q_x = 7$  Coulombs and the total charge at node  $y$  is  $Q_y = 4$  Coulomb. What are the voltages at node  $y$  ( $V_y$ ) and node  $x$  ( $V_x$ )?

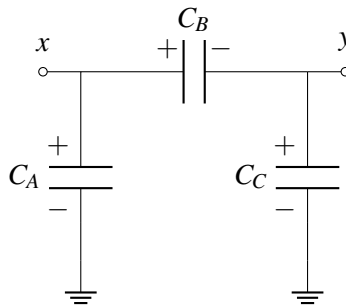

### Solution:

In the above circuit,  $C_A$  and  $C_B$  contribute to the charge on node  $x$ . Recall that the charge on a capacitor is equal to the capacitance times the voltage across the capacitor:

$$Q_X = Q_A + Q_B$$

$$Q_X = C_A(V_x - 0) + C_B(V_x - V_y)$$

Similarly,  $C_B$  and  $C_C$  contribute to the charge on node  $y$ . Pay attention to the polarity of the capacitors. Now, the negative plate of  $C_B$  is connected to  $y$ , thus  $Q_B$  is negative:

$$Q_Y = -Q_B + Q_C$$

$$Q_Y = -C_B(V_x - V_y) + C_C(V_y)$$

Now we have two equations with two unknowns, and we can solve. Solving is easiest when you plug in known values first.

$$C_A = C_B = C_C = 1F$$

$$Q_X = C_A(V_x - 0) + C_B(V_x - V_y) \Rightarrow Q_X = V_x + V_x - V_y = 2V_x - V_y$$

$$Q_Y = -C_B(V_x - V_y) + C_C(V_y) \Rightarrow Q_Y = -V_x + V_y + V_y = -V_x + 2V_y$$

Using substitution, we get:

#### Version 1:

$$V_x = 3V$$

$$V_y = 2V$$

#### Version 2:

$$V_x = 4V$$

$$V_y = 3V$$

#### Version 3:

$$V_x = 6V$$

$$V_y = 5V$$

**14. Op Amps (5 points)**

**Version 1:** Oscar has built the following circuit. What is the output  $V_{out}$  from his circuit when  $V_s = 5V$ ,  $R_1 = R_2 = R_3 = 1\Omega$ , and  $V_{in} = 6V$ ?

**Version 2:** Oscar has built the following circuit. What is the output  $V_{out}$  from his circuit when  $V_s = 5V$ ,  $R_1 = R_2 = R_3 = 4\Omega$ , and  $V_{in} = 5V$ ?

**Version 3:** Oscar has built the following circuit. What is the output  $V_{out}$  from his circuit when  $V_s = 6V$ ,  $R_1 = R_2 = R_3 = 2\Omega$ , and  $V_{in} = 7V$ ?

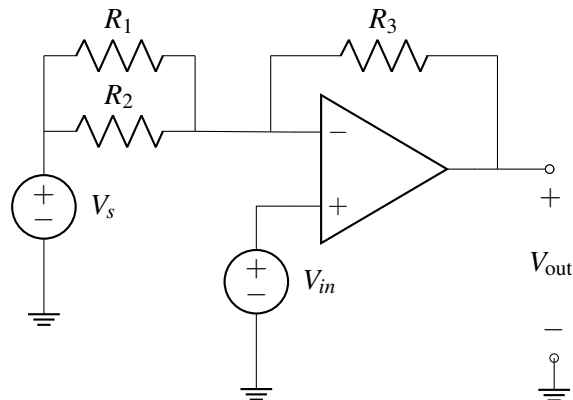

**Solution:**

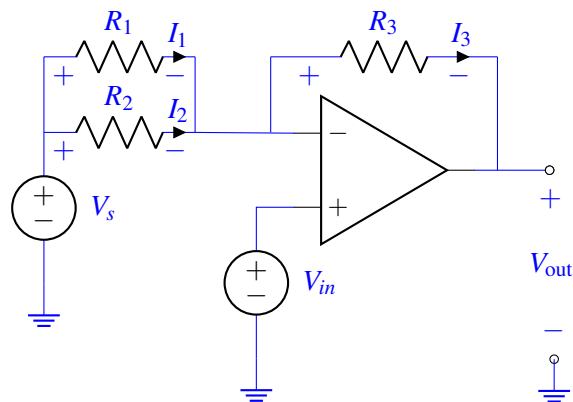

Since our op amp is in negative feedback, we can apply the Golden Rules to find that the voltage at the  $-$  terminal is  $V_{in}$ . Applying KCL, we get:

$$I_1 + I_2 = I_3$$

$$\frac{V_s - V_{in}}{R_1} + \frac{V_s - V_{in}}{R_2} = \frac{V_{in} - V_{out}}{R_3}$$

Plugging in our given values, we get:

**Version 1:**

$$\frac{5 - 6}{1} + \frac{5 - 6}{1} = \frac{6 - V_{out}}{1}$$

$$0 = 8 - V_{out}$$

$$V_{out} = 8V$$

**Version 2:**

$$\frac{5-5}{4} + \frac{5-5}{4} = \frac{5-V_{out}}{4}$$

$$0 = 5 - V_{out}$$

$$V_{out} = 5V$$

**Version 3:**

$$\frac{6-7}{2} + \frac{6-7}{2} = \frac{7-V_{out}}{2}$$

$$0 = 9 - V_{out}$$

$$V_{out} = 9V$$

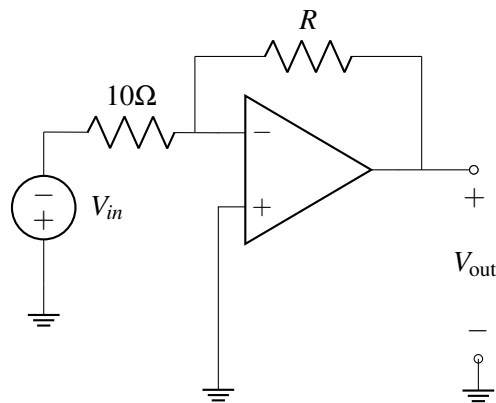
**15. Op Amps (3 points)**

**Version 1:** Alex has a  $V_{in} = 1.1V$  input voltage source, but wants an output  $V_{out} = 4.4V$  to power their Launchpad. They are planning to use the following circuit to implement that.

**Version 2:** Alex has a  $V_{in} = 1.1V$  input voltage source, but wants an output  $V_{out} = 3.3V$  to power their Launchpad. They are planning to use the following circuit to implement that.

**Version 3:** Alex has a  $V_{in} = 1.1V$  input voltage source, but wants an output  $V_{out} = 2.2V$  to power their Launchpad. They are planning to use the following circuit to implement that.

What resistance value  $R$  should Alex choose to get their desired voltage?

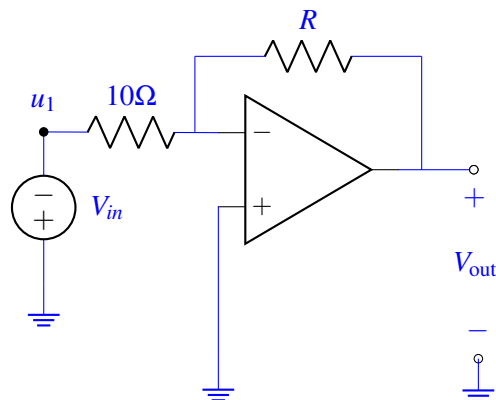
**Solution:**

Note that this circuit is the inverting amplifier op-amp topology, except that we flip the input  $V_{in}$ . From the notes, we know that  $V_{out} = -\frac{R}{10}u_1 = \frac{R}{10}V_{in} = 0.11R$ .

**Version 1:** Thus, in order for  $V_{out} = 4.4V$ , we must have  $R = 40\Omega$ .

**Version 2:** Thus, in order for  $V_{out} = 3.3V$ , we must have  $R = 30\Omega$ .

**Version 3:** Thus, in order for  $V_{out} = 2.2V$ , we must have  $R = 20\Omega$ .

## 16. Comparators (4 points)

For the circuit shown above (left), we aim to find the value of an unknown resistor from the comparator outputs. The right plot shows the measured  $V_{out}$  for  $V_{in}$  ranging from -10V to 10V and

**Version 1:**  $V_s = 4V$

**Version 2:**  $V_s = 3V$

**Version 3:**  $V_s = 1V$

What is the value of the unknown resistor?

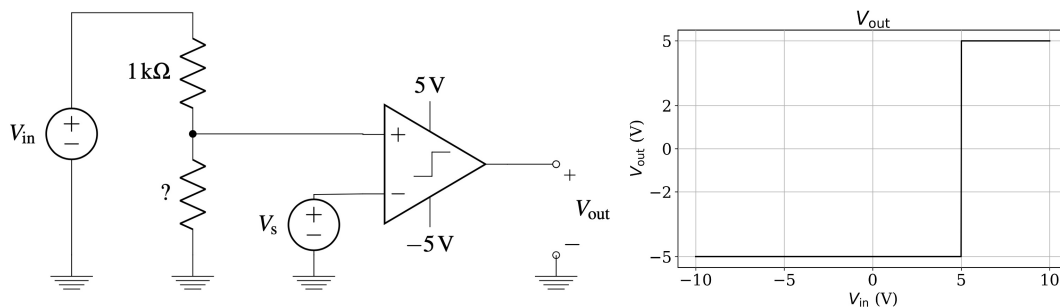

**Solution:** For the comparator in this question, it outputs 5V (positive rail) when  $u_+ > u_-$  and outputs -5V (negative rail) when  $u_+ < u_-$ . Notice that the turning point in the right plot happens when  $V_{in} = 5V$ , which means  $u_+ = u_- = V_s$  when  $V_{in} = 5V$ . Since  $u_+$  is connected to a voltage divider of  $V_{in}$ , we have

$$u_+ = V_{in} \frac{R_?}{1k\Omega + R_?} = V_s.$$

Therefore  $R_? = \frac{1k\Omega \cdot V_s}{V_{in} - V_s}$ .

**Version 1:**  $V_s = 4V, R_? = 4k\Omega$ .

**Version 2:**  $V_s = 3V, R_? = 1.5k\Omega$ .

**Version 3:**  $V_s = 1V, R_? = 0.25k\Omega$

## 17. Comparators 2 (4 points)

Now, we want to find the value of an unknown capacitor using the comparator outputs. For the circuit shown above (left), **Version 1:**  $I_{in} = 1\mu A$ , **Version 2:**  $I_{in} = 3\mu A$ , **Version 3:**  $I_{in} = 0.5\mu A$  and the initial voltage across the capacitor is 0 when  $t = 0$ . The plot of  $V_{out}(t)$  for time  $tt$  from 0-10s is shown on the right. Note that  $\mu = 10^{-6}$ . What is the value of the capacitor?

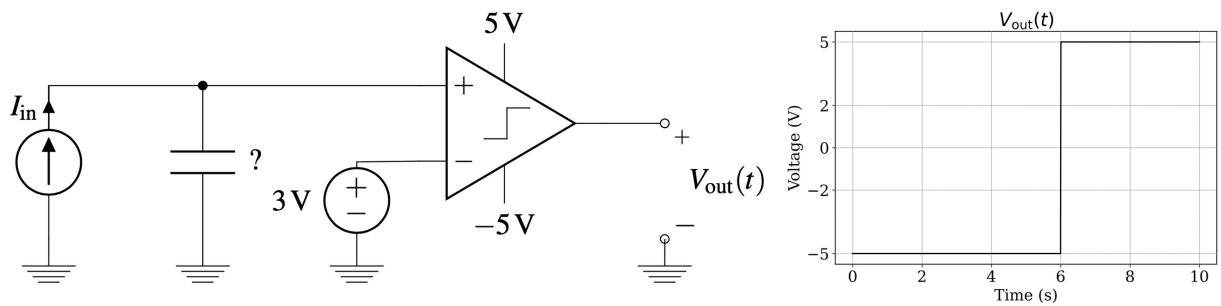

**Solution:** As shown in the left plot, the current source  $I_{in}$  is charging the unknown capacitor  $C$  over time, the charges on  $C$  at time  $t$  equals to the integral of current over time:  $Q_C(t) = \int I_{in} dt = I_{in}t$ . Therefore, we have  $u_+(t) = V_C(t) = \frac{Q_C(t)}{C} = \frac{I_{in}t}{C}$ . The turning point in the right graph is 6s, which means  $V_C(6s) = \frac{I_{in}6s}{C} = u_+ = u_- = 3V$ .

**Version 1:**  $C = I_{in} \frac{6s}{3V} = 2\mu F$

**Version 2:**  $C = I_{in} \frac{6s}{3V} = 6\mu F$

**Version 3:**  $C = I_{in} \frac{6s}{3V} = 1\mu F$

### 18. Superposition (4 points)

Find the current  $i_3$  in the circuit diagram.

**Version 1:** Note that  $V_s=15$  V,  $I_s=4.5$  A,  $R_1=R_2=10$   $\Omega$ , and  $R_3=R_4=5$   $\Omega$ .

**Version 2:** Note that  $V_s=15$  V,  $I_s=6$  A,  $R_1=R_2=10$   $\Omega$ , and  $R_3=R_4=5$   $\Omega$ .

**Version 3:** Note that  $V_s=15$  V,  $I_s=3$  A,  $R_1=R_2=10$   $\Omega$ , and  $R_3=R_4=5$   $\Omega$ .

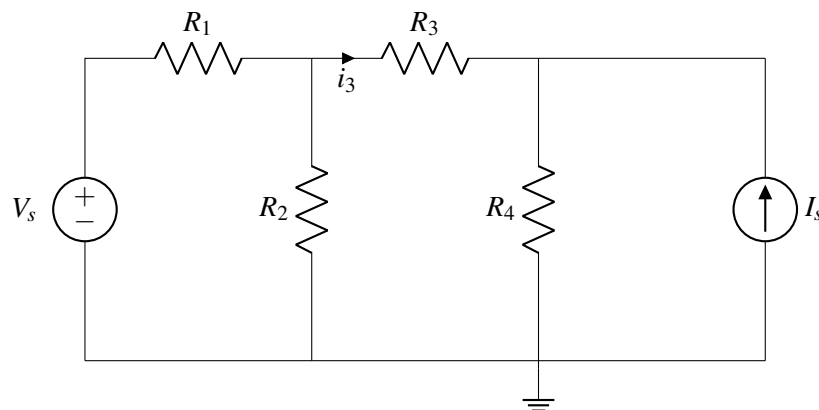

**Solution:** Solve the circuit using superposition.

(a) Zeroing out the current source.

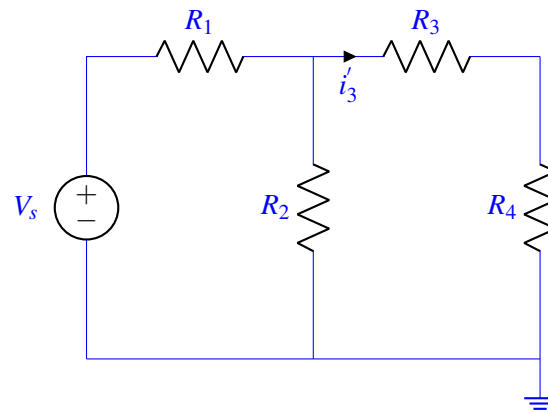

The above circuit is equivalent to:

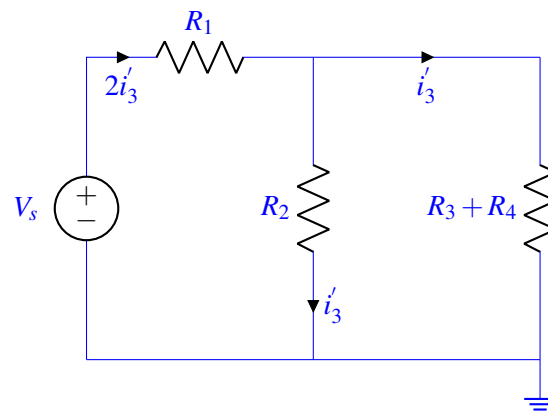

From KVL, we have

$$V_s = R_1 * 2i'_3 + R_2 * i'_3$$

$$15 \text{ V} = 10 \Omega * 2i'_3 + 10 \Omega * i'_3$$

$$i'_3 = 0.5 \text{ A}$$

and this is true for all versions of the problem.

(b) Zeroing out the voltage source:

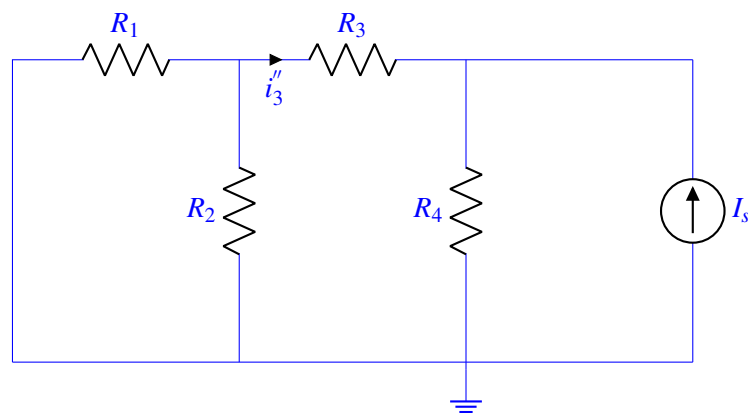

The above circuit is equivalent to:

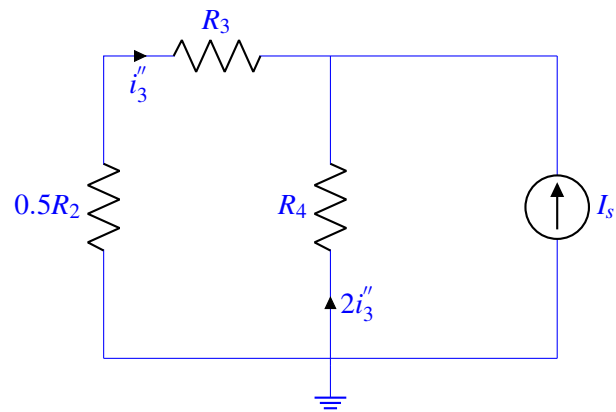

From KCL, we have

$$i_3'' + 2i_3'' + I_s = 0$$

**Version 1:**

$$i_3'' = -1.5 \text{ A}$$

**Version 2:**

$$i_3'' = -2 \text{ A}$$

**Version 3:**

$$i_3'' = -1 \text{ A}$$

Now, applying the principle of superposition, we have

**Version 1:**

$$i_3 = i_3' + i_3'' = 0.5 \text{ A} - 1.5 \text{ A} = -1 \text{ A}$$

**Version 2:**

$$i_3 = i_3' + i_3'' = 0.5 \text{ A} - 2 \text{ A} = -1.5 \text{ A}$$

**Version 3:**

$$i_3 = i_3' + i_3'' = 0.5 \text{ A} - 1 \text{ A} = -0.5 \text{ A}$$



**19. Energy/Power (6 points)**

In the circuit below,

**Version 1:**  $V_s = 5V$ ,  $I_s = 2mA$ , and  $R_1 = 5000\Omega$

**Version 2:**  $V_s = 4V$ ,  $I_s = 2mA$ , and  $R_1 = 4000\Omega$

**Version 3:**  $V_s = 4V$ ,  $I_s = 1.5mA$ , and  $R_1 = 8000\Omega$

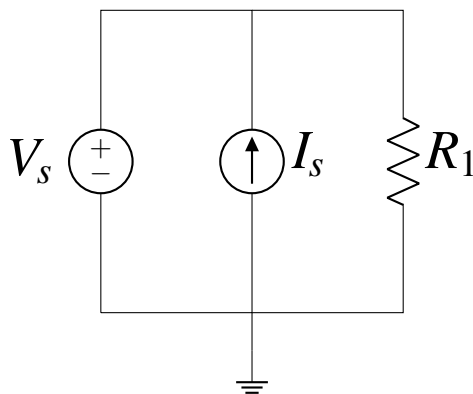

- (a) (2 points) What is the power dissipated by  $R_1$ ?

**Solution:** We can find the power dissipated by a component using the formula  $P = IV$ , where  $P$  is the power,  $I$  is the current through the component, and  $V$  is the voltage across the component. Using Ohm's Law,  $V = IR$ , we can also find power through the equivalent formulas  $P = I^2R$  and  $P = \frac{V^2}{R}$ . In this case, since the component is a resistor whose resistance is given, we might want to use one of the latter formulas. We first notice that the circuit consists of only two nodes, so the voltage drop across all three components is given by the potential at the top node, which we can call  $U_1$  minus the potential at the ground node, 0, which is also the value across the voltage source,  $V_s$ . Thus, the voltage across each of the elements is  $U_1 = V_s$ . Now, we have both  $V$  and  $R$  so we can solve for the power dissipated by  $R_1$  using  $P = V^2/R$ .

**Version 1:**  $P = \frac{V^2}{R} = \frac{5^2}{5000} = 0.005W = 5mW$

**Version 2:**  $P = \frac{V^2}{R} = \frac{4^2}{4000} = 0.004W = 4mW$

**Version 3:**  $P = \frac{V^2}{R} = \frac{4^2}{8000} = 0.002W = 2mW$

- (b) (2 points) What is the power supplied by  $I_s$ ?

**Solution:** Since this is a current source, we will use the formula  $P = IV$ . In this case, we have a current source, so our current is given. We also know the voltage across this current source, which would be the same as the voltage across the resistor that we found in part (a) because they are connected across the same two nodes and are in parallel. Thus, we can use the  $P = IV$  formula to solve for the power supplied by the current source.

**Version 1:**  $P = IV = 2 * 10^{-3} * 5 = 0.01W = 10mW$

**Version 2:**  $P = IV = 2 * 10^{-3} * 4 = 0.008W = 8mW$

**Version 3:**  $P = IV = 1.5 * 10^{-3} * 4 = 0.006W = 6mW$

- (c) (2 points) What is the power dissipated by  $V_s$ ?

**Solution:** Since this is a voltage source, we will use the formula  $P = IV$ . In this case, we have a voltage source, so our voltage is given but we need to current through the voltage source. We can use node voltage analysis to find the current through the voltage source. First, we can write a KCL equation

for the top node and substitute values for the current through the current source and the current through the resistor.

$$I_{V_s} + I_{R1} = I_s$$

$$I_{V_s} = I_s - I_{R1}$$

**Version 1:**  $I_{V_s} = 2mA - 1mA = 1mA$

**Version 2:**  $I_{V_s} = 2mA - 1mA = 1mA$

**Version 3:**  $I_{V_s} = 1.5mA - 0.5mA = 1mA$

Finally, we can use the  $P = IV$  formula to solve for the power dissipated by the voltage source.

**Version 1:**  $P = IV = 1 * 10^{-3} * 5 = 0.005W = 5mW$

**Version 2:**  $P = IV = 1 * 10^{-3} * 4 = 0.004W = 4mW$

**Version 3:**  $P = IV = 1 * 10^{-3} * 4 = 0.004W = 4mW$

Alternatively, we know that the amount of power dissipated in a circuit is equal to the amount of power supplied, or, in other words, that all the power in a circuit sums to zero. Thus, using parts (a) and (b), we can quickly find the power dissipated by the voltage source by subtracting the power dissipated by the resistor from the power supplied by the current source to find the remaining power that must be dissipated by the voltage source.

**Version 1:**  $P = 10mW - 5mW = 5mW$

**Version 2:**  $P = 8mW - 4mW = 4mW$

**Version 3:**  $P = 6mW - 2mW = 4mW$

## 20. Circuit Design (6 points)

In this problem, you are going to design a system that detects a broken wire. The red wire, the wire connecting box y to ground in figures 1 and 2 below, is the wire we are interested in. Figure 1 shows a circuit equivalent of the system in normal operation where the alarm should not be triggered. Figure 2 shows a circuit equivalent of the system where the alarm should be triggered. The broken wire, shown in figure 2, should cause a non-zero voltage drop across box y which will trigger the alarm.

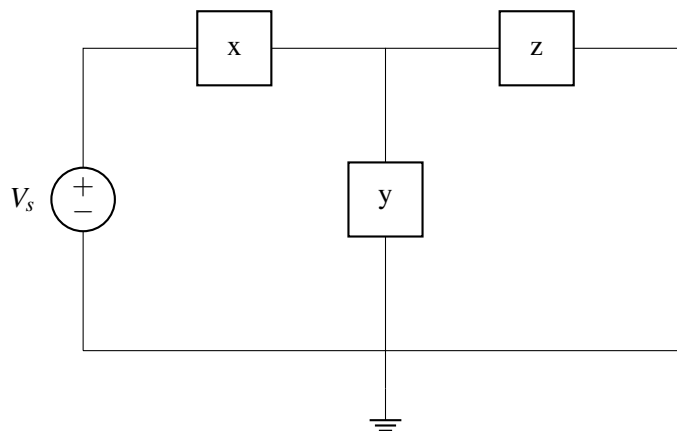

Figure 1: Alarm is off.

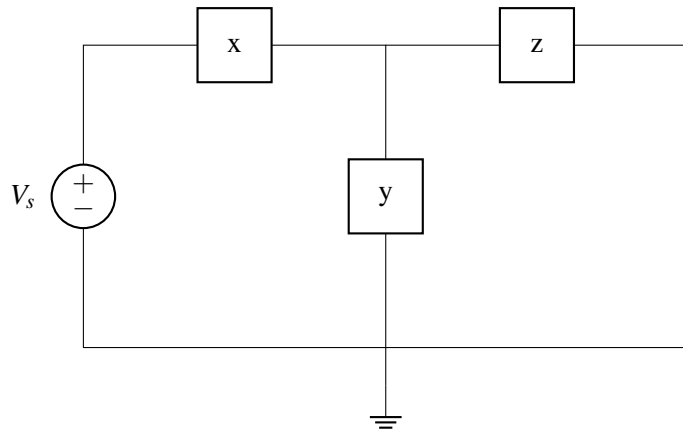

Figure 2: Alarm is triggered.

Given this information, choose the appropriate elements for box1, box2 and box 3 from options (a)-(d). **Note that you are only allowed to use each component once.**

(a) Wire



(b) Alarm

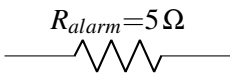

(c) Resistor

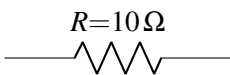

(d) Open circuit



**Solution:** First, let's figure out where to place the alarm. When the wire is broken (Figure 2), the triggered alarm has a non-zero voltage drop. So, the alarm cannot be in box z. box x and box y cannot be open wire. In normal operation (Figure 1), the alarm should not be triggered, which implies the voltage drop across the alarm is zero. So, the alarm cannot be in box x. Therefore, the alarm can only be in box y. Then, let's figure out box x and box z. In normal operation (Figure 1), the voltage drop across the alarm is zero, which means the alarm is shorted. So, box z is a wire. Box x is a resistor to prevent the voltage source from being shorted during normal operation.

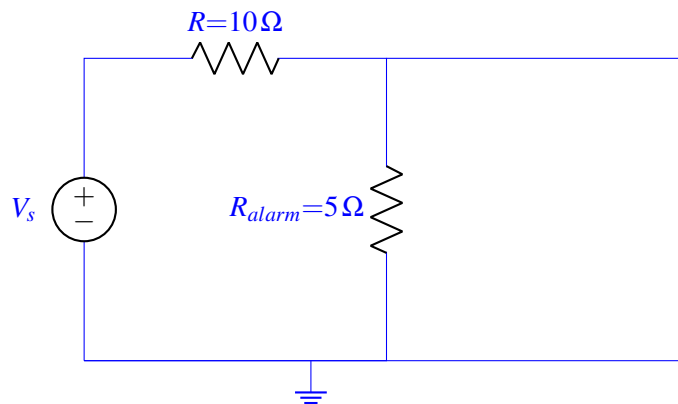

**Final Answers:**

**Version 1:** Box 1 = Box x = (c) Resistor, Box 2 = Box y = (b) Alarm, and Box 3 = Box z = (a) Wire.

**Version 2:** Box 1 = Box y = (b) Alarm, Box 2 = Box z = (a) Wire, and Box 3 = Box x = (c) Resistor.

**Version 3:** Box 1 = Box z = (a) Wire, Box 2 = Box x = (c) Resistor, and Box 3 = Box y = (b) Alarm.

**21. Thevenin and Norton (5 points)**

**Version 1:** Find the Thevenin equivalent voltage and resistance of the given circuit between terminals A and B.

**Version 2:** Find the Norton equivalent current and resistance of the given circuit between terminals A and B:

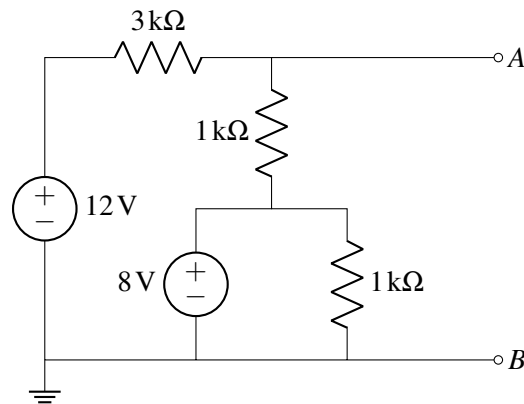

**Solution:** To solve for  $R_{no} = R_{th}$ , we zero out all sources and find the equivalent resistance. In this case, that means converting the voltage sources into wires, which gives the following equivalent circuit:

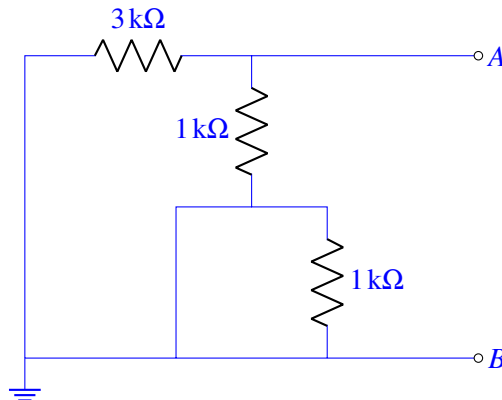

The bottom resistor is shorted, so we can ignore it. Therefore, the equivalent resistance will be  $R_{no} = R_{th} = 3\text{ k}\Omega \parallel 1\text{ k}\Omega = 0.75\text{ k}\Omega$ .

**Version 1:** To solve for  $V_{th}$ , we need to find the open circuit voltage between A and B.

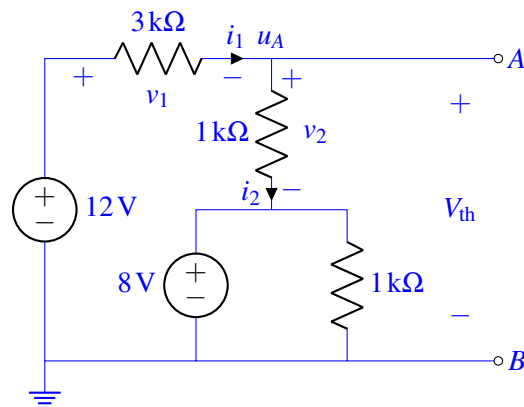

By KCL, we know that  $i_1 = i_2$ . By substituting in Ohm's law, we get that  $\frac{v_1}{3\text{k}\Omega} = \frac{v_2}{1\text{k}\Omega}$ . We can then substitute in for our known and unknown node voltages to get that  $\frac{12\text{V} - u_A}{3\text{k}\Omega} = \frac{u_A - 8\text{V}}{1\text{k}\Omega}$ . From here, we can rearrange to solve for  $u_A$  to get  $u_A = 9\text{V}$ . Therefore,  $V_{\text{th}} = u_A - 0 = 9\text{V}$ .

**Version 2:** To solve for  $I_{\text{no}}$ , we need to find the short circuit current between A and B.

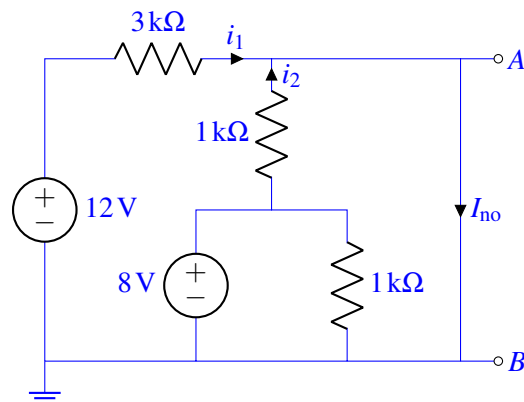

By KCL,  $I_{\text{no}} = i_1 + i_2$ . We can apply Ohm's law to write that  $i_1 = \frac{12\text{V} - 0\text{V}}{3\text{k}\Omega} = 4\text{mA}$ , and  $i_2 = \frac{8\text{V} - 0\text{V}}{1\text{k}\Omega} = 8\text{mA}$ . Therefore,  $I_{\text{no}} = 12\text{mA}$ .

**22. Thevenin and Norton (5 points)**

**Version 1:** You have two circuits. Circuit A can be modeled with  $V_{\text{th}} = 5\text{V}$  and  $R_{\text{th}} = 10\Omega$ . Circuit B can be modeled with  $I_{\text{no}} = 2\text{A}$  and  $R_{\text{no}} = 4\Omega$ .

**Version 2:** You have two circuits. Circuit A can be modeled with  $V_{\text{th}} = 5\text{V}$  and  $R_{\text{th}} = 7\Omega$ . Circuit B can be modeled with  $I_{\text{no}} = 3\text{A}$  and  $R_{\text{no}} = 1\Omega$ .

**Version 3:** You have two circuits. Circuit A can be modeled with  $V_{\text{th}} = 5\text{V}$  and  $R_{\text{th}} = 8\Omega$ . Circuit B can be modeled with  $I_{\text{no}} = 2\text{A}$  and  $R_{\text{no}} = 3\Omega$ .

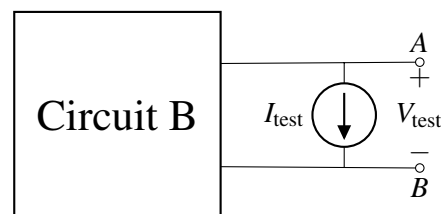
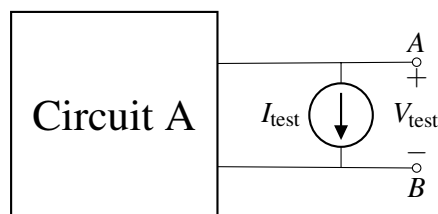

You want to choose a current source with value  $I_{\text{test}}$  so that when you attach the source to each circuit and measure the voltage across it, you find the voltage to be equal to the same value,  $V_{\text{test}}$  in both cases.

You decide to set up a system of equations to solve for  $I_{\text{test}}$  and  $V_{\text{test}}$  in the form  $A\vec{x} = \vec{y}$ , where  $\vec{x} = \begin{bmatrix} I_{\text{test}} \\ V_{\text{test}} \end{bmatrix}$ .

**Version 1:** Your TA Dahlia suggests you use  $\vec{y} = \begin{bmatrix} 5 \\ 8 \end{bmatrix}$ .

**Version 2:** Your TA Dahlia suggests you use  $\vec{y} = \begin{bmatrix} 15 \\ 3 \end{bmatrix}$ .

**Version 3:** Your TA Dahlia suggests you use  $\vec{y} = \begin{bmatrix} 5 \\ 6 \end{bmatrix}$ .

With this value of  $\vec{y}$ , what should you select for the matrix  $A$ ? Do not include units in your answer.

**Solution:** To generate our two equations in this system, we will find the relationship between  $V_{\text{test}}$  and  $I_{\text{test}}$  for each circuit.

For circuit A, we can substitute in our Thevenin equivalent values to get the following circuit:

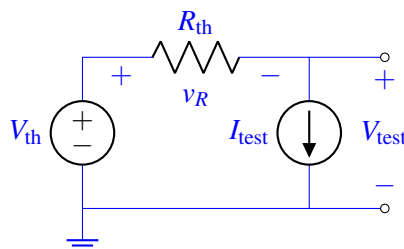

Using KCL, we know that the current going through the resistor must be equal to  $I_{\text{test}}$ , so we can write  $v_R = I_{\text{test}}R_{\text{th}}$ . Additionally, by KVL we can write that  $V_{\text{th}} = v_R + V_{\text{test}}$ , which by substitution becomes  $V_{\text{th}} = R_{\text{th}}I_{\text{test}} + V_{\text{test}}$ . We now have the first equation to our matrix, but we need to scale it so that it matches the given value of  $\vec{y}$ . For versions 1 and 3,  $V_{\text{th}}$  is equal to the first entry of  $\vec{y}$ , so we can fill in this equation as the first row of our matrix where  $a_{11} = R_{\text{th}}$  and  $a_{12} = 1$ . For version 2, the first entry of  $\vec{y}$  is equal to  $3V_{\text{th}}$ , so we need to scale all entries in this row by a factor of 3. Therefore,  $a_{11} = 3R_{\text{th}} = 21$  and  $a_{12} = 3$ .

For Circuit B, we can redraw the situation using a Norton Equivalent circuit:

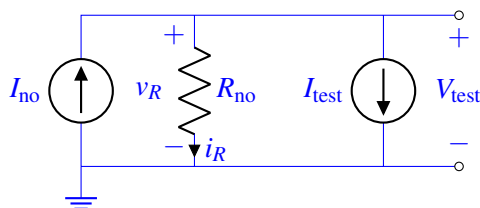

Using KCL, we can write that  $i_R + I_{\text{test}} = I_{\text{no}}$ . Additionally, because  $R_{\text{no}}$  is in parallel to  $i_{\text{test}}$ , we can write that  $v_R = V_{\text{test}}$ . Therefore, with Ohm's law we can write that  $i_R = \frac{V_{\text{test}}}{R_{\text{no}}}$ . Substituting into our KCL equation, we get that  $I_{\text{no}} = I_{\text{test}} + \frac{1}{R_{\text{no}}}V_{\text{test}}$ . Like the previous case, we now need to scale this equation to match the given value of  $\vec{y}$ .

For version 1, we see that the second entry of  $\vec{y}$  is equal to  $4I_{\text{no}}$ , so we need to scale the equation by a factor of 4 to get that  $a_{21} = 4$  and  $a_{22} = \frac{4}{R_{\text{no}}} = 1$ . For version 2, the second entry of  $\vec{y}$  is equal to  $I_{\text{no}}$ , so we don't need to scale the equation. This gives us  $a_{21} = 1$  and  $a_{22} = \frac{1}{R_{\text{no}}} = 1$ . For version 3, The second entry

of  $\vec{y}$  is equal to  $3I_{\text{no}}$ , so we need to scale the entire equation by a factor of 3. This gives us  $a_{21} = 3$  and  $a_{22} = \frac{3}{R_{\text{no}}} = 1$ .

Final Answers:

**Version 1:**

$$A = \begin{bmatrix} 10 & 1 \\ 4 & 1 \end{bmatrix}$$

**Version 2:**

$$A = \begin{bmatrix} 21 & 3 \\ 1 & 1 \end{bmatrix}$$

**Version 3:**

$$A = \begin{bmatrix} 8 & 1 \\ 3 & 1 \end{bmatrix}$$