

The Quest

⚠ This is a preview of the published version of the quiz

Started: Sep 17 at 9:02pm

Quiz Instructions

The Quest is open book. You are allowed to use any lecture/course notes, homeworks, discussions, or websites (except those for collaborative documents or forums). In addition to this, we will allow the use of a calculator and a Python File or Notebook. You may not access or post on any collaborative documents (e.g. Google Docs) or forums (e.g. Chegg). **Collaboration with other students is prohibited.**

Assuming you do not have an approved time extension, you will have 30 minutes to complete the Quest and you may begin the Quest at any point during the window of 7:10-8:00 pm. However, the Quest will close at 8:00 pm, meaning that you must start by 7:30 pm to have the full 30 minutes. **We are not Zoom proctoring.**

We will not clarify anything during the exam so please do your best with the information provided. If you have an issue during your exam please email us at eeecs16b-fa20@berkeley.edu (<mailto:eeecs16b-fa20@berkeley.edu>) and CC the professors (seth.sanders@berkeley.edu (<mailto:seth.sanders@berkeley.edu>)) and mlustig@eeecs.berkeley.edu (<mailto:mlustig@eeecs.berkeley.edu>).

Good luck!

Question 1

4.5 pts

Given the following circuit,

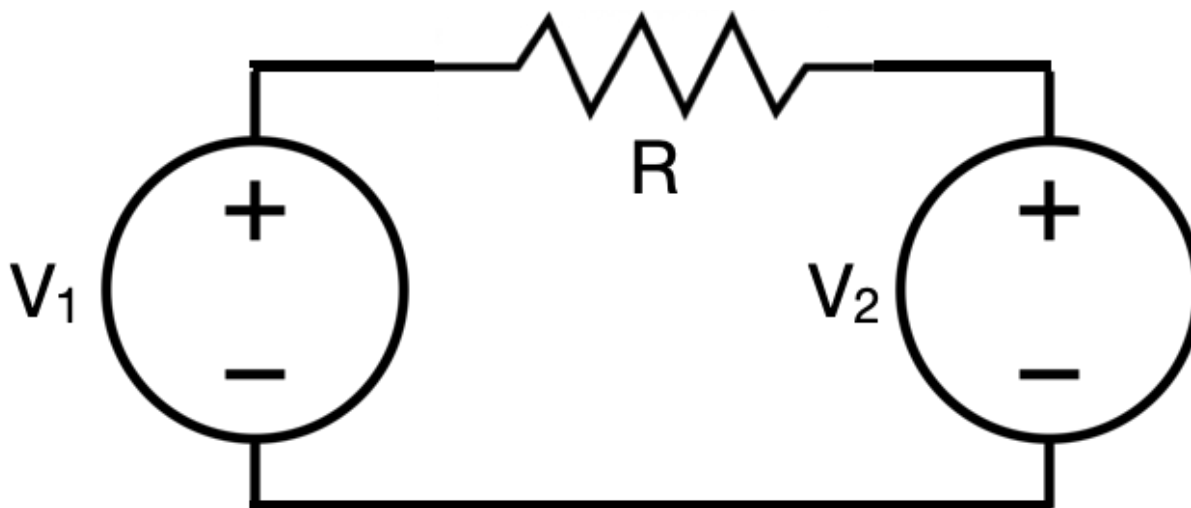

with $R=1\Omega$, $V_1 = 2V$, $V_2 = 1V$.

1) The absolute value of current through the resistor is

Amps.

2) The power in R is

Watts.

3) The power in V1 is

Watts.

4) The power in V2 is

Watts.

An inverter in this question is a device for which $V_{in}=0V$ will result in [REDACTED], and for $V_{in} = V_{dd}$ will result in $V_{out} = 0V$ $V_{out} > 0V$

For each of the following circuits, determine if the circuit is an inverter or not.

Question 2

1.5 pts

Is following circuit an inverter?

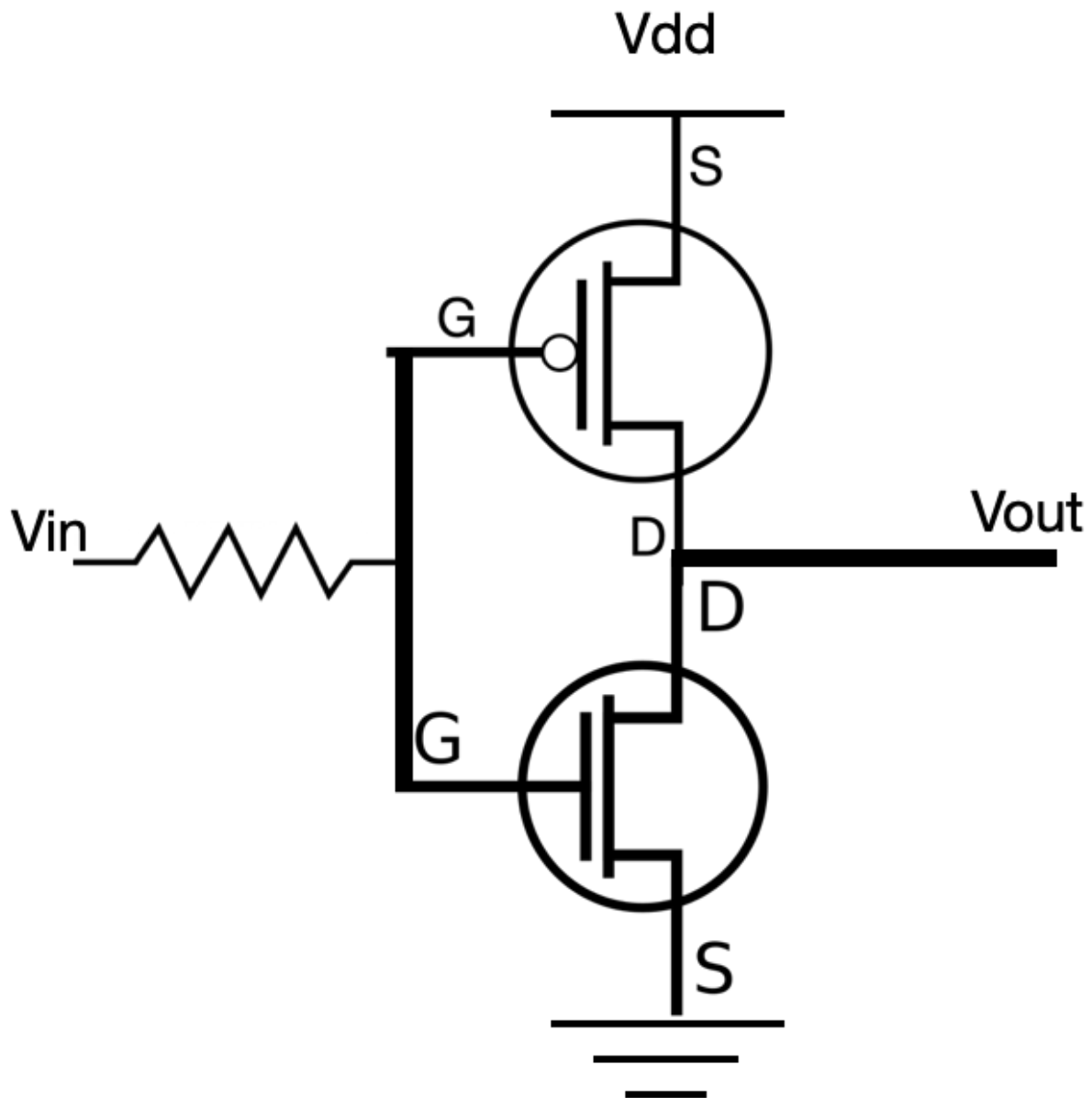

No

Yes

Question 3

1.5 pts

Is following circuit an inverter?

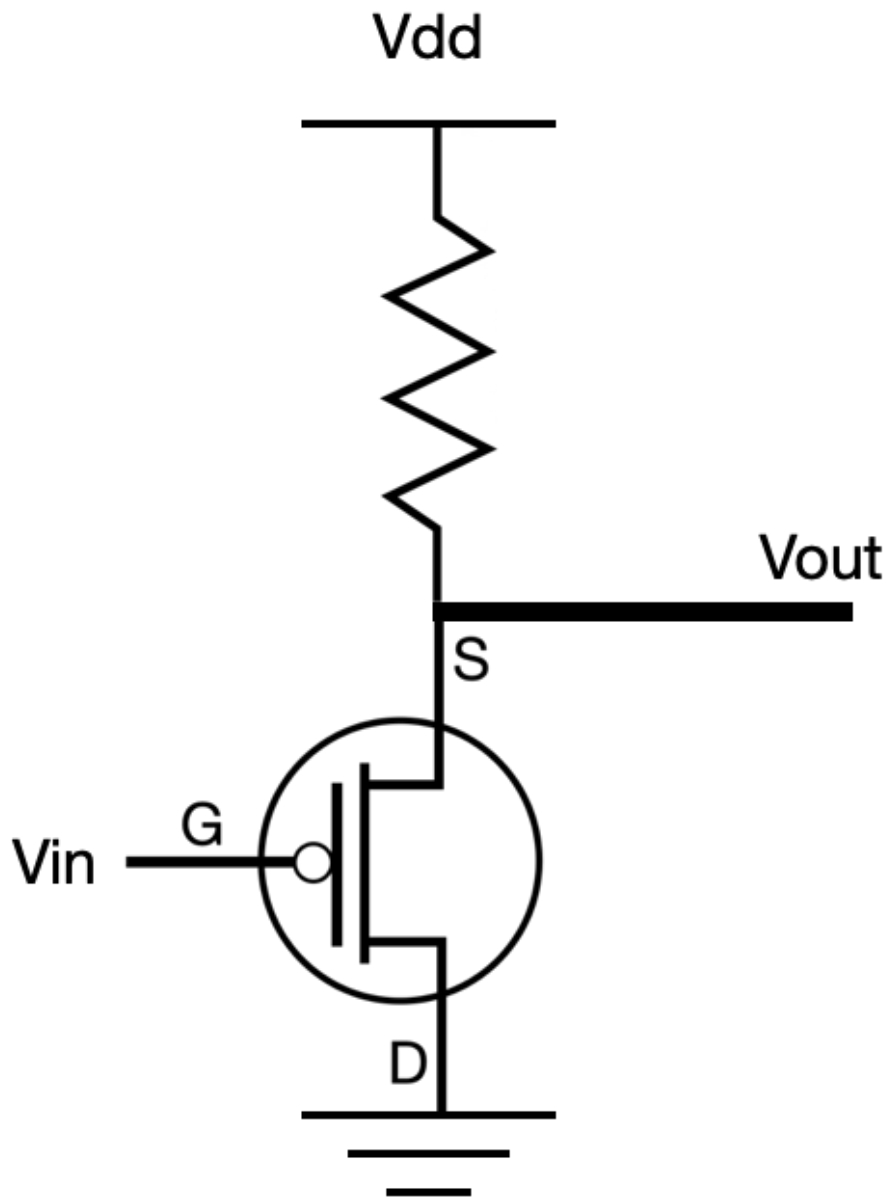

No

Yes

Question 4

1.5 pts

Is following circuit an inverter?

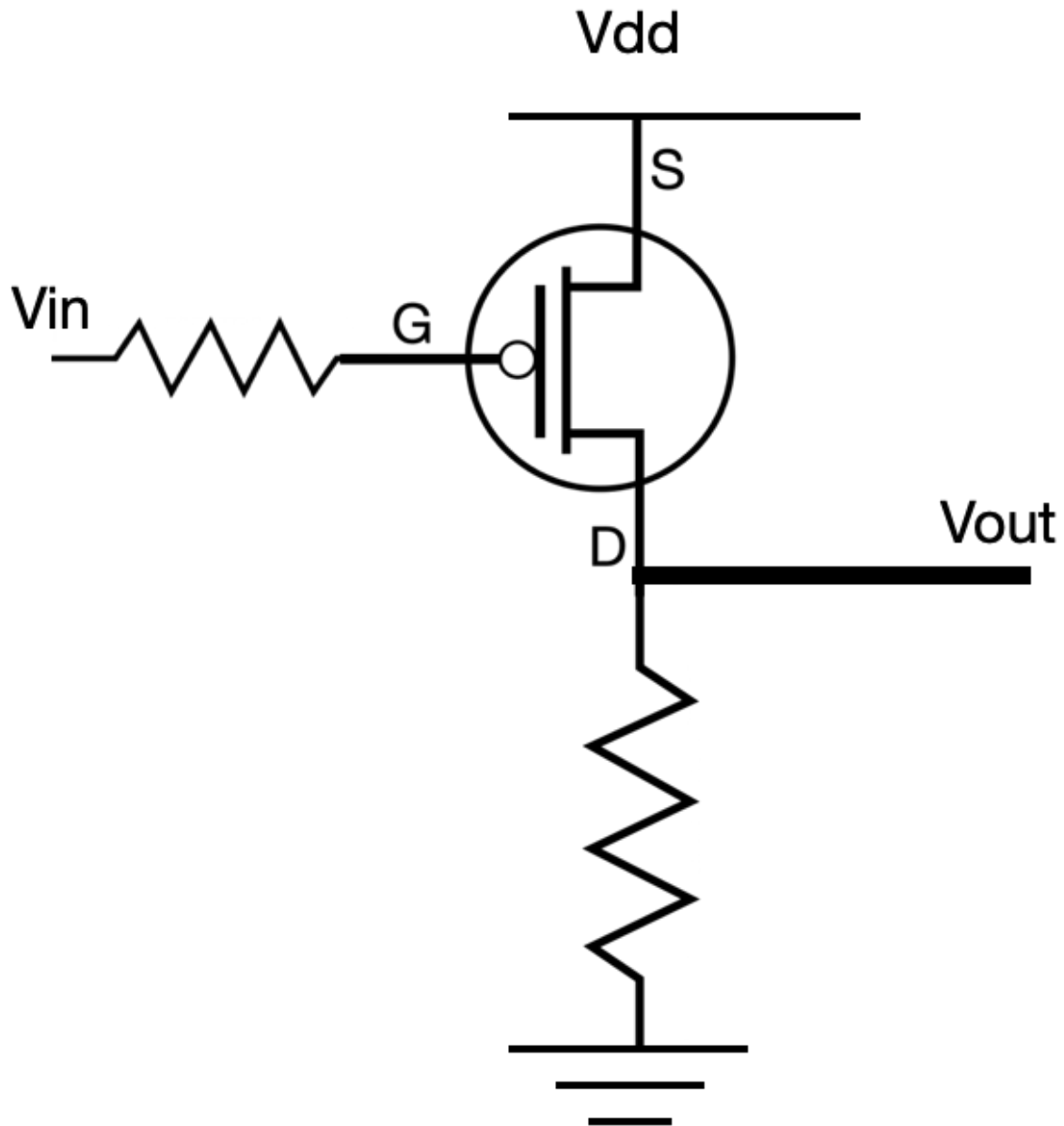

No

Yes

Question 5

1.5 pts

Is following circuit an inverter?

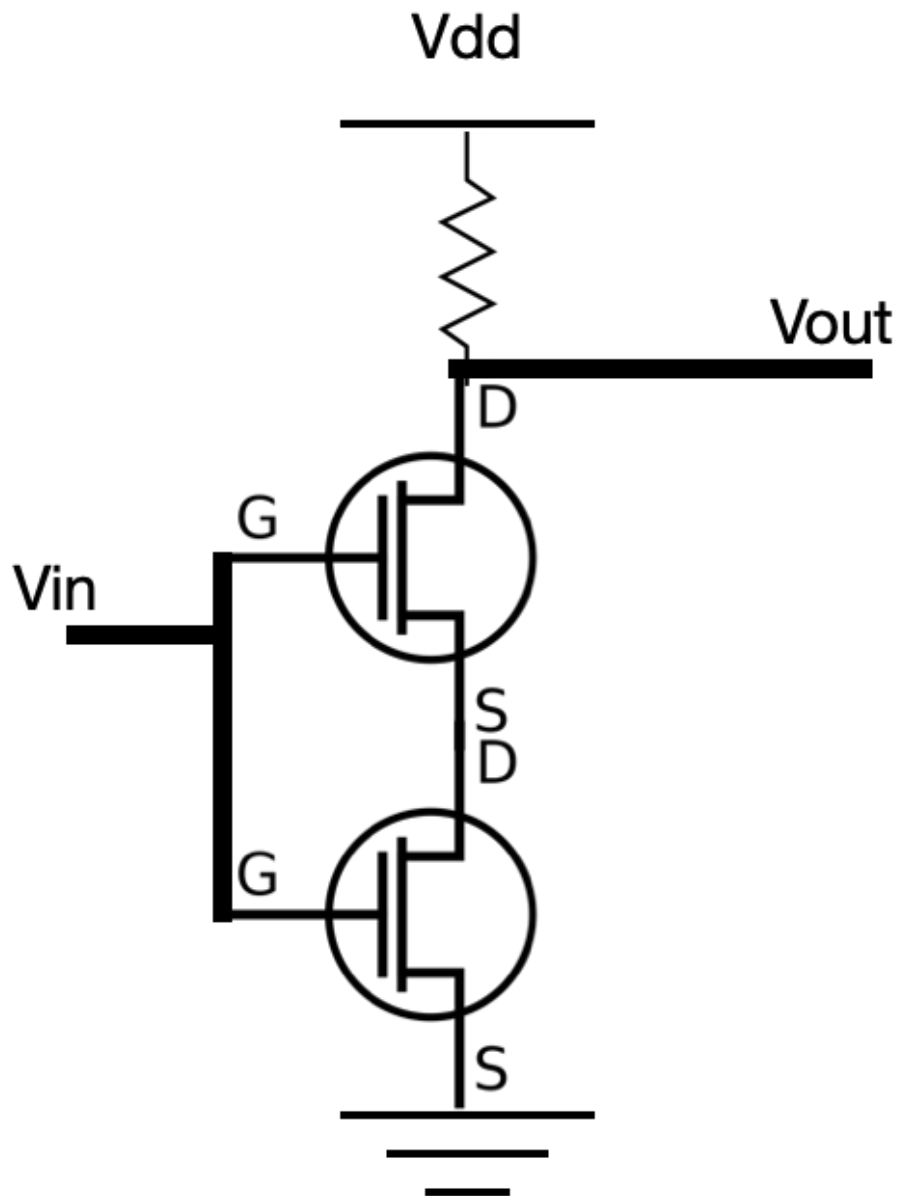

Yes

No

Question 6

4.5 pts

Consider the following circuit, with a transistor switch model (Transistor is a short circuit for $V_{gs} \geq V_{th}$ and open circuit for $V_{gs} < V_{th}$):

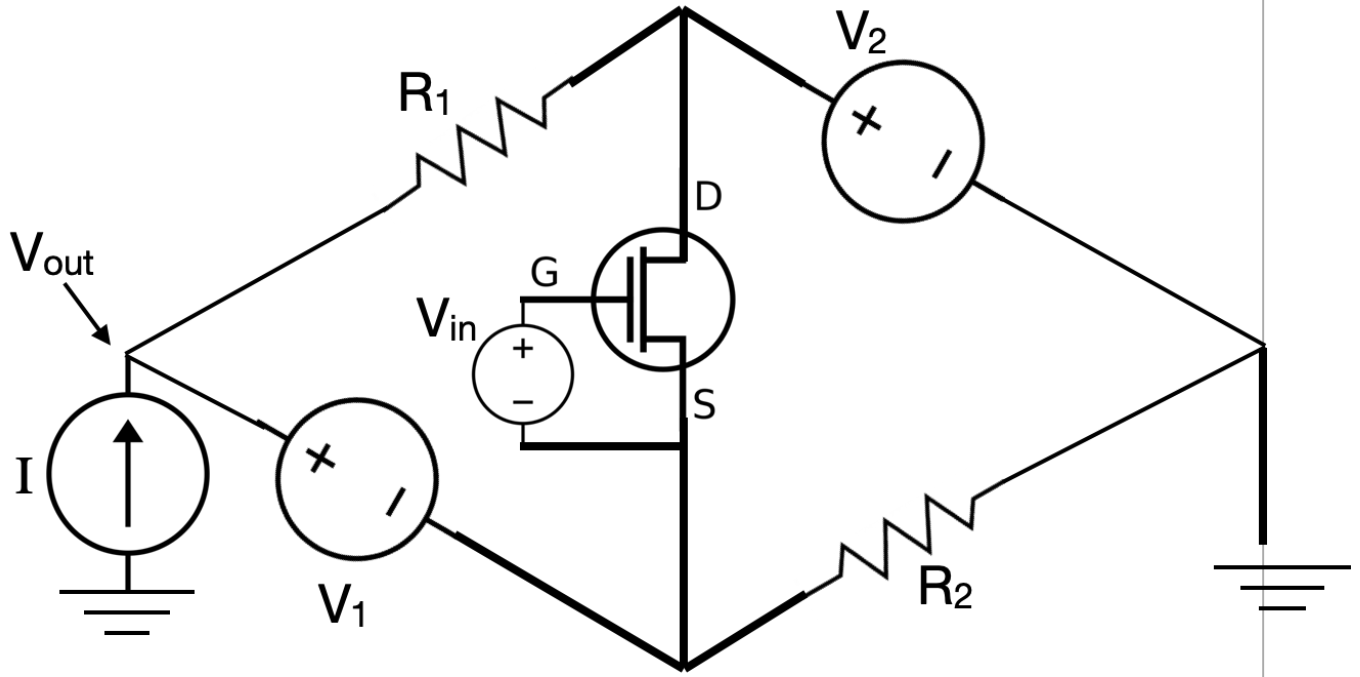

Reference Circuit

Below are several circuits:

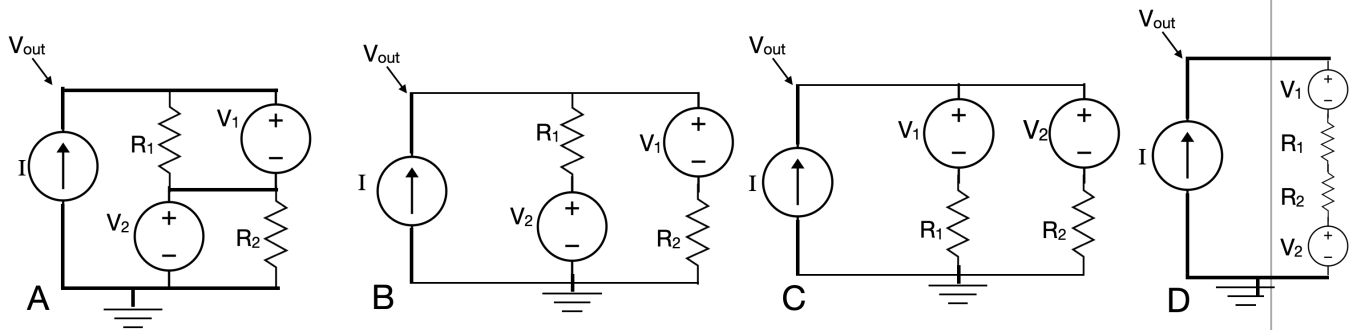

Answer the following questions:

1) Circuit is an equivalent circuit with the same V_{out} as the reference when $V_{in} < V_{th}$

2) Circuit is an equivalent circuit with the same V_{out} as the reference when $V_{in} \geq V_{th}$

The questions below are optional, with no credit (!)

Question 7**0 pts**

- What is your name?

It is , King of the Britons.

- What is your quest?

. (5 words)

- What... is the air-speed velocity of an unladen swallow?

What do you mean? An or swallow?

Quiz saved at 9:03pm