

## 1 RC Circuit Theory

The RC circuit is a fundamental component of any real world circuit. Many electronic systems' specifications, like clock speed and bandwidth, are direct results of RC circuits. We will use differential equation methods to find the time domain behavior of RC systems. We first set up our problem by defining two functions of time:  $I_C(t)$  is the current into the capacitor at time  $t$ , and  $V_o(t)$  is the voltage across the capacitor at time  $t$ .

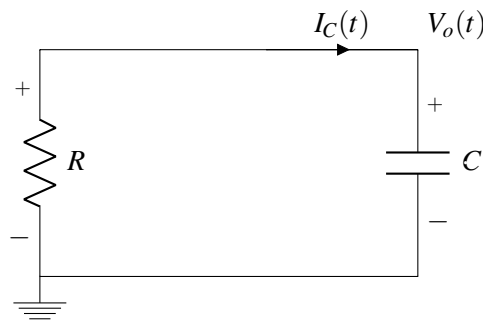

Figure 1: RC Circuit

Let's consider the RC circuit above in Figure 1. Assume that the capacitor is initially fully charged to  $V_{DD}$ . Current will flow out of the capacitor through the resistor: as the current flows out, the charge stored in the capacitor decreases. This causes the voltage across the capacitor to decrease. How can we describe this behavior mathematically?

Real life is continuous, so we need to use differential equations. We'll start with the current across the resistor,  $I_R$ , which is

$$I_R(t) = \frac{V_o(t)}{R}$$

From KCL,  $I_R(t) = I_C(t)$ , and we also know that

$$I_C(t) = C \frac{dV_o}{dt}$$

Equating our expressions for  $I_R(t)$  and  $I_C(t)$ , we get

$$C \frac{dV_o(t)}{dt} = -\frac{V_o(t)}{R}$$

We end up with  $-\frac{V_o(t)}{R}$  because the current through the resistor is flowing against the direction we defined for  $I_C(t)$ .

Rearranging the term, we get

$$\frac{dV_o(t)}{dt} = -\frac{1}{RC} V_o(t)$$

$$\frac{d}{dt}V_o(t) = -\frac{1}{RC}V_o(t)$$

The differentiation operator is a linear operator, so we can view this equation as a linear system  $\mathbf{A}V_o(t) = \lambda V_o(t)$ , where  $\lambda$  is the eigenvalue of the system and  $\mathbf{A}$  is the differentiation operator. Essentially, we need to find a function  $V_o(t)$  that, when operated on by  $\mathbf{A}$ , results in that same function multiplied by a scaling factor. In linear systems, this function is called the eigenfunction of an operator. The eigenfunction of  $\frac{d}{dt}$  is  $Ke^{\lambda t}$ . This means that  $V_o(t)$  is of the form  $Ke^{\lambda t}$ .

When we operate on it with  $\frac{d}{dt}$ , we get

$$\frac{d}{dt}Ke^{\lambda t} = K\lambda e^{\lambda t} = \lambda Ke^{\lambda t}$$

and  $\lambda$  is the corresponding eigenvalue.

In our RC system, the constant  $K$  is defined by the initial conditions and  $\lambda = -\frac{1}{RC}$ . Plugging our eigenvalue into our eigenfunction gives us

$$V_o(t) = Ke^{-\frac{t}{RC}}$$

To solve for  $K$ , we need to take into account the initial conditions of our problem. At  $t = 0$ ,  $V_o(t) = V_{DD}$ , so

$$V_o(0) = Ke^{-\frac{0}{RC}} = V_{DD}$$

$$K = V_{DD}$$

Finally, we have

$$V_o(t) = V_{DD}e^{-\frac{t}{RC}}$$

Now, we can evaluate how long it takes to discharge half the voltage.

$$t_{\text{half life}} = \ln(2)RC \approx 0.693RC$$

The equation is derived by setting  $V_o(t) = \frac{1}{2}V_{DD}$  and solving for  $t$ . We see that bigger the values of  $R$  and  $C$ , the longer it takes for the voltage to drop.  $RC$  is also called the time constant  $\tau$ . It's useful to have a general idea of how many  $\tau$  it takes for a capacitor to reach its final steady state value. After one  $\tau$ , the capacitor voltage is within 36.8% of its final steady state value. After  $5\tau$ , it is within 1% of its final steady state value.

## 2 Charging a Capacitor Dissipates Energy

Suppose that we're charging a capacitor  $C$  with the circuit in figure 2.

Here, the voltage source represents some power supply at voltage  $V_{DD}$ . The resistor  $R$  represents the resistance of the wiring, and the power supply's *internal resistance*. In raising the capacitor voltage from  $V_c = 0$  to  $V_c = V_{DD}$ , we know the capacitor is now storing some energy, namely  $U_c = \frac{1}{2}CV_{DD}^2$ , and that an amount of charge has accumulated on it, namely  $Q_c = CV_{DD}$ .

How much energy did the power supply expend to charge the capacitor? One would certainly hope  $\frac{1}{2}CV_{DD}^2$ , since that's how much is now stored in the capacitor— but this isn't the case. The power supply transferred  $CV_{DD}$  Coulombs of charge into the capacitor, and all of the charge was at the potential  $V_{DD}$  when it left the supply, so the total energy the battery spent was  $E_b = CV_{DD}^2$ . That leaves  $\frac{1}{2}CV_{DD}^2$  of energy unaccounted for. What happened to it? Well, in our model, the only place for it to go is into the resistor, to be burned away as heat.

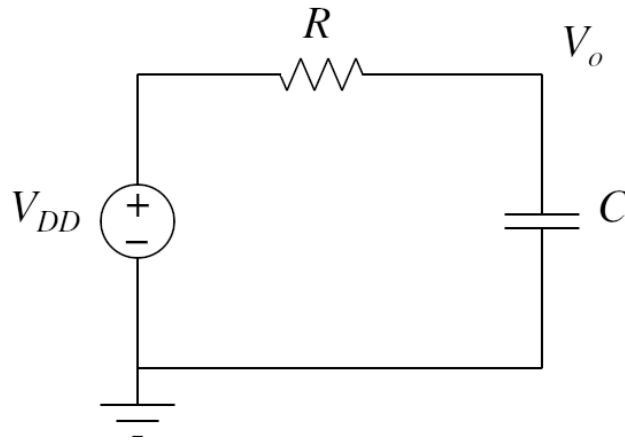

Figure 2: Charging a capacitor with a voltage source.

Now that we have charged the capacitor to  $V_c = V_{DD}$ , suppose that we *discharge* the capacitor by removing the power supply and putting a short circuit in its place. Then the  $\frac{1}{2}CV_{DD}^2$  stored in the capacitor will be dissipated by the resistor. The total power dissipation in the charge-discharge cycle was  $E_{dis} = CV_{DD}^2$ .

Now, suppose that the capacitor is being charged and discharged at some frequency  $f$ . Take  $f = 1$  kHz for instance: then the charge-discharge cycle occurs 1000 times every second. Suppose also that the time constant  $\tau = RC$  for the circuit is short enough that the capacitor has enough time to completely charge and then completely discharge every cycle. Under these conditions,  $CV_{DD}^2f$  of energy is being dissipated every second. Since power is the same as a change of energy per unit time, we say that the *average power* dissipated by charging and discharging the capacitor is

$$P_{dis} = CV_{DD}^2f.$$

## 1. RC Circuits

In this problem, we will be using differential equations to find the voltage across a capacitor over time in an RC circuit. We set up our problem by first defining three functions over time:  $I(t)$  is the current at time  $t$ ,  $V(t)$  is the voltage across the circuit at time  $t$ , and  $V_o(t)$  is the voltage across the capacitor at time  $t$ .

Recall from 16A that the voltage across a resistor is defined as  $V_R = RI_R$  where  $I_R$  is the current across the resistor. Also, recall that the voltage across a capacitor is defined as  $V_o = \frac{Q}{C}$  where  $Q$  is the charge across the capacitor.

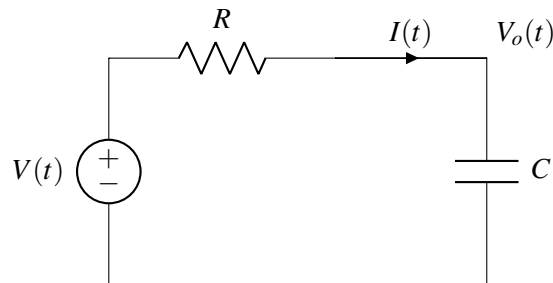

Figure 3: Example Circuit

- (a) First, find an equation that relates the current across the capacitor  $I(t)$  with the voltage across the capacitor  $V_o(t)$ .

- (b) Using Kirchhoff's law, write an equation that relates the functions  $I(t)$ ,  $V_o(t)$ , and  $V(t)$ .
- (c) So far, we have three unknown functions and only one equation, but we can remove  $I(t)$  from the equation using what we found in part (a). Rewrite the previous equation in part (b) in the form of a differential equation.

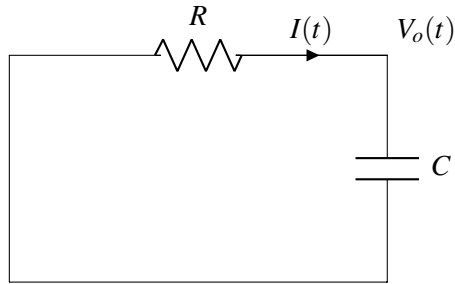

Figure 4: Circuit for part (d)

- (d) Let's suppose that at  $t = 0$ , the capacitor is charged to a voltage  $V_{DD}$  ( $V_o(0) = V_{DD}$ ). Let's also assume that  $V(t) = 0 \forall t \geq 0$ , i.e. shorted to ground. Use the initial condition of  $V_o(t)$  to solve the differential equation for  $V_o(t)$  for  $t \geq 0$ .

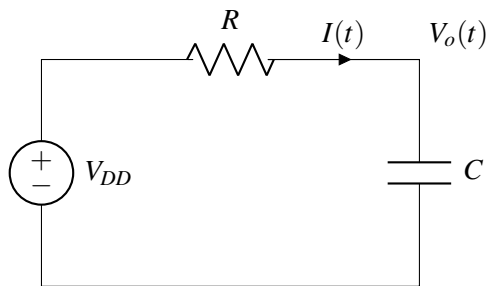

Figure 5: Circuit for part (e)

- (e) Now, let's suppose that we start with an uncharged capacitor  $V_o(0) = 0$ . We apply some constant voltage  $V(t) = V_{DD}$  across the circuit. Solve the differential equation for  $V_o(t)$  for  $t \geq 0$ .

## 2. Power Consumed by Gate Capacitance

A slight refinement to our transistor model is the addition of an *input capacitance*. This is done in the following way:

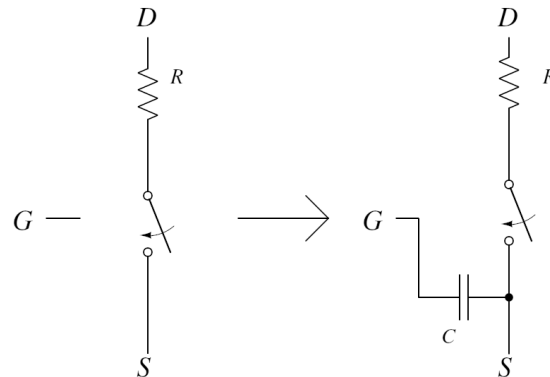

Figure 6: Modeling the gate capacitance of an NMOS transistor

The gate capacitance of transistors in integrated circuits is typically very small, say  $C < 10^{-15}$  F. In many instances this is such a small capacitance that we can just ignore it: this problem looks at an instance where we can't.

In this question, we're going to estimate the total power consumed due to gate capacitance in a CMOS integrated circuit at a specified clock frequency. We'll do this by first calculating the power consumed by the gate capacitor of a single transistor, and then scaling this up by an estimate of the total number of transistors in the integrated circuit.

- Suppose that the clock frequency of the IC is  $f_c = 3$  GHz, and is fed a supply voltage  $V_{DD} = 1$  V. The gate capacitance of a single transistor is  $C = 10^{-15}$  F. Determine the average power consumed by switching the gate capacitance.
- Now, suppose that the integrated circuit contains  $10^9$  transistors, that are all being driven in the same way as the one in part (a). What is the total power consumption? Does it seem likely that this IC uses a modern CMOS technology?

### Contributors:

- Alex Devonport.