

---

EECS 16B    Designing Information Devices and Systems II  
 Spring 2021    UC Berkeley

Homework 5

---

**This homework is due on Friday, February 19, 2021, at 11:00PM. Self-grades and HW Resubmission are due on Tuesday, February 23, 2021, at 11:00PM.**

### 1. Reading Lecture Notes

Staying up to date with lectures is an important part of the learning process in this course. Here are links to the notes that you need to read for this week: [Note 3B](#).

- (a) What is the I-V relationship of an inductor? What is the behavior of the inductor under DC current (i.e. constant current)?

### 2. RLC Responses: Initial Part

Consider the following circuit like you saw in lecture:

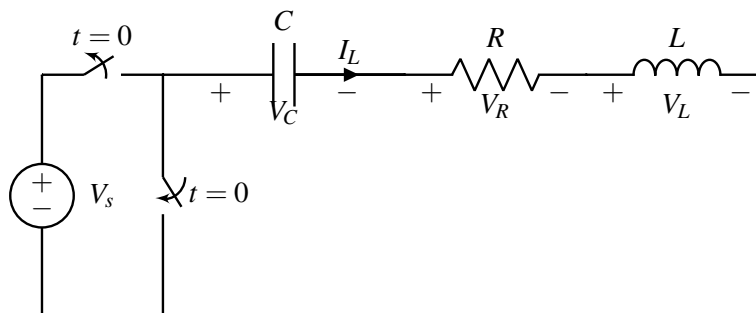

Assume the circuit above has reached steady state for  $t < 0$ . At time  $t = 0$ , the switch changes state and disconnects the voltage source, replacing it with a short.

The sequence of problems 2 - 6 combined will try to show you the various RLC system responses and how they relate to how the eigenvalues of the  $A$  matrix changes. Note that the work you will do will also hold for any second-order system, like a mass-spring-damper, and is very common to study in controls as we'll see later on in Module 2 of the course.

- (a) We first need to construct our state space system. Our natural state variables are the current through the inductor  $x_1(t) = I_L(t)$  and the voltage across the capacitor  $x_2(t) = V_C(t)$  since these are the values that are changing in our circuit. Now, find the system of differential equations in terms of our state variables that describes this circuit for  $t \geq 0$ . Leave the system symbolic in terms of  $V_s$ ,  $L$ ,  $R$ , and  $C$ .

- (b) Write the system of equations in vector/matrix form with the vector state variable  $\vec{x}(t) = \begin{bmatrix} x_1(t) \\ x_2(t) \end{bmatrix} = \begin{bmatrix} I_L(t) \\ V_C(t) \end{bmatrix}$ . This should be in the form  $\frac{d}{dt}\vec{x}(t) = A\vec{x}(t)$  with a  $2 \times 2$  matrix  $A$ .

- (c) Find the eigenvalues of the  $A$  matrix symbolically.  
*(Hint: the quadratic formula will be involved.)*
- (d) Under what condition on the circuit parameters  $R, L, C$  are there going to be a pair of distinct purely real eigenvalues of  $A$ ?
- (e) Under what condition on the circuit parameters  $R, L, C$  are there going to be a pair of purely imaginary eigenvalues of  $A$ ? What will the eigenvalues be in this case?
- (f) Assuming that the circuit parameters are such that there are a pair of (potentially complex when conditions of part (d) fails) eigenvalues  $\lambda_1, \lambda_2$  so that  $\lambda_1 \neq \lambda_2$ , find eigenvectors  $\vec{v}_{\lambda_1}, \vec{v}_{\lambda_2}$  corresponding to them.  
*(HINT: Rather than trying to find the relevant nullspaces, etc., try to find eigenvectors of the form  $\begin{bmatrix} 1 \\ y \end{bmatrix}$  where we just want to find the missing entry  $y$ . This works because we know the first entry of the eigenvector can not be 0 and we want to normalize it so that first entry is 1.)*
- (g) Assuming circuit parameters such that the two eigenvalues of  $A$  are distinct, let  $V = [\vec{v}_{\lambda_1}, \vec{v}_{\lambda_2}]$  be a specific eigenbasis. Consider a coordinate system for which we can write  $\vec{x}(t) = V\tilde{\vec{x}}(t)$ . What is the  $\tilde{A}$  so that  $\frac{d}{dt}\tilde{\vec{x}}(t) = \tilde{A}\tilde{\vec{x}}(t)$ ? It is fine to have your answer expressed symbolically using  $\lambda_1, \lambda_2$ .

### 3. RLC Responses: Overdamped Case

Building on the previous problem, consider the following circuit with specified component values:

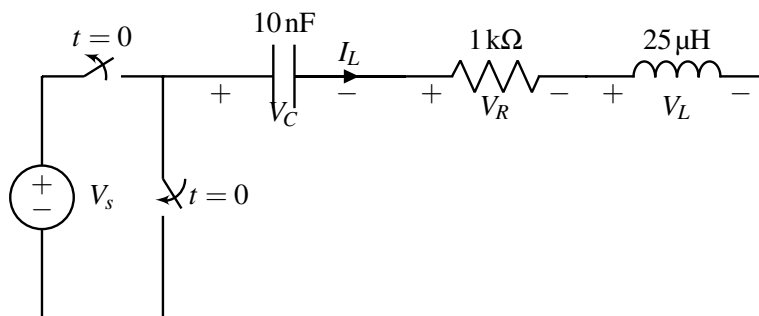

Assume the circuit above has reached steady state for  $t < 0$ . At time  $t = 0$ , the switch changes state and disconnects the voltage source, replacing it with a short.

For this problem, we use the same notations as in Problem 2. You may use a calculator or the attached 'RLC\_Calc.ipynb' Jupyter Notebook for numerical calculations.

- Suppose  $R = 1 \text{ k}\Omega$  and the other component values are as specified in the circuit. Assume that  $V_s = 1$  Volt. Find the initial conditions for  $\tilde{\mathbf{x}}(0)$ . Recall that  $\tilde{\mathbf{x}}$  is in the changed "nice" eigenbasis coordinates from the first problem.
- Continuing the previous part, find  $x_1(t) = I_L(t)$  and  $x_2(t) = V_C(t)$  for  $t \geq 0$ .
- In the 'RLCSliders.ipynb' Jupyter notebook, move the sliders to approximately  $R = 1 \text{ k}\Omega$  and  $C = 10 \text{ nF}$ . Comment on the graph of  $V_c(t)$  and the location of the eigenvalues on the complex plane.

#### 4. RLC Responses: Undamped Case

Building on the previous problem, consider the following circuit with specified component values:

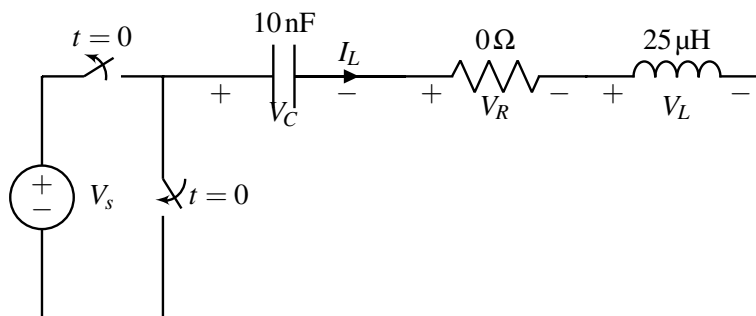

Assume that the capacitor is charged to  $V_s$  and there is no current in the inductor for  $t < 0$ . At time  $t = 0$ , the switch changes state and disconnects the voltage source, replacing it with a short.

For this problem, we use the same notations as in Problem 2. You may use a calculator or the attached 'RLC\_Calc.ipynb' Jupyter Notebook for numerical calculations.

- Suppose  $R = 0\text{k}\Omega$  and the other component values are as specified in the circuit. Assume that  $V_s = 1$  Volt. Find the initial conditions for  $\tilde{x}(0)$ . Recall that  $\tilde{x}$  is in the changed "nice" eigenbasis coordinates from the first problem.
- Continuing the previous part, find  $x_1(t) = I_L(t)$  and  $x_2(t) = V_C(t)$  for  $t \geq 0$ . Remember that your final expressions for  $x_1(t)$  and  $x_2(t)$  should be real functions (no imaginary terms).
- In the 'RLCSliders.ipynb' Jupyter notebook, move the sliders to approximately  $R = 0\Omega$  and  $C = 10\text{nF}$ . Comment on the graph of  $V_C(t)$  and the location of the eigenvalues on the complex plane. Do the waveforms for  $x_1(t)$  and  $x_2(t)$  decay to 0?

Note: Because there is no resistance, this is called the "undamped" case.

## 5. RLC Responses: Underdamped Case

Building on the previous problem, consider the following circuit with specified component values:

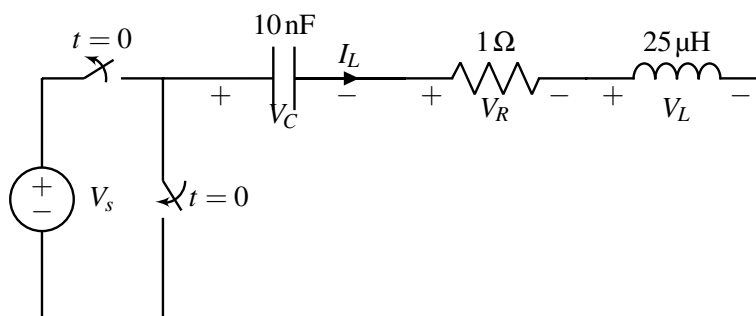

Assume the circuit above has reached steady state for  $t < 0$ . At time  $t = 0$ , the switch changes state and disconnects the voltage source, replacing it with a short.

For this problem, we use the same notations as in Problem 2. You may round numbers to make the algebra more simple. You may use a calculator or the attached 'RLC\_Calc.ipynb' Jupyter Notebook for numerical calculations.

- Now suppose that  $R = 1 \Omega$  and the other component values are as specified in the circuit. Assume that  $V_s = 1 \text{ V}$ . Find the initial conditions for  $\vec{x}(0)$ . Recall that  $\vec{x}$  is in the changed "nice" eigenbasis coordinates from the first problem.
- Continuing the previous part, find  $x_1(t) = I_L(t)$  and  $x_2(t) = V_C(t)$  for  $t \geq 0$ . Remember that your final expressions for  $x_1(t)$  and  $x_2(t)$  should be real functions (no imaginary terms).  
(HINT: Remember that  $e^{a+jb} = e^a e^{jb}$ .)
- In the 'RLCSliders.ipynb' Jupyter notebook, move the sliders to approximately  $R = 1 \Omega$  and  $C = 10 \text{ nF}$ . Comment on the graph of  $V_C(t)$  and the location of the eigenvalues on the complex plane. Do the waveforms for  $x_1(t)$  and  $x_2(t)$  decay to 0?  
Note: Because the resistance is so small, this is called the "underdamped" case. It is good to reflect upon these waveforms to see why engineers consider such behavior to be reflective of systems that don't have enough damping.
- Notice that you got answers in terms of complex exponentials. Why did the final voltage and current waveforms end up being purely real?

## 6. RLC Responses: Critically Damped Case

Building on the previous problem, consider the following circuit with specified component values: (Notice  $R$  is not specified yet. You'll have to figure out what that is.)

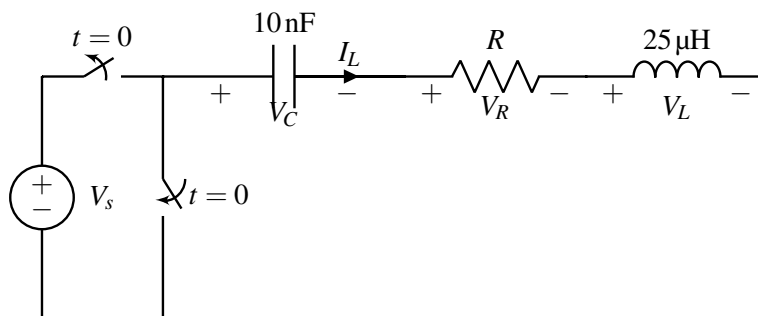

Assume the circuit above has reached steady state for  $t < 0$ . At time  $t = 0$ , the switch changes state and disconnects the voltage source, replacing it with a short.

For this problem, we use the same notations as in Problem 2. You may use a calculator or the attached 'RLC\_Calc.ipynb' Jupyter Notebook for numerical calculations.

- For what value of  $R$  is there going to be a single eigenvalue of  $A$ ?
- Find the eigenvalues and eigenspaces of  $A$ . What are the dimensions of the corresponding eigenspaces? (i.e. how many linearly independent eigenvectors can you find associated with this eigenvalue?)

For this part, assume the given values for the capacitor and the inductor, as well as the critical value for the resistance  $R$  that you found in the previous part. It is easier to do the algebra with a non-symbolic matrix to work with.

- We now create a new coordinate system  $V$ , with the first vector being  $\vec{v}_\lambda$  — the eigenvector you found for the single eigenvalue  $\lambda$  above. For the second vector, just pick  $\vec{v}_2 = \begin{bmatrix} 0 \\ 1 \end{bmatrix}$ . We will see later why we

chose such a vector. We then apply a change of basis to define  $\tilde{x}$  in the transformed coordinates such that  $\vec{x}(t) = V\tilde{x}(t)$ . What is the resulting  $\tilde{A}$  matrix defining the system of differential equations in the transformed coordinates?

- Notice that the second differential equation for  $\frac{d}{dt}\tilde{x}_2(t)$  in the above coordinate system only depends on  $\tilde{x}_2(t)$  itself. There is no cross-term dependence. This happened because we earlier chose  $\vec{v}_2$  such that the transformation  $\tilde{A}$  becomes upper triangular and results in the removal of the cross-dependency. We will later see that in fact, we had many other choices for  $\vec{v}_2$ . Now, compute the initial condition for  $\tilde{x}_2(0)$  and write out the solution to this scalar differential equation for  $\tilde{x}_2(t)$  for  $t \geq 0$ .

- With an explicit solution to  $\tilde{x}_2(t)$  in hand, substitute this in and write out the resulting scalar differential equation for  $\tilde{x}_1(t)$ . This should effectively have a time-dependent input in it.

Note: this is just the differential-equations counterpart to the back-substitution step from Gaussian Elimination in 16A, once you had done one full downward pass of Gaussian Elimination. You went upwards and just substituted in the solution that you found to remove this dependence from the equations above. This is the exact same design pattern, except for a system of linear differential equations.

- Solve the above scalar differential equation with input and write out what  $\tilde{x}_1(t)$  is for  $t \geq 0$ .

(HINT: You might want to look at a problem on an earlier homework for help with this. )

- (g) Find  $x_1(t)$  and  $x_2(t)$  for  $t \geq 0$  based on the answers to the previous three parts.

This particular case is called the “critically damped case” for an RLC circuit. It is called this because the  $R$  value you found demarcates the boundary between solutions of the underdamped and overdamped variety.

- (h) In the ‘RLCSliders.ipynb’ Jupyter notebook, move the sliders to the resistance value you found in the first part and  $C = 10nF$ . Comment on the graph of  $V_c(t)$  and the location of the eigenvalues on the complex plane. What happens to the voltage and eigenvalues as you slightly increase or decrease  $R$ ?

- (i) In part (c) we saw that  $A$  only had one eigenvalue,  $\lambda$ , and one eigenvector,  $\vec{v}_\lambda$ . This meant that we had a choice for  $\vec{v}_2$  in the expression  $V = \begin{bmatrix} \vec{v}_\lambda & \vec{v}_2 \end{bmatrix}$ . We seemingly arbitrarily chose  $\vec{v}_2 = \begin{bmatrix} 0 \\ 1 \end{bmatrix}$ . We

claim that there are many correct choices of  $\vec{v}_2$  that will result in  $\tilde{A} = V^{-1}AV = \begin{bmatrix} a & b \\ 0 & c \end{bmatrix}$  where  $a, c \neq 0$

(i.e. it is upper triangular). Remember, we want  $\tilde{A}$  to be upper triangular so that we have an uncoupled

differential equation for  $\vec{x}_2(t)$ :  $\frac{d}{dt}\vec{x}(t) = \begin{bmatrix} a & b \\ 0 & c \end{bmatrix} \begin{bmatrix} \tilde{x}_1(t) \\ \tilde{x}_2(t) \end{bmatrix} \implies \frac{d}{dt}\tilde{x}_2(t) = c\tilde{x}_2(t)$

In fact, it turns out that we can pick any  $\vec{v}_2$  as long as  $\vec{v}_2 \neq k\vec{v}_\lambda$  for some  $k \in \mathbb{R}$ . We will try and prove this very claim. More concisely, prove the statement below:

**if  $V = \begin{bmatrix} \vec{v}_\lambda & \vec{v}_2 \end{bmatrix}$  and  $\vec{v}_2 \neq k\vec{v}_\lambda$  for some  $k \in \mathbb{R}$ , then  $\tilde{A} = V^{-1}AV = \begin{bmatrix} a & b \\ 0 & c \end{bmatrix}$  where  $a, c \neq 0$**

## 7. Second order ODE perspective on solving the RLC circuit

Consider the following circuit like you saw in lecture, discussion, and the previous few problems:

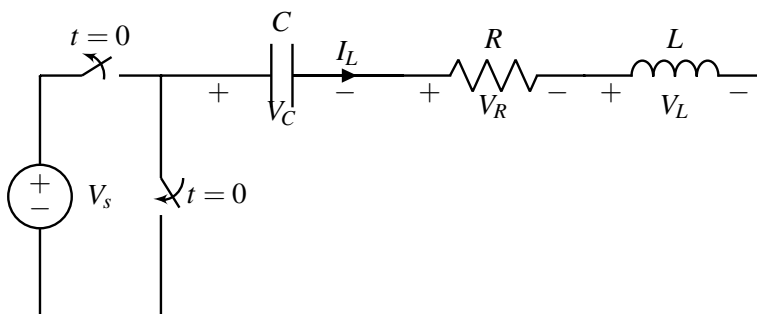

Suppose now we insisted on expressing everything in terms of one waveform  $V_C(t)$  instead of two of them (voltage across the capacitor and current through the inductor). This is called the “second-order” point of view, for reasons that will soon become clear.

For this problem, use  $R$  for the resistor,  $L$  for the inductor, and  $C$  for the capacitor in all the expressions until the last part.

- Write the current  $I_L$  through the inductor in terms of the voltage through the capacitor.
- Now, notice that the voltage drop across the inductor involves  $\frac{d}{dt}I_L$ . Write the voltage drop across the inductor in terms of the second derivative of  $V_C$ .
- For this part, treat  $V_s(t)$  as a generic input waveform — don’t necessarily view the switch as being thrown, etc.

Now write out a differential equation governing  $V_C(t)$  in the form of

$$\frac{d^2}{dt^2}V_C(t) + a \cdot \frac{d}{dt}V_C(t) + b \cdot V_C(t) + c(t) = 0. \quad (1)$$

where  $a$ ,  $b$  and  $c(t)$  are terms you need to figure out by analyzing the circuit.

This is called a second-order system here as there is a 2nd derivative in the differential equation.

(HINT: The  $c(t)$  needs to involve  $V_s(t)$  in some way.)

- We don’t know how to solve equations like Eq. (1). To reduce this to something we know how to solve, we define the first derivative  $\frac{d}{dt}V_C(t)$  as an additional state and label it as  $X(t)$ . Note that this directly gives us one equation in our matrix:  $\frac{d}{dt}V_C(t) = X(t)$ . This leaves us needing an equation for  $\frac{d}{dt}X(t)$ . Express  $\frac{d}{dt}X(t)$  in terms of  $X(t)$ ,  $V_C(t)$ , and  $V_s(t)$ . Write a matrix differential equation in terms of  $V_C(t)$  and  $X(t)$ . Your answer should be in the form:

$$\frac{d}{dt} \begin{bmatrix} X(t) \\ V_C(t) \end{bmatrix} = \underbrace{\begin{bmatrix} ? & ? \\ ? & ? \end{bmatrix}}_A \begin{bmatrix} X(t) \\ V_C(t) \end{bmatrix} + \begin{bmatrix} ? \\ ? \end{bmatrix} \cdot V_s(t). \quad (2)$$

- Find the eigenvalues and eigenvectors of the matrix  $A$  from Eq. (2). Compare what you got to your answers for Problem 2 and explain why this is the case. (Hint: use the same trick you did in problem 2. Don’t do this the hard way.)
- Now use the same values of  $R, L, C$  and initial conditions from Problem 3 and 4 to solve for  $V_C$  in this system. Did you get the same answer as in problems 3 and 4? Remember that you can use the attached ‘RLC\_Calc.ipynb’ to help with computation.



## **8. Homework Process and Study Group**

Citing sources and collaborators are an important part of life, including being a student!

We also want to understand what resources you find helpful and how much time homework is taking, so we can change things in the future if possible.

(a) **What sources (if any) did you use as you worked through the homework?**

(b) **If you worked with someone on this homework, who did you work with?**

List names and student ID's. (In case of homework party, you can also just describe the group.)

**Contributors:**

- Anant Sahai.
- Jaijeet Roychowdhury.
- Sanjeet Batra.
- Aditya Arun.
- Alex Devonport.
- Regina Eckert.
- Kuan-Yun Lee.
- Ashwin Vangipuram.