EECS 16B Designing Information Devices and Systems II

Spring 2021 Note 1: Transistors, Differential Eqns.

1 Introduction to Transistors and RC circuits

Let us motivate this note by understanding the speed of digital computers. We can understand computers as a set of blocks that perform digital logic operations one after the another. You might be familiar with logic in the form of ‘AND’ and ‘OR’ operations in ‘if’ statements while programming. Logic gates are circuits that behave in a manner compatible with those logical operations. For this, high voltages are traditionally used to represent a logical 1 or TRUE and low voltages are traditionally used to represent a logical 0 or FALSE. These logical gate circuits are constructed out of physical devices called transistors. You will learn a lot more about digital circuits and how to construct logical gates out of transistors in 61C.

Here in 16B, we are going to focus on one of the most basic logical blocks: an inverter (or a ‘NOT’ gate). An inverter takes a boolean input and outputs the logical inverse: a 0 (low) maps to a 1 (high) and a 1 (high) maps to a 0 (low). The speed of computers is related to how quickly logical blocks can change their state and thus perform logic (for example, how quickly an inverter can output a 0 after its input changes to a 1). The underlying issues that limit the speed of an inverter are the same issues that impact all logical operations, so to understand what is going on, we will focus on inverters for simplicity.

One of the most basic circuits that we can use to analyze this change is an oscillator, a basic device that oscillates between zero and one. In fact such oscillators are quite common and are used as clocks in all the devices you regularly use! We can analyze the speed and behavior of such oscillators as a basic model to understand the more complex behavior of computers and their speed.

One way to create oscillators is by connecting together an odd prime number of inverters in a loop. Simply connecting an inverter in a loop will misbehave¹. This type of oscillator is called a ring oscillator. By examining the signal in this oscillator after any inverter we can see that the signal must indeed oscillate between 0 and 1. We can create these inverters physically by using transistors as shown below:

¹If we simply have one inverter connected in a loop, we will not have the switching behavior of the oscillator that we desire (depending on if the capacitor is appropriately sized). Since the circuit is fighting between high and low at the output it can stabilize at an intermediate value. In order to allow for oscillations, we need to chain more inverters in a loop. In fact, to prevent undesired behavior, we usually chain together a prime number of inverters. The reason why is related to properties of modulo arithmetic which you will learn in CS70 together with properties of signals studied in EE120.

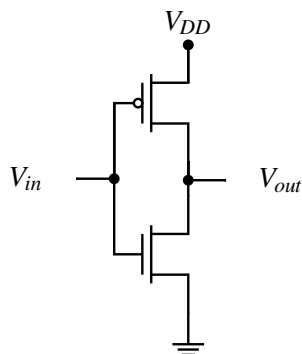

Figure 1: CMOS Inverter

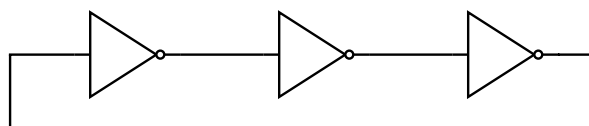

Figure 2: Ring oscillator with 3 inverters

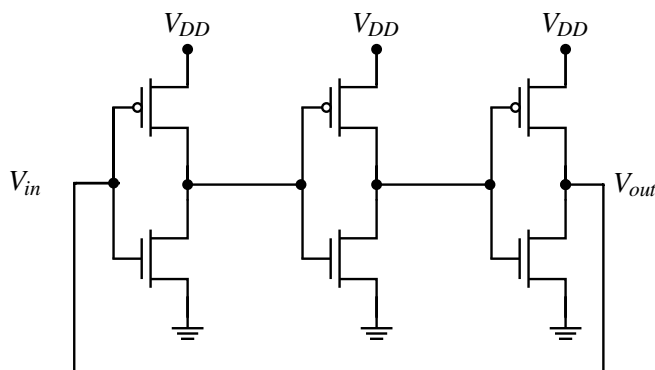

Figure 3: Ring oscillators with 3 CMOS inverters

At their most basic level, transistors can be modeled as switches that change state based on the voltage applied at their gates. There are three terminals on a transistor: a source terminal S , a drain terminal D , and a gate terminal G . As the names imply, the voltage on the Gate terminal determines whether the switch connecting the source and the drain is on (closed) or off (open). The slightly tricky part here comes from understanding "which voltage?" After all, you know from 16A that voltage is physically significant when measured across two points. For transistors, when we talk about the gate voltage, we are talking about the voltage at the gate relative to the voltage at the source. This is usually denoted $V_{GS} = V_G - V_S$.

There are two different kinds of transistors that we look at in what are called CMOS circuits: NMOS transistors and PMOS transistors. We'll get into more details soon, but basically, an NMOS transistor is on if the gate voltage V_{GS} is greater than some small positive threshold V_{tn} . This means that an NMOS transistor is on when the gate voltage is sufficiently higher than the source voltage. The threshold voltage tells us how much higher it needs to be. A PMOS transistor is on if the gate voltage V_{GS} is less than a small *negative* threshold $-V_{tp}$. This means that a PMOS transistor is on when the gate voltage is sufficiently lower than the source voltage. The threshold voltage tells us how much lower it needs to be. Note: because it is easy to get

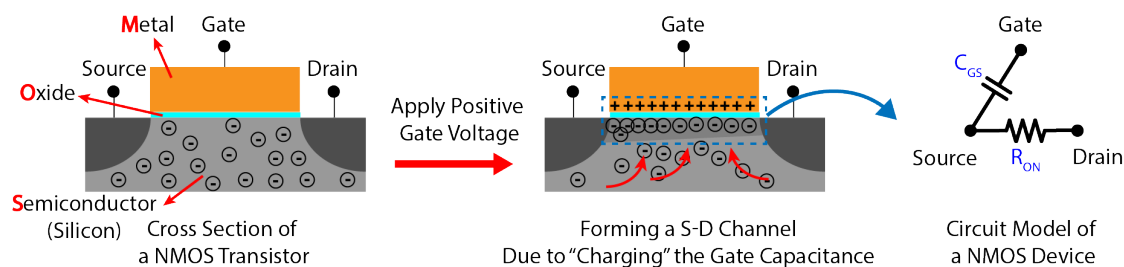

Figure 4: A toy view of a physical transistor to illustrate the "puddle" model of transistor operation. The "puddle" is the group of negative charges that have accumulated on the interface of the semiconductor and the oxide. https://en.wikipedia.org/wiki/Threshold_voltage has an interesting animation that literally shows the "puddle" growing as the gate voltage changes.

tripped up by sign errors when we have negative quantities in expressions where we cannot visibly see the signs, many people prefer to look at $V_{SG} = -V_{GS} = V_S - V_G$ when thinking about PMOS transistors.

At this point, you might be wondering "why do transistors physically behave in this manner?" A true answer to that question is out of scope for this course since it requires a knowledge of physics. However, there is a simple "charge puddle model" that gives you a heuristic sense for why transistors work the way that they do. Look at Figure 4. The idea of this model is that the gate of the transistor is like one terminal of a capacitor with the other part being in the silicon between the source and drain terminals. When the voltage on the capacitor is high enough in the right direction, a "puddle" of charge carriers forms in the silicon to balance out the charge being put on the gate. When the puddle is large enough (hence the finite threshold), it connects the source and the drain, allowing current to flow between them. The "source" is the terminal that can be viewed as where the relevant charge carriers spill from to form the puddle. For NMOS, these carriers are electrons having a negative charge. For PMOS, these carriers are what are called "holes" and they have a positive charge. Actually understanding this properly requires more physics; however, we tell you this just because it might help some of you remember the difference between PMOS and NMOS.

Using the most basic switch model of transistors, each inverter switches instantaneously. If each inverter switched instantaneously, then connecting them in a loop with an odd number of inverters would lead to inconsistent behavior! However, since we can implement this circuit in the real world there is clearly some aspect that we are missing. When such inconsistencies arise in our model, this can be a symptom of failing to properly understand real world behavior. In such cases, the usual approach is to approach the problem with a more detailed model. In this case, the oscillating behavior that we see is actually possible as there is a slight delay between the input and output of the inverters. You can think of these inverters in terms of relays or mechanical switches that are turned on and off by springs. The slight delay while the spring moves the switch from on to off and vice versa is what enables the oscillatory behavior that we see.

Since our simple switch model is not enough to understand this delayed behavior, we adopt a more detailed model for transistors. We model transistors as having some resistance (i.e. the "puddle" doesn't conduct perfectly) and some characteristic capacitance from their gates.² These models are illustrated in Figure 6 and Figure 7. It is important to note what might seem to be a peculiar convention: for NMOS transistors, the source S is on the bottom while for PMOS transistors, the source S is on the top. For our purposes, this is done to make the circuit for an inverter (as well as other logic gates done in CMOS style) more easy to draw on paper. Physically, it is related to the nature of the charge carriers in NMOS vs PMOS transistors.

²When dealing with these circuits in real-world integrated circuits, we also must deal with the capacitance of the wires.

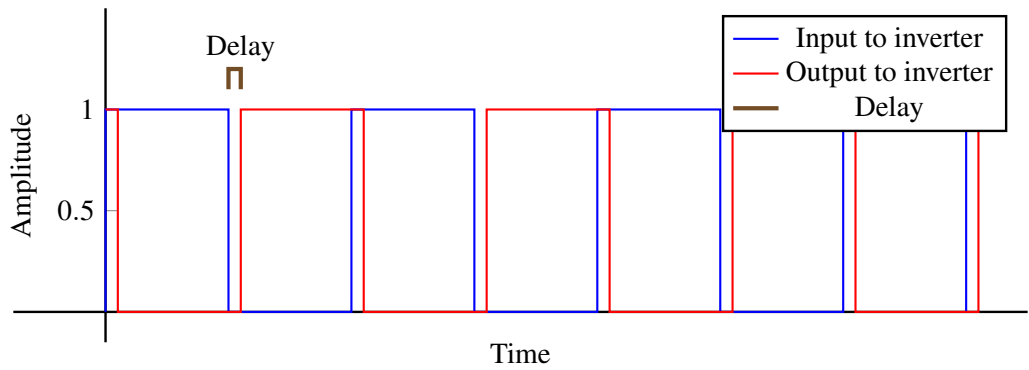

Figure 5: Delay in inverter output for simplified model.

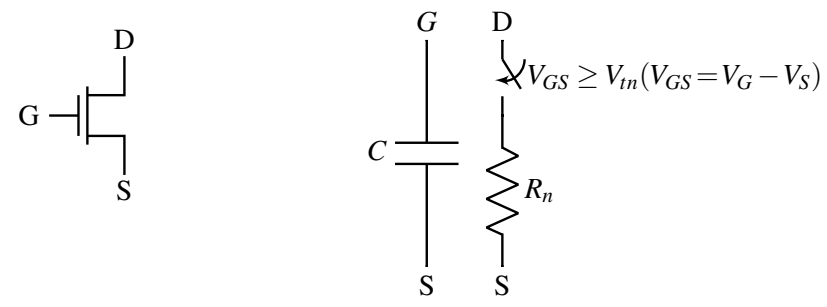

Figure 6: NMOS Transistor Resistor-switch model. The switch is on when V_{GS} is greater than the threshold voltage. Notice the convention: in NMOS Transistors, the Source terminal is at the bottom.

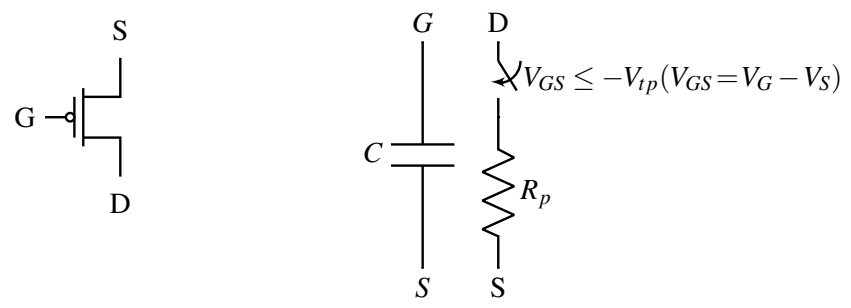

Figure 7: PMOS Transistor Resistor-switch model. The switch is on when V_{GS} is less than the negative threshold voltage. For reasons of human understanding and avoiding sign errors, we will often instead look to see if V_{SG} is greater than $|V_{tp}|$ instead. Notice the convention: in PMOS Transistors, the Source terminal is at the top.

This model for inverters can be used to redraw and analyze our oscillator made out of inverters from Figure 3

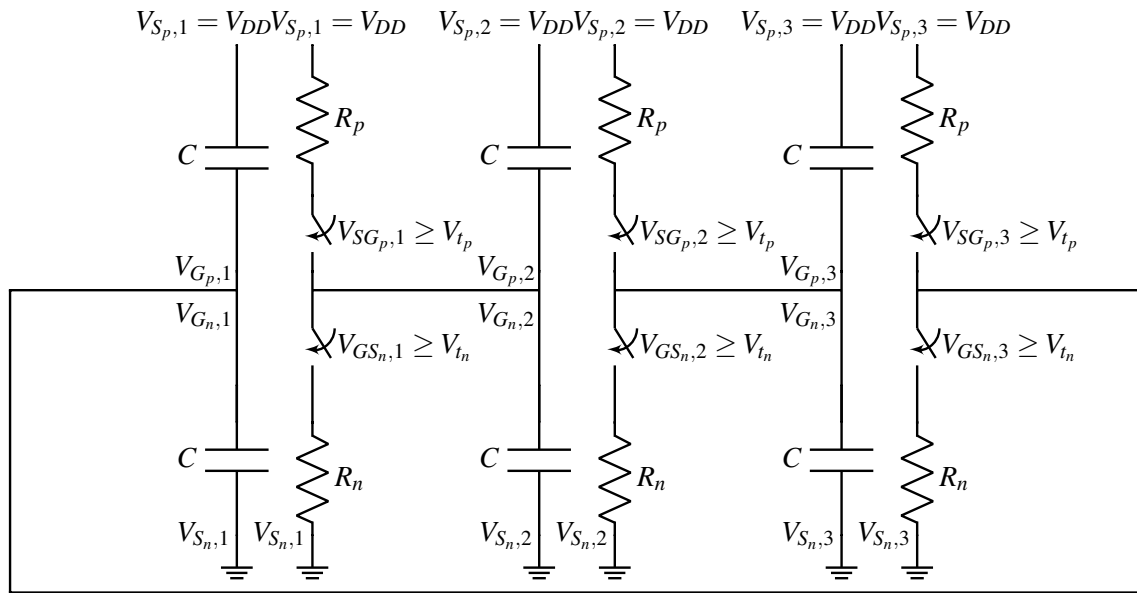

Figure 8: Ring oscillator with detailed transistor model: $V_{GS_n,i} = V_{G_n,i} - V_{S_n,i}$ and $V_{SG_p,i} = V_{S_p,i} - V_{G_p,i}$.

With this model we can see that each inverter drives some capacitance. This means that each inverter is pushing or draining charge from capacitors to cause the output to flip to a '1' or a '0'. To get an idea of how fast it takes for the inverter to change signals, let us examine the case of an inverter in the oscillator where the output started at 1 (high) switching to zero.

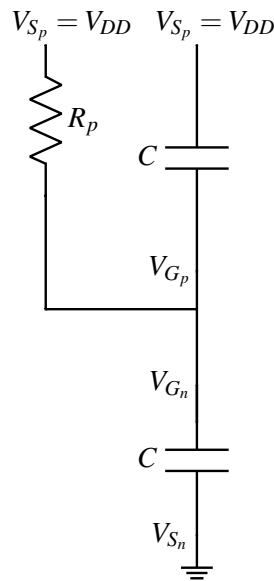

Figure 9: Inverter output at 1

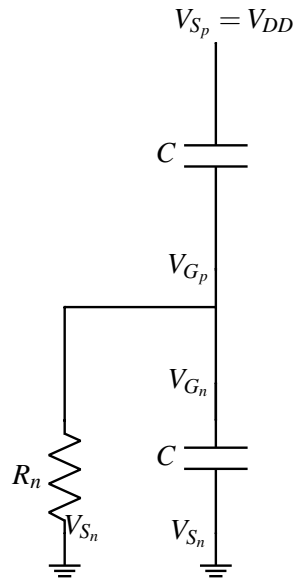

Figure 10: Inverter output at 0

If we condense the circuit down we see that switching the signal involves discharging the capacitor through a resistor. Similarly, if we look at an inverter going from outputting a 0 to outputting a 1, we get a capacitor charging through a resistor. We will show that this behavior is true later in the note. In the next section, we will analyze this with an intuitive approach.

2 Intuitive approach to RC circuits

Going with the example above, let us intuitively examine the voltage on a discharging capacitor over time.

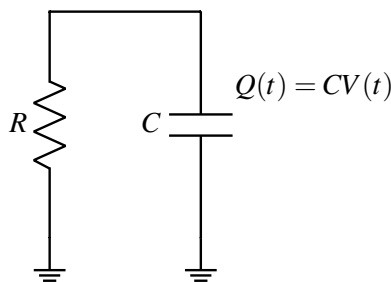

Figure 11: Capacitor discharging through circuit

Let us start out by writing the equations we know from EECS16A:

$$V = IR \tag{1}$$

$$Q = CV \tag{2}$$

Here since we are dealing with voltage and current changing over time we will use $V(t)$ and $I(t)$ in place of V and I to denote this time dependence.

We know that the voltage on the capacitor starts out high at some value we will call V_{DD} . This voltage $V(t)$ is the result of some charge $Q(t)$ on the capacitor. When we discharge the capacitor the charge leaves the capacitor as a current through the resistor and sinks into ground³. As dictated by Ohm's law the current through the resistor is $I(t) = \frac{V(t)}{R}$. If this voltage didn't change, then all the charge CV on the capacitor would drain away in exactly RC seconds. However as charge leaves the capacitor, the actual $V(t)$ decreases and as a result the current $I(t)$ also decreases. This gives us the intuition that as the voltage drops, charge will leave the capacitor at a decreased rate due to the decrease in current. Thus the voltage drop will be a curve falling sharply first and then decreasing at some rate with the decrease in voltage. In fact, the slope on this discharge curve, at any point, will be such that the voltage would reach 0 in RC seconds (time) if we continue along that slope.

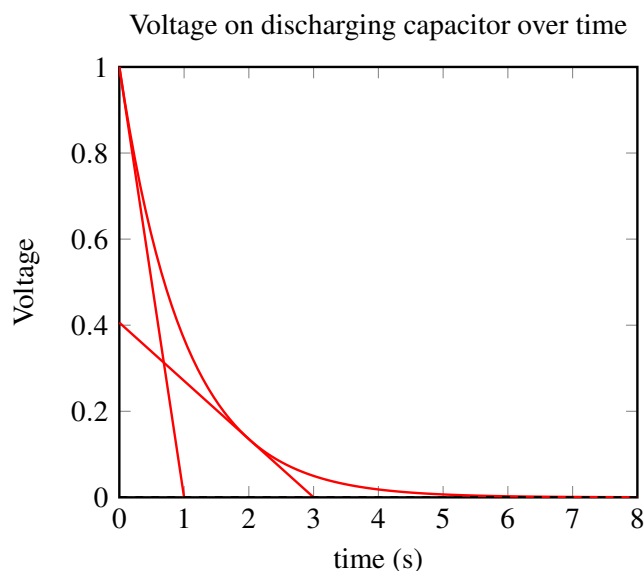

Figure 12: Voltage on capacitor discharging through resistor with RC constant = 1

Now the question arises, what exactly is this curve? Does it have a formula? In the following sections we will use a mathematical approach to solve for $V(t)$ exactly and validate our intuition.

3 Mathematical approach to RC circuits

To begin solving for $V(t)$ let us begin with the following approach that should be a familiar pattern from EECS16A:

- Establish variables for various parts of the circuit
- Utilize KCL (Kirchoff's current law) to establish current equations
- Establish remaining equations (branch equations) with the elements of the circuit

Let us start by establishing variables for the circuit:

³In reality ground is connected to the voltage source and completes a loop.

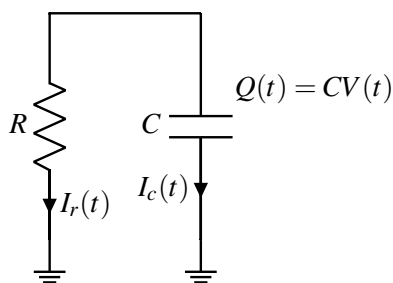

Figure 13: Capacitor discharging through circuit

Let $V(t)$ be the voltage across the capacitor, $Q(t)$ be the charge on the capacitor, $I_c(t)$ be the current flowing through the capacitor to ground, $I_r(t)$ be the current flowing through the resistor to ground, C be the capacitance of the capacitor and R be the resistance of the resistor.

To establish current equations we can focus on the node between the capacitor and resistor. Here we relate the currents to get the equation:

$$I_c(t) = -I_r(t)$$

For the remaining equations let us start by looking at the equation $Q(t) = CV(t)$. This charge, $Q(t)$, starts to leave the capacitor as current through the capacitor which in turn lowers the voltage on the capacitor. Since current is the change in charge over time we differentiate the formula for charge given above to get:

$$\frac{d}{dt}Q = C \frac{d}{dt}V(t) = I_c(t).$$

This gives us the following equations:

$$I_c(t) = C \frac{d}{dt}V(t) \tag{3}$$

$$\frac{V(t)}{R} = I_r(t) \tag{4}$$

$$I_c(t) = -I_r(t) \tag{5}$$

Simplifying the above equations by substitution we get:

$$\frac{d}{dt}V(t) = \frac{-V(t)}{RC}. \tag{6}$$

At first glance it seems like we have one equation and two unknowns: $\frac{d}{dt}V(t)$ and V . Normally we would not be able to make much progress with such a set up, however, these two unknowns are actually related by $\frac{d}{dt}$, the derivative operator. We can use this information to help arrive at a solution. An equation of this form, that relates the derivative of a function to something, is called a differential equation. We will learn how to solve it in the next section.

Now that we have derived an equation for a discharging capacitor we can show how our inverter output switching from 1 to 0 behaves like a discharging capacitor.

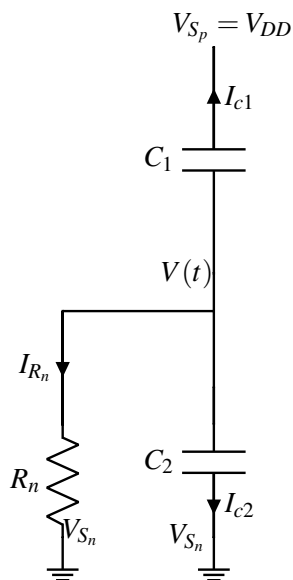

Figure 14: Inverter output at 0

In Figure 14 the inverter has just switched from outputting 1 to outputting 0. This means that the voltage $V(t)$ started at V_{DD} and decreases to 0 at steady state. We know the voltage across C_1 is $V(t) - V_{DD}$ and the voltage across C_2 is $V(t)$. Using this information we can set up a differential equation to solve for $V(t)$:

$$I_{c1} = C_1 \frac{d}{dt}(V(t) - V_{DD}) \quad (7)$$

$$I_{c2} = C_2 \frac{d}{dt}V(t) \quad (8)$$

$$I_{R_n} = \frac{V(t)}{R_n} \quad (9)$$

$$I_{c1} + I_{c2} + I_{R_n} = 0 \quad (10)$$

$$C_1 \frac{d}{dt}(V(t) - V_{DD}) + C_2 \frac{d}{dt}V(t) + \frac{V(t)}{R_n} = 0 \quad (11)$$

$$C_1 \frac{d}{dt}(V(t) - V_{DD}) + C_2 \frac{d}{dt}V(t) = -\frac{V(t)}{R_n} \quad (12)$$

$$C_1 \frac{d}{dt}V(t) + C_2 \frac{d}{dt}V(t) = -\frac{V(t)}{R_n} \quad (13)$$

$$(C_1 + C_2) \frac{d}{dt}V(t) = -\frac{V(t)}{R_n} \quad (14)$$

$$\frac{d}{dt}V(t) = -\frac{V(t)}{R_n(C_1 + C_2)} \quad (15)$$

This is exactly the same form of differential equation that we got for the discharging capacitor circuit with just a different value for capacitance! Thus we have shown that we can boil this inverter circuit down to a capacitor discharging through a resistor! (You can take a similar approach to show that an inverter that switches from 0 to 1 is akin to charging a capacitor through a resistor).

4 Differential equations

4.1 Simple scalar differential equations

Differential equations relate functions to their own derivatives. In this note, we will learn to solve simple first order scalar differential equations. To begin let us start with the simple example of:

$$\frac{d}{dt}x(t) = b$$

Here b is a particular given constant. If you recall from high school calculus to find x we can integrate both sides with respect to t :

$$\int \frac{d}{dt}x(t)dt = \int bdt \quad (16)$$

$$x(t) = bt + k_1 \quad (17)$$

where k_1 is any arbitrary constant.

We can check to see that this indeed satisfies $\frac{d}{dt}x(t) = b$ by calculating $\frac{d}{dt}x(t) = \frac{d}{dt}(bt + k_1) = \frac{d}{dt}(bt) + \frac{d}{dt}(k_1) = b + 0 = b$.

Recall from calculus that we resolved this ambiguous constant through definite integrals, where the bounds of integration were specified. When solving circuits or other problems involving differential equations, the definite integral approach is not always the most natural. This is because we instead often see this ambiguity-resolving information physically manifest as specific values for voltages or other state variables at a certain point in time. We will further discuss solving for the unknown constants in upcoming sections. Though the example here utilized a constant this method can be extended to differential equations of the form $\frac{d}{dt}x(t) = f(t)$ where $f(t)$ is any function that we can integrate.⁴

4.2 "Homogeneous" differential equations

Next, we work to extend this beyond $\frac{d}{dt}x(t) = f(t)$ to the more general first order differential equations of the form $\frac{d}{dt}x(t) = ax(t) + b$ where a and b are constants (In the context of circuits you will see that b will be the effect of voltage and current sources). We always want to start by thinking about the simplest case of the problem. Let us start by setting $b = 0$ with what are called homogeneous first order differential equations. The name isn't important, but this gives us $\frac{d}{dt}x(t) = ax(t)$ which feels simpler than the general form of such differential equations. In fact this equation is exactly like $\frac{d}{dt}V(t) = \frac{-V(t)}{RC}$, the differential equation for the voltage on a discharging capacitor, where $a = -\frac{1}{RC}$.

The format of this equation should remind you of eigenvalues you saw in EECS16A. There we saw $Ax = \lambda x$. This parallels $\frac{d}{dt}x(t) = ax(t)$, where the derivative (a linear operator), akin to the linear matrix operator, acts on some function $x(t)$ to give the same function $x(t)$ times some constant a .

Thus, intuition tells us that we should look for "eigenfunctions" of the derivative operator. In other words we need a function whose derivative equals itself times some constant. Recall that the function e^{at} satisfies

⁴The integration we refer to here is normal Riemann integration that you learned in high school; however, there are some cases, that are important in EECS and beyond the scope of this class, where you will also encounter Lebesgue integration. It is important also to realize that the only reason this "anti-derivative" approach to solving this kind of simple differential equation is valid is because you have proved the fundamental theorem of calculus in your basic calculus courses. Without that theorem, the use of integration here is nothing more than a heuristic.

this property perfectly! Furthermore, recall that when we solved for eigenvectors, we found an eigenspace where any linear combination of eigenvectors corresponding to a eigenvalue constituted a valid eigenvector. Similarly, here we see that, with the information given, any multiple of e^{at} satisfies the differential equation. Hence, one solution will be in the form of $x(t) = k_2 e^{at}$ where k_2 can be any constant. Thus for our RC circuit, the solution should be something like $x(t) = k_2 e^{-\frac{t}{RC}}$.

So far, what we have done here is simply a form of glorified guessing. This is because while the eigenvalue/eigenvector idea above can be made rigorous (by appropriately and carefully defining the relevant infinite-dimensional vector spaces and linear operators on them), we haven't done so. We are just reasoning by analogy here. Anything obtained purely by analogy is just an educated guess. So we need to check to see if this guess is even a solution to the differential equation.

Let us validate by taking the derivative of $x(t)$:

$$\frac{d}{dt} k_2 e^{-\frac{t}{RC}} = \frac{-1}{RC} k_2 e^{-\frac{t}{RC}} \tag{18}$$

And it turns out that this worked!

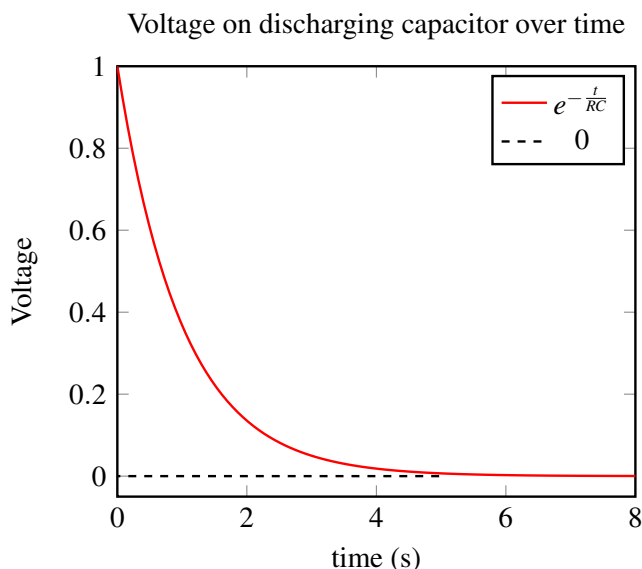

Figure 15

Uniqueness

Now that we have found a set of potential solutions, the other question that arises is whether there is a unique solution to the differential equation that we are solving. In both the cases above:

$$x = bt + k_1 \tag{19}$$

$$\frac{d}{dt} k_2 e^{at} = ak_2 e^{at} \tag{20}$$

we had an infinite number of solutions, as the constants k_1, k_2 in question could take any value and still satisfy the differential equation. We faced a similar issue when solving for voltages in a circuit in EECS16A. In EECS16A we always had one free variable and all the voltages that we solved were relative to that free variable. In order to properly solve for unique voltages in our circuit, we needed more information about

this free variable. This free variable was the ground that we were either given or arbitrarily placed in our circuit.

Thus, in order to restrict the set of solutions for these differential equations, we also need more information. Unlike the circuits in EECS16A, however, we cannot arbitrarily choose this free variable. Instead, it must be set to reflect the actual behavior of our circuit. Consequently, we can appropriately set this free variable using the actual value of the function at a specific time, which can be derived from the behavior of our circuit in the specific problem context.

Here, let $x(0) = c_0$. This information is called an "initial condition" and is usually specified as the value the function takes at time $t = 0$. Although the initial condition is often specified, other points and boundary conditions can be used as well; for example, we can also use steady state, i.e. $t \rightarrow 0\infty$, behavior to solve for the constants in question.⁵

Hence, our system is defined as follows:

$$\frac{d}{dt}x(t) = ax(t) \quad (21)$$

$$x(0) = c_0 \quad (22)$$

Revisiting the solution to the differential equation above with the initial condition we get:

$$x(t) = ke^{at} \quad (23)$$

$$x(0) = ke^0 \quad (24)$$

$$x(0) = k = c_0 \quad (25)$$

Thus, we get the solution $x(t) = c_0e^{at}$. In the case of the discharging capacitor circuit, we set the initial condition $x(0) = V_{DD}$, where the capacitor was initially charged to V_{DD} . In this case solving for the constant multiplier gives us $k = V_{DD}$, yielding the solution $x(t) = V_{DD}e^{-\frac{t}{RC}}$. Finally, we have a specific solution to our problem.

4.3 Proof of uniqueness

Though we have one solution that satisfies the homogeneous differential equation and initial condition, we are not yet done. We need to ensure that we have not left out any solutions. To do so, we will prove that the solution we found is unique (Note: not all differential equations have unique solutions but we can prove the differential equation in this case does).

We start by assuming that there is another solution to the homogeneous differential equation. To argue for uniqueness we must show that the other solutions must be exactly the same as the solution that we have already found. Normally our first approach when proving equality is to manipulate both solutions to the same form, however, since we lack an expression for this hypothetical other solution, we must take another approach. We can show equality through one of two ways:

- The difference between the solutions is 0 everywhere the solution is defined.
- The ratio of the solutions is always 1.

⁵One question that may arise is whether it is valid to use times before $t = 0$ in order to compute the constant for the unique solution. Though we are free to use steady state behavior, the time in the problems we establish starts at time 0. Thus in the world of our problem there is no time before 0 and so it is invalid to consider times $t < 0$ to solve for unique solutions.

Showing either of the two statements will establish the equality between the two solutions, and hence prove the uniqueness of our original solution.

Proof:

We will prove equality with the second approach⁶. We have shown one solution: $x(t) = c_0 e^{at}$. Let us assume there is another solution to the homogeneous differential equation: $y(t)$ such that $\frac{d}{dt}y(t) = ay(t)$.

We want to show that the ratio $\frac{y(t)}{c_0 e^{at}} = 1$ everywhere. Here, the constant c_0 in the denominator can be a bit tricky to handle since it might be 0. So let us instead consider the ratio $\frac{y(t)}{e^{at}}$. Here, we are safe in knowing that the denominator is not zero.

Now we analyze the derivative of this ratio:

$$\frac{d}{dt} \frac{y(t)}{e^{at}} = \frac{d}{dt} y(t) e^{-at} = -ay(t) e^{-at} + e^{-at} \frac{d}{dt} y(t) = -aye^{-at} + aye^{-at} = 0.$$

The derivative of the ratio is always zero. This means that the ratio must be a constant. But which constant? For this, we can look at the initial conditions. From the initial conditions, we already know that $y(0) = c_0$ and $e^0 = 1$. So, the constant is just c_0 . In other words, the ratio $\frac{y(t)}{e^{at}} = c_0$ always, and so $y(t) = c_0 e^{at}$ always as well.

It is important to remember that this uniqueness proof is actually crucial. This is what allows us to use guess-and-check to solve differential equations with any confidence in the answer. Since essentially all so-called-methods for solving differential equations are really just ways of guessing, uniqueness is vital to being able to make progress.

4.4 Nonhomogeneous differential equations

Now that we have learned to solve homogenous differential equations (those for which the all zero solution is a potential solution), let us learn to solve nonhomogeneous differential equations where "all zero" is not a possible solution. These are differential equations of the form shown below. The motivating example we use here is a charging capacitor in an RC circuit. This is akin to an inverter switching from '0' to '1'.

$$\frac{dx}{dt} = ax + b, \text{ where } b \neq 0 \quad (26)$$

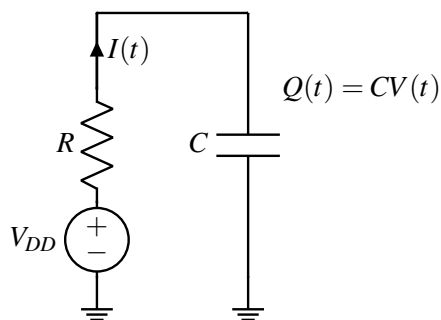

Figure 16: Capacitor charging through resistor circuit

⁶In general when faced with multiple approaches to solve a problem it is advantageous to try them all. As you attempt the problem, some approaches will inevitably appear easier. You can follow through with these approaches to arrive at a solution!

In general when solving unknown problems we want to try to reformulate them in terms of problems we know how to solve. So we formulate the above as a homogeneous differential equation that we know how to solve, and we want to do so in a way that doesn't make any assumptions.

In terms of circuits these homogeneous equations corresponded to our circuit having steady state values of 0. Here, however, the steady state value converges to some constant instead. To force this into a homogeneous differential equation we need to change variables so as to add an offset to shift the steady state value of our circuit to 0. We can accomplish this mathematically by substituting $\tilde{x}(t) = x(t) + \frac{b}{a}$ or $x(t) = \tilde{x}(t) - \frac{b}{a}$. This is simply a change of variables. We have represented our variable in a more convenient form without making any assumptions and changing the initial problem statement!⁷ With this substitution we get:

$$\frac{d}{dt}\tilde{x}(t) = a\tilde{x}(t) \quad (27)$$

This is exactly the homogeneous case we learned to solve before! Using the techniques described in the previous section we can find that $\tilde{x}(t) = ke^{at}$. We can now re-substitute to get $x(t) = ke^{at} - \frac{b}{a}$. As before we need an initial condition to solve for the constant k. Let the initial condition be $x(0) = c_0$. Plugging this in, we get:

$$c_0 = ke^0 - \frac{b}{a} \quad (28)$$

$$k = c_0 + \frac{b}{a} \quad (29)$$

$$x(t) = \left(c_0 + \frac{b}{a}\right)e^{at} - \frac{b}{a} \quad (30)$$

To check this let us plug our solution back into the original differential equation in Equation (26). Since we start with $x(t) = \left(c_0 + \frac{b}{a}\right)e^{at} - \frac{b}{a}$, we expect:

$$\text{LHS: } \frac{d}{dt}x(t) = \frac{d}{dt}\left(\left(c_0 + \frac{b}{a}\right)e^{at} - \frac{b}{a}\right) = a\left(c_0 + \frac{b}{a}\right)e^{at} - 0 = a\left(c_0 + \frac{b}{a}\right)e^{at} \quad (31)$$

$$\text{RHS: } a\left(\left(c_0 + \frac{b}{a}\right)e^{at} - \frac{b}{a}\right) + b = a\left(c_0 + \frac{b}{a}\right)e^{at} - b + b = a\left(c_0 + \frac{b}{a}\right)e^{at} \quad (32)$$

Hence, LHS = RHS, and $\frac{d}{dt}x(t) = ax(t) + b$ is solved by $x(t) = \left(c_0 + \frac{b}{a}\right)e^{at} - \frac{b}{a}$. In fact it can be shown that it is uniquely⁸ solved by $x(t) = \left(c_0 + \frac{b}{a}\right)e^{at} - \frac{b}{a}$.

With these techniques, let us go back and approach the motivating example of a charging capacitor circuit. In the above circuit we know that $I = C\frac{d}{dt}V(t)$ and that $V_{DD} - V(t) = I(t)R$ by Kirchoff's law. Combining these equations together we get that $-RC\frac{d}{dt}V(t) = V(t) - V_{DD}$. Rewriting this as $\frac{d}{dt}V(t) = \frac{-V(t)}{RC} + \frac{V_{DD}}{RC}$ we get a nonhomogeneous differential equation as we discussed above where $a = -\frac{1}{RC}$ and $b = \frac{V_{DD}}{RC}$.

As in the generalized example, we perform a substitution: $V(t) = \tilde{V}(t) + V_{DD}$. Substituting this back in, we get:

$$\frac{d}{dt}(\tilde{V}(t) + V_{DD}) = \frac{-(\tilde{V}(t) + V_{DD})}{RC} + \frac{V_{DD}}{RC} \quad (33)$$

⁷For example when solving $x + 2 = 7$ We can represent x as $x = \tilde{x} + 2$ or $x = \tilde{x} + 5$ if that makes the problem more convenient. With $x = \tilde{x} + 5$ we get $(\tilde{x} + 5) + 2 = 7$ Which we can solve to get $\tilde{x} = 0$ and $x = 5$. The initial problem is unchanged as x was simply a variable that we chose to represent in a more convenient manner \tilde{x} .

⁸We already proved uniqueness in the homogeneous case. This is in fact sufficient to prove uniqueness in the nonhomogeneous case, as we can simply do a change of variables to phrase our problem as a homogeneous differential equation and prove uniqueness for this reformatted problem.

Since V_{DD} is a constant, $\frac{d}{dt}V_{DD} = 0$. This gives us:

$$\frac{d}{dt}\tilde{V}(t) = -\frac{\tilde{V}(t)}{RC} \quad (34)$$

We can solve this homogeneous differential equation to get $\tilde{V}(t) = ke^{\frac{-t}{RC}}$. To solve for the value of k we resubstitute and use our initial condition: $V(0) = 0$.

$$V(t) = \tilde{V}(t) + V_{DD} \quad (35)$$

$$V(t) = ke^{\frac{-t}{RC}} + V_{DD} \quad (36)$$

$$0 = ke^0 + V_{DD} \quad (37)$$

$$\therefore k = -V_{DD} \quad (38)$$

With this, we find that the solution to our differential equation is

$$V(t) = V_{DD}(1 - e^{\frac{-t}{RC}}) \quad (39)$$

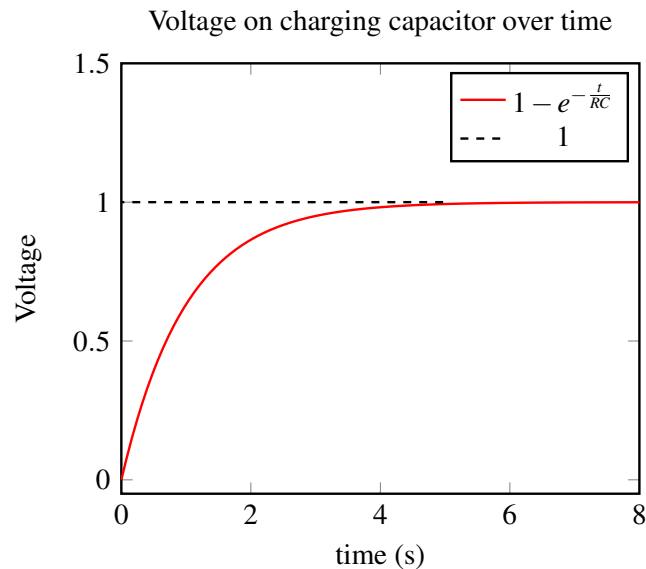

Figure 17

5 Nonlinear differential equations

In the above sections we only talked about linear differential equations where $\frac{d}{dt}x(t) = ax(t) + b$. However, in general you may encounter differential equations like $\frac{d}{dt}x(t) = x(t)^2$ and other such nonlinear functions of $x(t)$.

In general, there are various "techniques" that can be used to attempt to guess potential solutions for such equations. At the end of the day, all of these guesses need to be checked and the appropriate uniqueness theorems proved to make sure that we have got the single true solution. Only then can this solution be used for any predictive purposes.

Without a uniqueness theorem, such solutions cannot be trusted for prediction. In the homework, you will see an example that illustrates how a seemingly innocuous differential equation can have non-unique solutions. In that homework, we will also share another heuristic technique that can be used to guess solutions to nonlinear differential equations — a technique known as "separation of variables." There are many such heuristic techniques out there, and different ones tend to work for different types of equations. You will encounter these techniques in later courses alongside the kinds of differential equations for which they tend to work.

Contributors:

- Neelesh Ramachandran.
- Nikhil Shinde.
- Anant Sahai.
- Aditya Arun.